



Loss Prevention • *Guide*

NORTH 
SERVICE, STRENGTH, QUALITY

STEEL PRESHIPMENT SURVEYS
A GUIDE TO GOOD PRACTICE
Second Edition

Arthur Sparks and The North of England P&I Association

GUIDE TO USING ELECTRONIC VERSION

1. All book sections, headings and subheadings appear as bookmarks in the left-hand navigation pane. Use this as your primary navigation.
2. Use the reader search window to search for a specific word or phrase in the text.
3. All text which refers to another part of the book is linked to the relevant page, indicated by cursor changes. Click to go there, and use the previous view button in your reader or browser to go back.
4. Some words or phrases are linked to further information in other parts of the book, indicated by cursor changes. Click to go there, and use your previous view button to go back.
5. Names of organisations and publications may include links to their websites, indicated by cursor changes. Click to go to the website via your browser.

TERMS OF USE

This publication may be used solely by the Authorised User. The Authorised User shall comprise any company or individual (or employees thereof) to which The North of England P&I Association has granted permission to use this publication. Any other unauthorised manner of exhibition, broadcast or distribution of the information, form, content or presentation contained herein and any public performance, diffusion, editing, copying, reselling, hiring in whole or in part, is prohibited.

First edition published in 1993 by Anchorage Press
ISBN 0 9516627 3 2

Reprinted in 2005 by The North of England P&I Association Limited
ISBN 0 9546537 7 7

Second edition published in 2010
by The North of England P&I Association Limited
The Quayside, Newcastle upon Tyne, NE1 3DU, United Kingdom

Reprinted in 2015

Telephone: +44 191 232 5221
Fax: +44 191 261 0540
Email: loss.prevention@nepia.com
Website: www.nepia.com

All rights reserved. No part of this publication may be reproduced, stored in a retrieval system or transmitted in any form or by any means (electronic, mechanical, photocopying, recording or otherwise) without the written permission of the publisher.

Copyright © The North of England P&I Association Limited 2010

ISBN 978-0-9558257-3-6

Authors: Arthur Sparks and The North of England P&I Association

Printed and bound in the UK

Whilst care is taken to ensure the accuracy of any information made available (whether orally or in writing and whether in the nature of guidance, advice, or direction) no warranty of accuracy is given and users of the information contained herein are expected to satisfy themselves that it is relevant and suitable for the purposes to which it is applied or intended to be applied. No responsibility is accepted by the author, North or by any person, firm, corporation or organisation who or which has been in any way concerned with the furnishing of data, the development, compilation or publication thereof, for the accuracy of any information or advice given herein or for any omission herefrom, or for any consequences whatsoever resulting directly or indirectly from, reliance upon or adoption of guidance contained herein.

CONTENTS

<i>Chapter</i>	<i>Page</i>
1. INTRODUCTION	3
The need for pre-shipment surveys	3
Problems with implementation	3
The purpose of this guide	3
2. APPOINTING A SURVEYOR	5
Allowing sufficient time	5
Give clear terms of reference	5
3. DESCRIBING SURFACE CONDITION OF STEEL CARGO	7
Surface-condition clauses	7
Examples of applying surface-condition clauses	8
4. DESCRIBING MECHANICAL DAMAGE TO STEEL CARGO	15
Mechanical-damage clauses	15
Examples of applying mechanical-damage clauses	16
5. INSPECTING WEATHER-DECK OPENINGS	20
Allow time for proper repairs	20
Check all components of all openings	20
Carry out weathertightness tests	21
APPENDICES	24
I Checklist for steel cargo survey report	24
II Checklist for weather-deck openings survey report	26
III P&I clubs circular 28 February 1964	28
INDEX	29

GUIDE TO USING ELECTRONIC VERSION

1. All book sections, headings and subheadings appear as bookmarks in the left-hand navigation pane. Use this as your primary navigation.
2. Use the reader search window to search for a specific word or phrase in the text.
3. All text which refers to another part of the book is linked to the relevant page, indicated by cursor changes. Click to go there, and use the previous view button in your reader or browser to go back.
4. Some words or phrases are linked to further information in other parts of the book, indicated by cursor changes. Click to go there, and use your previous view button to go back.
5. Names of organisations and publications may include links to their websites, indicated by cursor changes. Click to go to the website via your browser.

TERMS OF USE

This publication may be used solely by the Authorised User. The Authorised User shall comprise any company or individual (or employees thereof) to which North of England P&I Association has granted permission to use this publication. Any other unauthorised manner of exhibition, broadcast or distribution of the information, form, content or presentation contained herein and any public performance, diffusion, editing, copying, reselling, hiring in whole or in part, is prohibited.

Chapter 1

INTRODUCTION

THE NEED FOR PRE-SHIPMENT SURVEYS

Most steel products rust and bend easily, particularly when carried at sea. Shipowners and operators – and ultimately their P&I insurers – are therefore usually first in the firing line when bent and rusty steel arrives at its destination.

As a result, shipowners, carriers, operators and P&I clubs now regularly commission independent pre-shipment surveys of steel cargoes to ensure that bills of lading and / or mate's receipts accurately describe the apparent order and condition of the cargo when it was taken on board the ship. As a further precaution against rust claims, surveyors are also generally now asked to look at the weathertightness and ventilation of the holds in which steel cargo is carried.

However, rust is a long and gradual process of surface oxidation which may start as soon as a piece of steel is produced and end with its total structural degradation. Simply describing steel cargo as 'rusty' when shipped is thus of little help in defending a claim for severe corrosion. Conversely, shippers invariably refuse to accept that recently manufactured steel with traces of oxidation should be described as 'rusty'.

To help matters the principal P&I clubs put out a circular on 28 February 1964 specifying 27 clauses which could be used to describe the degree of rust on steel cargo or its steel packing (see Appendix III). Ranging from 'partly rust stained' to 'rust with pitting', these are in use throughout the international shipping community.

PROBLEMS WITH IMPLEMENTATION

Unfortunately, the P&I club clauses are still not accepted as an international standard. The world's shipping community is not obliged to use the clauses – they are simply 'permissible' in 'appropriate cases'. Furthermore, despite the applicability of the P&I club clauses to a broad range of rust conditions, the brevity of the clauses means they are still at risk of being misinterpreted. For example, there is little to distinguish 'rust stained' from 'rusty'.

Carriers are therefore at a disadvantage when attempting to establish standard usage of the clauses – particularly when they are under pressure from exporters and importers to modify application of the clauses to suit their respective commercial positions.

THE PURPOSE OF THIS GUIDE

The primary objective in producing this guide is to ensure correct and consistent usage of the P&I club clauses, thus enfranchising them with the status of an international standard method for describing steel cargoes.

In addition to 18 surface-condition clauses a further 16 mechanical-damage clauses are recommended. Together they provide sufficient flexibility to cover the entire spectrum of damage and defects which are likely to be encountered in pre-shipment survey work. With

each clause a short, simple description is provided which more fully describes the condition to which the clause should apply. To ensure universal understanding, photographs are included to illustrate the application of the clauses with various types of cargo.

Guidance is also provided on the conduct of weather-deck opening surveys, which should form an integral part of every prudent pre-shipment survey. This includes details of the items which should be checked and a review of the advantages and disadvantages of the main types of weathertightness test.

Checklists are included in Appendices I and II to show the extent of information which should be provided in reports. This is as much to foster a consistent and professional approach among the international surveying community – which is increasingly exposed to negligence claims – as it is to eliminate misunderstandings between the world's ports with regard to the clausing of shipping documents.

And, because surveyors are still told too little too late, a recommended procedure is set out for appointing and commissioning surveyors for this important role in international trade.

Chapter 2

APPOINTING A SURVEYOR

ALLOW SUFFICIENT TIME

A surveyor must be provided with sufficient time to undertake a survey – certainly no less than a full working day before the ship commences loading.

Several hours writing time can be required to prepare the lists necessary to identify the various parcels of cargo – which may be on the open quayside, in closed warehouses, in rail wagons in sidings or on coasters yet to arrive. It is also important for the surveyor to be aware of how and when the cargo will be loaded.

Surveyors appointed with insufficient time should immediately inform their principals when it transpires that they have been appointed too late to execute a proper survey and propose two courses of action

- abandon the survey
- commence the survey at a certain stage in the loading operations so that it only takes in a part of the cargo.

GIVE CLEAR TERMS OF REFERENCE

Surveyors should be provided with written terms of reference as soon as possible after their appointment which state clearly what is expected of them. The following is recommended as the *minimum* information which should be provided.

Surveyor's terms of reference	
1.	Name of the ship concerned.
2.	Date and time the ship is scheduled to arrive at the port of loading.
3.	Date and time that loading is scheduled to commence.
4.	Location of the loading berth.
5.	Name of the carrier's agent in the port of loading.
6.	Name of the principal (e.g. shipowner / charterer).
7.	Confirmation of subject(s) to be surveyed (e.g. all steel cargo / specific parcel(s) of steel cargo / all weather-deck openings).

8. Description of the work to be undertaken. This should always include the following paragraphs.
 - (a) Ensuring that descriptive clauses and their application are made available to the tally-clerk before loading.
 - (b) Inspection / testing of agreed items as required to enable completion of a survey report in accordance with the attached checklist (see Appendices I and II).
 - (c) Assisting the master by ensuring that the approved clauses are accurately superimposed on the bills of lading and / or mate's receipts and / or exception lists.
 - (d) Submission of the completed survey report to the principal in time for it to be forwarded to the port of discharge before the vessel arrives.
 - (e) Monitoring the loading and stowage operation and advising the master immediately if any aspect of the loading and stowage might damage the cargo (e.g. loading during rain, mixing wet and dry cargoes in the same hold, incorrect or inappropriate stowage, inadequate lashing or securing).
 - (f) Additional inspection of cargo, vessel, loading operations or stowage to be undertaken as required by the master or as deemed prudent by the surveyor, subject to principal's approval (e.g. additional parcels of cargo, cleanliness of holds, standards of lashing and securing being achieved).

Chapter 3

DESCRIBING SURFACE CONDITION OF STEEL CARGO

SURFACE-CONDITION CLAUSES

Clauses used to describe the surface condition of steel cargo – or its steel packing – must accurately describe the apparent order and condition of the visible surfaces at the time of shipment. In cases where it is suspected that the cargo has already been in contact with salt water or other chlorides, this should be confirmed by silver nitrate testing.

The following is a list of recommended clauses, the majority of which were specified in the P&I clubs' circular of 28 February 1964 (see Appendix III). To ensure consistency in interpretation, a more detailed description of the surface condition to which each clause should apply is also shown here. Clauses should only be used in English.

All clauses can be used in combination with other surface-condition and mechanical-damage clauses as appropriate. Italics indicate that additional wording is necessary.

Surface-condition clauses	
1.	Covered with snow Surface covered with snow or ice or both.
2.	Galvanising affected by white oxidation marks Zinc coating losing lustre and etched with white-coloured oxidation marks.
3.	Galvanising affected by white rust Zinc coating heavily oxidated and covered in voluminous white coloured rust.
4.	Galvanising dull Zinc coating losing lustre as a result of early oxidation.
5.	Grease spots and oil patches apparent on <i>number units</i> Surface stained with drops of grease and oil from mechanical handling equipment or other sources.
6.	Partly rust stained Fine powdery rust covering less than 75 % of the surface. Light tan to light brown in colour and easily removed by rubbing, scraping or wire brushing to reveal a smooth steel surface. The remainder of the surface may still have mill scale attached.
7.	Partly rusty Brown to heavy deep brown rust covering less than 75 % of the surface. Slightly uneven and dull steel surface revealed when removed by wire brushing. Remainder of the surface may be 'rust stained' or 'partly rust stained'.

8. Rust on edges	Brown to heavy deep brown rust confined to edges. When removed by wire brushing, a slightly uneven and dull steel surface revealed. Remainder of the surface may be 'rust stained' or 'partly rust stained'.
9. Rust spots apparent	Localised very slight penetration of rust through mill scale, not bulbous and reveals smooth steel surface when removed by wire brushing. Parts of surface without mill scale may be 'rust stained'.
10. Rust spotting	Localised penetration of rust through mill scale, bulbous and reveals an uneven steel surface when removed by wire brushing. Parts of surface without mill scale may be 'rust stained'.
11. Rust stained	Fine powdery rust over the whole surface, light tan to light brown in colour and easily removed by rubbing, scraping or wire brushing to reveal a smooth steel surface.
12. Rust with pitting	Brown to heavy deep brown rust which, when removed by wire brushing, reveals pitting of the steel surface.
13. Rusty	Brown to heavy deep brown rust which, when removed by wire brushing, reveals an uneven and dull steel surface.
14. Stained extent by an unidentifiable colour powder	Surface coated to the extent indicated with an unidentifiable powder of the colour indicated which could contain aggressive chemicals or be capable of holding moisture.
15. Streaky rust indicates previous contact with water	Surface has rust streaks indicating that water has previously dripped down it.
16. Surface areas reacting to silver nitrate solution tests	Silver nitrate tests prove that the surface has been in contact with salt water or other chlorides.
17. Wet before shipment	Water visible on surface or dripping out of bundles.
18. Packing + surface-condition clause	The surface condition of the cargo packing is as described by any of the above clauses.

EXAMPLES OF APPLYING SURFACE-CONDITION CLAUSES

The following photographs of various types of steel cargoes illustrate how the surface-condition clauses should be applied in practice (Figs 1–17).



Fig. 1. Channels and angles (rust cleaned away locally). Surface-condition clause: **rust stained**

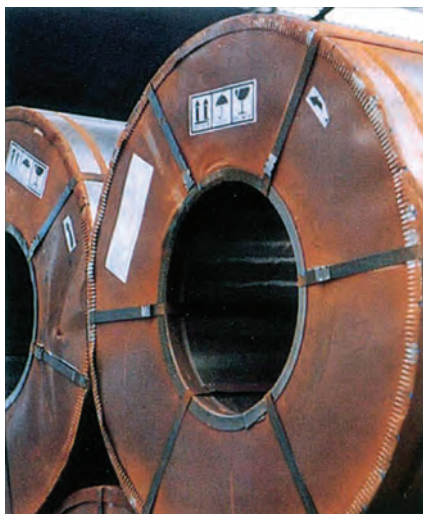

Fig. 2. Wrapped coils. Surface-condition clause: **packing rust stained**

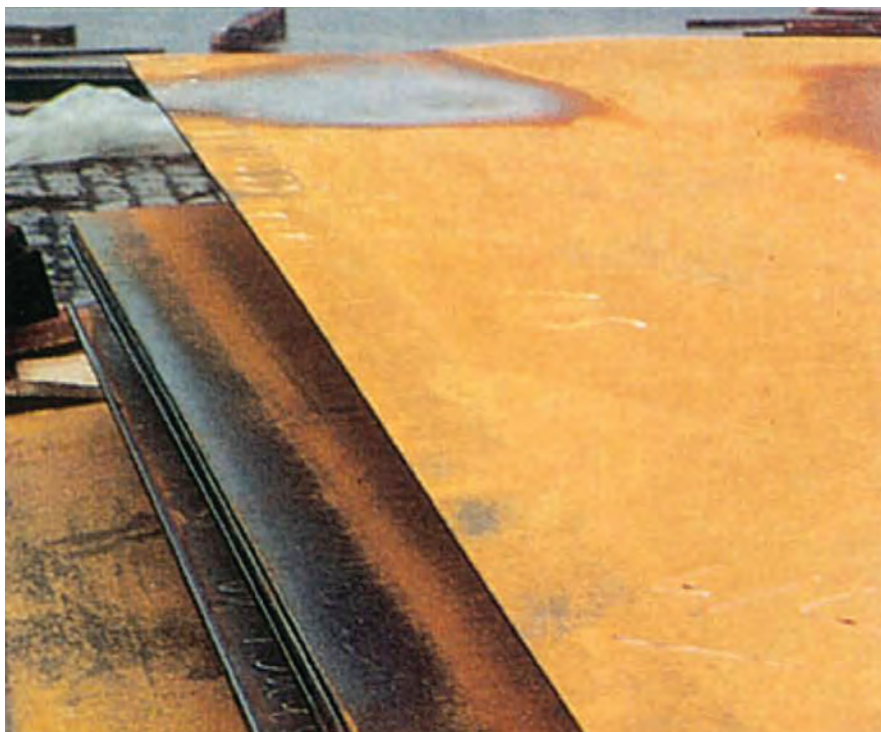

Fig. 3. Steel plates. Surface-condition clause: **rust stained, wet before shipment**



*Fig. 4. Reinforcing bars in bundles with dampness evident. Surface-condition clause: **rust stained, wet before shipment***



*Fig. 5. Plates with most mill scale intact, but handling has also fragmented mill scale from edges. Surface-condition clause: **partly rust stained, wet before shipment***



*Fig. 6. Beams with some mill scale still intact but rust encroaching on flanges and webs. Note correct nesting position. Surface-condition clause: **rust stained***



Fig. 7. Wrapped packages of steel plates. Surface-condition clause: **packing partly rust stained**



Fig. 8. Hot-rolled steel coils. Surface-condition clause: **rusty**



Fig. 9. Channels. Surface-condition clause: **rusty**



Fig. 10. Plates. Surface-condition clause: **rust with pitting**



*Fig. 11. Hot-rolled steel coil. Surface-condition clause: **rust stained, rust spots apparent***



*Fig. 12. Rails. Surface-condition clause: **rust with pitting***

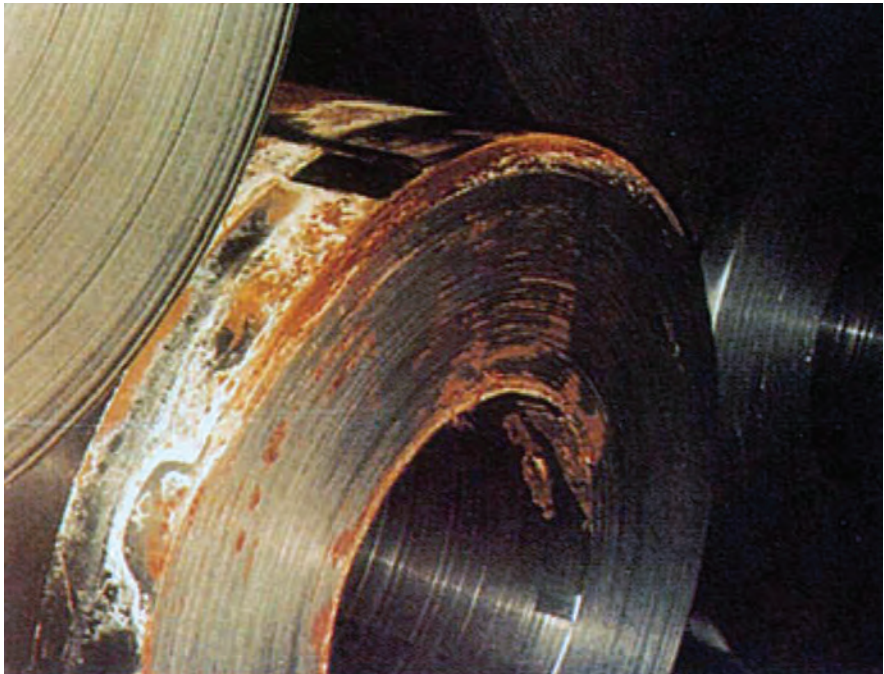

*Fig. 13. Galvanised coils (with wrappers removed). Surface-condition clause: **galvanising affected by white rust***



Fig. 14. Wrapped coil with streaky rust brought about by dripping water from 'cargo sweat'. Surface-condition clause: **packing rust stained, streaky rust indicates previous contact with water**



Fig. 15. Galvanised pipes bundles showing no evidence of having been subjected to a passivation process. Surface-condition clause: **galvanising dull**



Fig. 16. Beams with flaking mill scale on webs. Surface-condition clause: **rust stained, rust spots apparent**

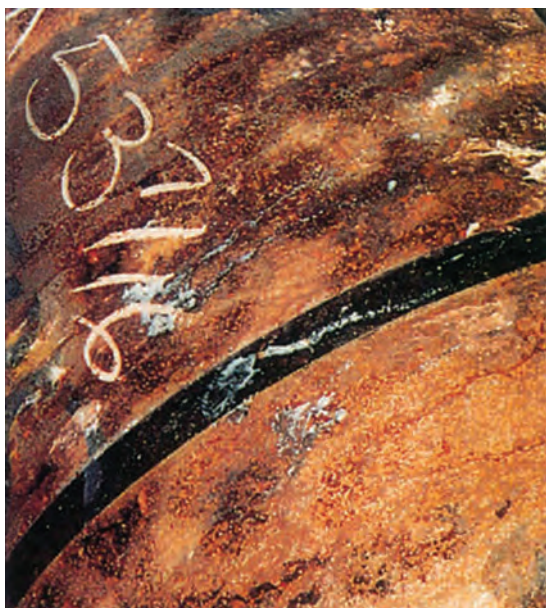

Fig. 17, Hot-rolled coil which has been in contact with salt water, suspect indications being configuration and colour of the rust. Surface-condition clause: [rust clause applicable] + **surface areas reacting to silver nitrate solution tests**

Chapter 4

DESCRIBING MECHANICAL DAMAGE OF STEEL CARGO

MECHANICAL-DAMAGE CLAUSES

Clauses used to describe any mechanical damage to steel cargo must accurately describe the apparent order and condition of the cargo or defects to its steel packing at the time of shipment.

The following is a list of recommended clauses together with more detailed descriptions of the mechanical damage and types of cargo to which each clause should apply. Clauses should only be used in English.

All clauses can be used in combination with other mechanical-damage or surface-condition clauses as appropriate. One or more of the words shown in brackets should be used as appropriate. Italics indicate that additional wording is necessary.

Mechanical-damage clauses	
1.	Bent, flanges and webs distorted. A previously straight structural section has been bent causing both flanges and webs to be distorted.
2.	Bundle pieces bent along entire length. Affects <i>number</i> pieces. A number of previously straight plates, rods, pipes or other small scantling pieces in a bundle are bent along their entire length.
3.	Bundle pieces projecting on ends – <i>number</i> pieces bent. Some plates, rods, pipes or other small scantling pieces in a bundle are projecting beyond most others resulting in bent ends for a certain number.
4.	Concrete coating (hairline cracked / chipped / broken) at <i>location</i>. The concrete weight coating on a pipe has hairline cracks or is chipped or broken at a particular location.
5.	Dented in <i>number</i> positions at <i>location</i>. A pipe or other hollow section is dented in a number of positions at a particular location causing a reduction in internal dimensions.
6.	Edges (dented / buckled) at <i>location</i> where handling gear marked. Affects <i>number</i> (windings / plates). The edges of a hot-rolled steel sheeting coil or plate bundle at a particular location have been dented or buckled over a number of windings or plates by handling equipment.
7.	Edges (scored / gouged) at <i>location</i>. Affects <i>number</i> (windings / plates). The edges of a hot-rolled steel sheeting coil or plate bundle at a particular location are deeply scored over a number of windings or plates.
8.	Edges (waved / distorted / bent upwards) at <i>location</i>. The edges of a steel plate are waved, distorted or bent upwards at a particular location.
9.	Flange bent in <i>number</i> positions at <i>location</i>. The flange of a structural section is bent in a number of positions at a particular location.

<p>10. Interlocking grooves (bent / dented) in number positions at location. The interlocking grooves of a sheet pile are bent or dented in a number of positions at a particular location.</p>
<p>11. Machined surfaces (scored / nicked / indented) to a depth in excess of number mm. The smooth machined surface – such as bevelled ends or flanges of a pipe – is scored, nicked or indented in excess of a certain depth in millimetres.</p>
<p>12. Packing (torn open / punctured) in number positions at location. Visible cargo is surface-condition and / or mechanical-damage clauses. Packing is torn open or punctured in a number of positions at a particular location to reveal the surface condition of and / or mechanical damage to the cargo underneath.</p>
<p>13. Packing edges at location dented where handling gear marked. Packing edges at a particular location have been dented by handling equipment.</p>
<p>14. Protective coating (chafed / scored / broken / missing) at location. The epoxy, bituminous, coal-tar, asphalt mastic or other protective coating on a pipe, sheet pile or other product is chafed, scored, broken or missing at a particular location.</p>
<p>15. Strapped insufficiently, number strapping bands (loose / broken / missing). A hot-rolled steel sheeting coil or a bundle of plates, rods, pipes or other small scantling pieces is insufficiently bound due to a number of loose, broken or clearly missing strapping bands.</p>
<p>16. Windings at location telescoped up to number mm. The windings of a steel sheeting coil have moved in the direction of the coil axis up to a certain number of millimetres.</p>

EXAMPLES OF APPLYING MECHANICAL-DAMAGE CLAUSES

The following photographs of various types of steel cargoes illustrate how the mechanical-damage clauses should be applied in practice (Figs 18 - 26).



*Fig. 18. Wrapped coil damaged by forklift. Mechanical-damage clause: **packing torn open in one place at inner circumference. Visible cargo is scored. Affects 15 windings***

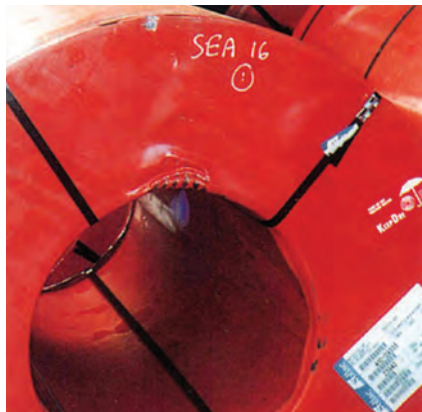

*Fig. 19. Wrapped coil damaged by lifting clamp. Mechanical-damage clause: **packing edges at inner circumference dented where handling gear marked***

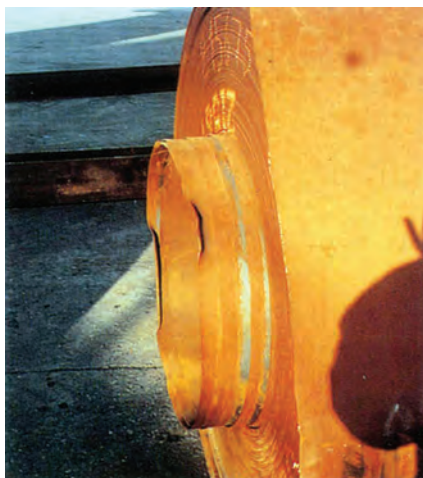

Fig. 20. Telescoped coil. Mechanical-damage clause: windings at core telescoped up to 150 mm



Fig. 21. Coil damaged by forklift. Mechanical-damage clause: edges buckled at outer circumference where handling gear marked. Affects six windings



Fig. 22. Plates. Mechanical-damage clause (top plate in stack): edges waved along entire length



*Fig. 23. Bundles of light scantling pieces. Mechanical-damage clause (second bundle from left): **bundle pieces bent along entire length. Affects two pieces. Strapped insufficiently, one strap broken, three missing***



*Fig. 24. (below) Nest of beams. Mechanical-damage clause (left hand beam): **flange bent in one position at end***



*Fig. 25. (above) Bundle of stainless steel plates. Mechanical-damage clause: **edges dented at centre where handling gear marked. Affects two plates***



*Fig. 26. Bundle of angles overlying bundle of plates. Mechanical-damage clause (angles): **edges dented at bottom centre where handling gear marked. Affects two pieces. Strapped insufficiently, one strapping band broken***

Chapter 5

INSPECTION OF WEATHER-DECK OPENINGS

ALLOW TIME FOR PROPER REPAIRS

The primary objective of inspecting a vessel's weather-deck openings and associated closing appliances is to ensure that they are in good condition, weathertight and fully effective in their contribution to the vessel's seaworthiness *before* the vessel puts to sea. There is little to be gained if faults discovered during the survey are not reported until after the voyage has begun and cannot be properly repaired.

Surveyors should therefore aim to complete an initial inspection as *soon as they can board the vessel* and to submit their findings to the master and principal without delay. This should enable permanent repairs to be undertaken – if necessary by specialist shore-based contractors – before the surveyors' final inspection and report (see Appendix II for checklist).

If permanent repair of a particular opening proves to be impractical, surveyors can accept a temporary repair if they consider it will remain effective for the *entire duration of the voyage* bearing in mind the weather conditions likely to be encountered. The use of tarpaulins over hatches, masking or marine tape over joints, or timber packing under existing seals should *not* be accepted as adequate temporary repairs (though marine tape can be used as added protection on hatches already tested as being weathertight).

CHECK ALL COMPONENTS OF ALL OPENINGS

A survey of weather-deck openings should entail detailed examination of all deck openings and all components of those openings.

Deck openings include cargo hatches, ventilators, sounding pipes, access openings and any other weather-deck aperture through which rain or sea water might pass (see Figs 27–31). The components of deck openings include the steelwork which forms the openings, the closing appliance (hatch cover, door, cap, etc), the flexible material (usually rubber) which seals the openings against water ingress and the mechanical securing system which fixes the closing appliances in position when at sea (cross-wedges, cleats, pins, screw threads, etc).

Any signs of leakage – particularly internal rust staining – should be thoroughly investigated and all defects reported.

Condition of openings

Compression bars and coamings should be clean, free of corrosion, straight and structurally sound. All gutterways and drain holes must be clear and drain-hole non-return valves should function. No rust staining should be visible on the inside of openings.

Condition of closing appliances

Hatch closing appliances should not be perforated or structurally weakened by rust and their compression bars should be clean, free of corrosion, straight and structurally sound. Leading and trailing edges of adjacent hatch panels should be level with each other in the

closed position, and wheels on hatch panels should be well greased and easily rotated by hand when the panels are lifted.

Condition of flexible joints

Rubber joints should be pliable and in good condition. Other than a small central depression mark (the depth of which should be reported) they should not be deformed or damaged in any other way.

Condition of securing system

Securing systems must be strong and tight enough to prevent closing appliances moving in heavy seas but should only require minimal force to apply. Cross-wedges should be straight and easily hit home with a hand hammer. Bars forming quick-release cleats should be straight and not excessively corroded. Associated adjustment nuts should not be seized and rubber washers must be pliable and in good order.

CARRY OUT WEATHERTIGHTNESS TESTS

The survey should also include an ultrasound or hose test of every opening in a closed condition in order to test for weathertightness. In the case of hatch covers or other closing appliances which limit pressure on sealing joints by direct steel-to-steel contact (see Fig. 32), no attempt should be made during weathertightness testing to increase pressure on the joint by excessive tightening of the mechanical securing system. This could result in distortion of the panels leading to impairment of weathertight integrity once the vessel starts to work in a seaway.

Ultrasonic testing

An ultrasound transmitter is placed in the hold while a hand-held detector on the weather deck is moved around the joint areas of closed openings. The strength of the received signal, measured in decibels, determines whether or not the joint is weathertight.

Advantages: Can be used at any stage of loading, gives an accurate indication of weathertightness, gives an accurate indication of potential areas of leakage, can be used in sub-zero temperatures, can be used in wet weather, and can be used by one surveyor.

Disadvantages: Equipment may be expensive and proper training of users is required.

Hose testing

This involves applying a high pressure jet of water directly onto the joints of closed openings from the weather deck and observing any leakage from within the cargo hold. Lloyd's Rules specify that the pressure of the water jet should be at least 0.2 N/mm^2 and that the hose should be no more than 1.5 m from the joint under test. In the case of recessed joints which cannot be jetted directly, it is recommended that the recess drain holes at the ends of transverse gutterings be temporarily plugged during testing to allow a head of water to build up over the joints.

Advantages: Inexpensive, gives an indication of weathertightness, can be used in wet weather, and widely accepted.

Disadvantages: Cannot be used with cargo on board, cannot be used in sub-zero temperatures, two surveyors necessary (one to inspect jetting, one to observe leakage), and additional equipment and assistance required for jetting.



Fig. 27. Bilge sounding pipe surrounded by water. The pipe and its screw cap must be in good condition and the cap properly secured to ensure no water gets into the cargo hold below

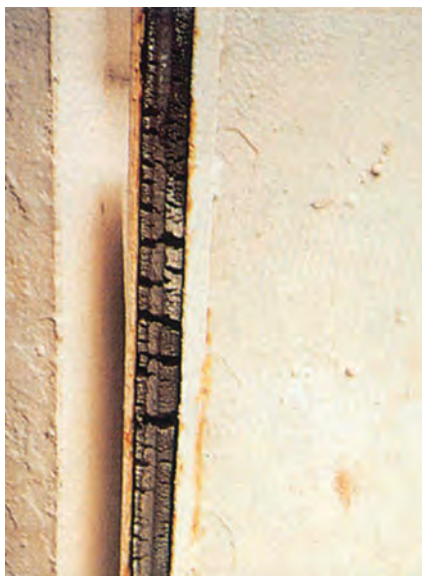

Fig. 28. Hatch cover rubber joint which is hardened and perished to the point where it can no longer provide a weathertight seal



Fig. 29. Mast house door leading to a cargo hold internal escape hatch. Closer examination reveals that the door's sealing rubber has been painted over and is hardened, excessively compressed and perished leaving the cargo vulnerable



Fig. 30. A goose-neck air pipe with a closing flap secured by a wing nut. However; the pipe has rusted through above the flap and is no longer weathertight



Fig. 31. Mushroom-headed natural-draft cargo-hold ventilator with handle-operated internal closing flap. The handle and flap should be checked and operated to ensure that full opening and closure is possible

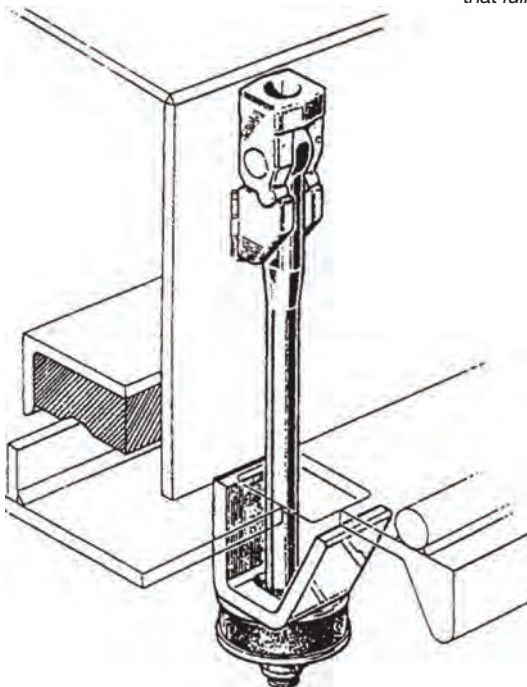

Fig. 32. Cut-away drawing of the side of a hatch cover secured to the cantilevered hatch coaming by a quick-release cleat with a rubber washer and adjusting nut. The steel-to-steel contact between the hatch and the coaming means that increasing the tightness of the cleat will not improve the hatch's weathertight integrity

Appendix I

CHECKLIST FOR STEEL CARGO SURVEY REPORT

SURVEY

- | | |
|-----|--|
| 1.1 | Name of surveyor(s) |
| 1.2 | Date of report |
| 1.3 | Name of person / organisation commissioning survey |
| 1.4 | Name of organisation survey commissioned for |
| 1.5 | Summary of surveyor's terms of reference |

VESSEL

- | | |
|------|--|
| 2.1 | Name |
| 2.2 | Type |
| 2.3 | Gross tonnage |
| 2.4 | Port of registry |
| 2.5 | Classification society |
| 2.6 | Date built |
| 2.7 | Place built |
| 2.8 | Details of safety construction certificate |
| 2.9 | Details of classification certificate |
| 2.10 | Details of last load line survey |
| 2.11 | Details of last special survey |
| 2.12 | Number of cargo holds |
| 2.13 | Number of deck hatches per hold |
| 2.14 | Hatch closing system |
| 2.15 | Number of deck ventilators per hold |
| 2.16 | Ventilation system |
| 2.17 | Type of cargo carried on last voyage |
| 2.18 | Type of cargo carried on voyage before last voyage |

COMPANIES / PERSONNEL

- | | |
|-----|--|
| 3.1 | Name and address of owner |
| 3.2 | Name and address of manager / operator |
| 3.3 | Name and address of charterer |
| 3.4 | Name of charterer's agent at port of loading |
| 3.5 | Name of owner's agent / P&I correspondent at port of loading |
| 3.6 | Name of master |

3.7	Name of chief officer
3.8	Name of supercargo
3.9	Name of stevedoring company
3.10	Name of tallying company
3.11	Names and business of others in attendance

ACTIVITY REPORT

4.1	Location of loading berth
4.2	Time and date vessel arrived
4.3	Time and date surveyor proceeded on board
4.4	Time and date loading commenced
4.5	Time and date loading completed
4.6	Time and date vessel departed
4.7	Brief description steel cargo hold cleaning
4.8	Brief description of steel cargo loaded
4.9	Total weight of cargo loaded
4.10	Weight of steel cargo loaded per discharge port
4.11	Brief description of other cargo stowed in steel cargo holds and where stowed in relation to steel
4.12	Full details of disputes arising during loading concerning bills of lading (attach all relevant correspondence)
4.13	Full details of stevedore damages occurring during loading (attach all relevant correspondence)
4.14	Full details of weather conditions during loading and of stoppages and protective action taken during wet weather [#]
4.15	Full details of silver nitrate tests carried out and of any disputes arising
4.16	Full details of surveyor's involvement with clausing bills of lading / mate's receipts / exception lists*
4.17	State if surveyor present when bill of lading / mate's receipts / exception lists* signed

CARGO REPORT

5.1	Port of destination
5.2	Hold number(s)
5.3	Bill of lading / mate's receipts / exception list* number(s)
5.4	Description of items as shown in bill of lading / mate's receipts / exception list*
5.5	Number of items
5.6	Surface-condition and mechanical-damage clauses superimposed on bill of lading / mate's receipts / exception list*
5.7	Brief description of storage immediately prior to loading
5.8	List of attached photographs illustrating surface-condition and mechanical-damage clauses, and any loading problems encountered

[#] Official weather reports ordered and retained by the surveyor.

* Delete as appropriate.

Appendix II

CHECKLIST FOR WEATHER-DECK OPENINGS SURVEY REPORT

SURVEY	
1.1	Name of surveyor(s)
1.2	Date of report
1.3	Name of person / organisation commissioning survey
1.4	Name of organisation survey commissioned for
1.5	Summary of surveyor's terms of reference
VESSEL	
2.1	Name
2.2	Type
2.3	Gross tonnage
2.4	Port of registry
2.5	Classification society
2.6	Date built
2.7	Place built
2.8	Details of safety construction certificate
2.9	Details of classification certificate
2.10	Details of last load line survey
2.11	Details of last special survey
2.12	Number of cargo holds
2.13	Number of deck hatches per hold
2.14	Hatch closing system
2.15	Number of deck ventilators per hold
2.16	Ventilation system
2.17	Number of sounding pipes per hold
2.18	Number of access openings per hold
2.19	Number and type of other weather-deck openings
2.20	History of previous weather-deck leakage

COMPANIES / PERSONNEL

- | | |
|-----|--|
| 3.1 | Name and address of owner |
| 3.2 | Name and address of manager / operator |
| 3.3 | Name and address of charterer |
| 3.4 | Name of charterer's agent at port of loading |
| 3.5 | Name of owner's agent / P&I correspondent at port of loading |
| 3.6 | Name of master |
| 3.7 | Name of chief officer |
| 3.8 | Names and business of others in attendance |

ACTIVITY REPORT

- | | |
|-----|--|
| 4.1 | Location of loading berth |
| 4.2 | Time and date vessel arrived |
| 4.3 | Time and date surveyor proceeded on board |
| 4.4 | Time and date initial report handed to master (attach copy) |
| 4.5 | Time and date loading commenced |
| 4.6 | Time and date loading completed |
| 4.7 | Time and date vessel departed |
| 4.8 | Full details (including photographs) of weathertightness tests carried out |
| 4.9 | Full details (including photographs) of repairs and adjustments carried out after initial report to master |

OPENINGS REPORT

- | | |
|-----|---|
| 5.1 | Hold number |
| 5.2 | Description of opening and associated closing appliance |
| 5.3 | Condition of opening |
| 5.4 | Condition of closing appliance |
| 5.5 | Condition of flexible joints |
| 5.6 | Condition of securing system |
| 5.7 | Weathertightness of opening prior to voyage |

Appendix III

P&I CLUBS CIRCULAR 28 FEBRUARY 1964

With reference to our circular dated 22nd October, 1963, relating to Letters of Indemnity, experience has since shown that where signs of rust on steel shipments are apparent at the time of shipment, Mates' receipts and Bills of Lading need not necessarily in all cases be claused with the single word "rusty" as stated in sub-paragraph (c) of that circular. Some qualification to the word "rusty" may be justifiable in certain circumstances.

In appropriate cases, therefore, it is permissible for any of the following clauses to be used when describing steel shipments which show signs of rust or a similar condition on shipment:-

Partly rust stained.	Rust and oil spotted.
Rust stained.	Wet before shipment.
Rust spots apparent.	Wet steel tubes.
Some rust spots apparent.	Wet bars.
Rust spots apparent on top sheets.	Rust on metal envelopes.
Some rust spots apparent on top sheets.	Covered with snow.
Top sheets rusty.	Pitted.
Some top sheets rusty.	Rusty.
Rusty edges.	Rust with pitting.
Some rusty edges.	Goods in rusty condition.
Rusty ends.	Edges bent and rusty.
Some rusty ends.	Partly rusty.
Rust spotted.	

When packed sheet iron is shipped the following two clauses may be used:

- Covers rusty / wet.
- Packing rusty / wet.

It must be emphasised that the clause which is used must accurately describe the apparent condition of the steel shipment and must also come within the clauses as set out above.

Apart from sub-paragraph (c) of our circular of 22nd October, 1963, which is accordingly hereby modified by this circular, the remainder of that circular, in particular sub-paragraphs (a) and (b), remains unchanged.

In no case should any reference be made to the degree of rust such as "atmospherically" or "superficially".

INDEX

	<i>Page</i>		<i>Page</i>
Air pipe	22	Ice	7
Angles	9, 19	Inspection of openings	20
Appointing a surveyor	5	International Group clauses	3, 7, 28
Beams	10, 14, 18	Machined surfaces	16
Bilge sounding pipe	20, 21, 26	Mast house doors	21
Bills of lading	3, 6, 25	Mate's receipts	3, 6, 25
Bundles	8, 10, 13, 18	Mechanical-damage clauses	15
Cargo sweat	13	Mill scale	7, 8, 10, 14
Channels	9, 11	Oil patches	7
Chlorides	7, 8	Packing	3, 7, 8, 9, 11, 13, 15, 16, 20
Clauses		Photographs in reports	25, 27
– combining	7, 15	Pipes	13, 15, 16
– mechanical damage	15	Plates	9, 10, 11, 15, 16, 17, 19
– P&I club	3, 7, 28	Powder staining	8
– surface condition	7	Protective coatings	16, 25
Cleats	20, 21	Rails	12
Closing appliances	20, 21, 23	Rain water	6, 20
Coils	9, 11, 12	Reinforcing bars	10
Compression bars of joints	20	Repairs to openings	20, 27
Concrete coating	15	Reports	
Cross-wedges	20, 21	– checklists	24, 26
Disputes	25	– submission	6
Drain holes	20, 21	Rods	15, 16
Edge damage	10, 15, 16, 17, 19	Rubber sealing joints	20, 21, 22, 23
Exception lists	6, 25	Rust	
Flanges	10, 15, 16, 18	– clauses	7
Forklift damage	16, 17	– pitting	8, 11, 12
Galvanising	7, 12, 13	– spots	8, 12, 14
Grease spots	7	– staining	7, 8, 9, 10, 11, 12, 13, 14
Gutterways	20	– streaking	8, 13
Handling damage	7, 10, 15, 16, 17, 19	– white	7, 12
Hatch covers	20	Salt water contact	7, 8, 14
Hollow sections	15	Securing systems	6, 20, 21, 27
Hose testing	21	Sheet piles	16
		Silver nitrate tests	7, 8, 14, 25
		Small scantling pieces	15, 16, 18

INDEX

	<i>Page</i>
Snow	7
Sounding pipe	20, 22, 26
Staining	
– powder	8
– rust	7, 8, 9, 10, 11, 12, 13, 14
Stainless steel	19
Stevedore damages	25
Strapping bands	16, 18, 19
Structural sections	10, 14, 15, 18
Surface-condition clauses	7
Survey reports	
– steel cargo	4, 6, 24
– weather-deck openings	4, 6, 26
Surveyor, appointing	5
Sweat	13
Telescoped coils	16, 17
Terms of reference	5
Ultrasonic testing	21
Ventilators	20, 23, 24, 26
Weathertightness tests	20, 21, 27
Weather reports	25
Weather-deck openings	20, 26
Webs	10, 14, 15
Wet cargo	6, 8, 9, 10
Zinc coating	7

STEEL PRESHIPMENT SURVEYS A GUIDE TO GOOD PRACTICE Second Edition

Arthur Sparks and The North of England P&I Association



This unique illustrated guide is designed to help surveyors and masters worldwide ensure that shipping documents accurately describe the apparent order and condition of steel cargo when loaded. It recommends a set of 18 standard surface-condition clauses and 16 mechanical-damage clauses. Detailed guidance is also provided on the inspection of weather-deck openings. First published in 1993, the guide is now a widely used reference in the international shipping industry. This second edition has a revised layout and minor updates, but the core clauses remain the same.

Captain Arthur Sparks was the leading international expert on the carriage of steel products by sea. His steel surveying activities took him throughout the world and he acted as expert witness in many major maritime steel cargo disputes for over 30 years.

North is a leading marine mutual liability insurer based in Newcastle upon Tyne, UK, with regional offices in Greece, Hong Kong, Japan and Singapore. The Club has developed a worldwide reputation for the quality and diversity of its loss prevention initiatives.

£30
ISBN: 978-0-9558257-3-6