

# No. 84 CONTAINER SHIPS

(2005)  
(Rev.1  
Nov 2017)

## Guidelines for Surveys, Assessment and Repair of Hull Structures

### CONTENTS

1	Introduction	4
2	Class survey requirements	6
2.1	Periodical Classification Surveys	6
2.2	Damage and Repair Surveys	7
2.3	Voyage Repairs and Maintenance	7
3	Technical background for surveys	8
3.1	General	8
3.2	Definitions	8
3.3	Structural Damages and Deterioration	10
3.4	Handling of Defects	12
4	Survey planning, preparation and execution	14
4.1	General	14
4.2	Conditions for Survey	14
4.4	Personal Equipment	16
4.5	Thickness Measurement and Fracture Detection	17
4.6	Survey at Sea or at Anchorage	17
4.7	Documentation on Board	17
5	Structural detail failures and repairs	19
5.1	General	19
5.2	Catalogue of Structural Detail Failures and Repairs	19
Part 1	Cargo hold region	20
Area 1	Upper deck structure including passageways	21
1	General	23
2	What to look for – On-deck inspection	24
2.1	Material wastage	24
2.2	Deformations	24
2.3	Fractures	25
3	What to look for – Under-deck inspection (in passageways)	25
3.1	Material wastage	25
3.2	Deformations	26
3.3	Fractures	26
4.1	Material wastage	26
4.2	Deformations	26
4.3	Fractures	27
4.4	Miscellaneous	27

<b>No.</b>	Area 2 Side structure including side tanks	53
<b>84</b>	1 General	55
(cont)	2 What to look for – Cargo hold inspection	55
	2.1 Material wastage	55
	2.2 Deformations	55
	2.3 Fractures	56
	3.1 Material wastage	56
	3.2 Deformations	57
	4 What to look for – External inspection	57
	4.1 Material wastage	57
	4.2 Deformations	57
	4.3 Fractures	57
	5 General comments on repair	58
	5.1 Material wastage	58
	5.3 Fractures	58
	Sketch of damage	60
	Area 3 Transverse bulkhead structure	73
	1 General	74
	2 What to look for	74
	2.1 Material wastage	74
	2.3 Fractures	75
	3 General comments on repair	75
	3.1 Material wastage	75
	3.2 Deformations	75
	3.3 Fractures	75
	Area 4 Double bottom tank structure	81
	1 General	83
	2 What to look for – Tank top inspection	83
	2.1 Material wastage	83
	2.2 Deformations	83
	2.3 Fractures	83
	3 What to look for – Double bottom tank inspection	84
	3.1 Material wastage	84
	3.2 Deformations	85
	3.3 Fractures	85
	4 What to look for – External bottom inspection	86
	4.1 Material wastage	86
	4.2 Deformations	87
	4.3 Fractures	87
	5.1 Material wastage	87
	5.2 Deformations	87
	5.3 Fractures	87
	Part 2 Fore and aft end regions	101
	Area 1 Fore end structures	102
	1 General	103

<b>No. 84</b> (cont)	2.1	Material wastage	103
	2.2	Deformations	103
	2.3	Fractures	104
	3	General comments on repair	104
	3.1	Material wastage	104
	3.2	Deformations	104
	3.3	Fractures	105
	Area 2	Aft end structures	112
	1	General	113
	2	What to look for	113
	2.1	Material wastage	113
	2.2	Deformations	113
	2.3	Fractures	113
		Figure 1 Aft end structure – Potential problem areas	114
	3	General comments on repair	114
	3.1	Material wastage	114
	3.2	Deformations	114
	3.3	Fractures	114
	Area 3	Stern frame, rudder arrangement and propeller shaft support	119
1	General	120	
2	What to look for – Drydock inspection	123	
2.1	Deformations	123	
2.2	Fractures	123	
2.3	Corrosion/Erosion/Abrasion	124	
3	General comments on repair	124	
3.1	Rudder stock and pintles	124	
3.2	Plate Structure	127	
3.3	Abrasion of bush and sleeve	128	
3.4	Assembling of rudders	128	
3.5	Propeller boss and stern tube	128	
Part 3	Machinery and accommodation spaces	137	
Area 1	Engine room structures	138	
1	General	139	
2	What to look for – Engine room inspection	139	
2.1	Material wastage	139	
2.2	Deformations	139	
3	What to look for – Tank inspection	139	
3.1	Material wastage	139	
4	General comments on repair	140	
4.1	Material wastage	140	
4.2	Deformations	140	
4.3	Fractures	140	
Area 2	Accommodation structure	144	
1	General	145	

## No. 1 Introduction

84  
(cont)

The International Association of Classification Societies (IACS) is introducing a series of Guidelines with the intention of assisting the surveyors of IACS Member Societies and other interested parties involved in the survey, assessment and repair of hull structures of certain ship types.

The present Guidelines are intended for a container ship which is constructed with a single deck, double side skin tanks, passageways and double bottom in the cargo space area, and is intended exclusively to carry cargo in containers in the cargo holds, on deck and on hatch covers. **Figure 1** shows the general view of a typical container ship.

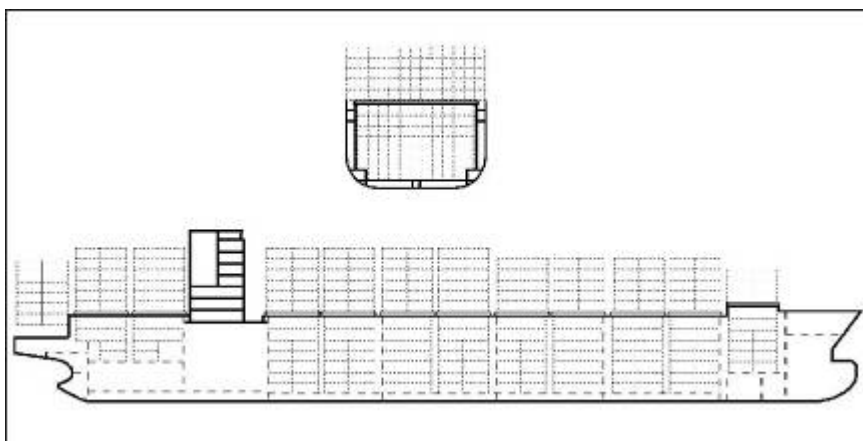

**Figure 1 General view of a typical container ship**

The Guidelines focus on the IACS Member Societies' survey procedures but may also be useful in connection with the inspection/examination schemes of other regulatory bodies, owners and operators.

The Guidelines include a review of survey preparation criteria, which cover the safety aspects related to the performance of the survey, the necessary access facilities, and the other preparation necessary before the surveys can be carried out.

The Guidelines encompass the different main structural areas of the hull where damages have been recorded, focusing on the main features of the structural items of each area.

An important feature of the Guidelines is the inclusion of the section which illustrates examples of structural deterioration and damages related to each structural area and gives what to look for, possible cause, and recommended repair methods, when considered appropriate.

The Procedure for Failure Incident Reporting and Early Warning of Serious Failure Incidents - "Early Warning Scheme - EWS, with the emphasis on the proper reporting of significant hull damages by the respective Classification Societies, will enable the analysis of problems as they arise, including revisions of these Guidelines.

The Guidelines have been developed using the best information currently available. It is intended only as guidance in support of the sound judgment of surveyors, and is to be used at the surveyors' discretion. It is recognized that alternative and satisfactory methods are already applied by surveyors. Should there be any doubt with regard to interpretation or

**No.  
84**  
(cont)

validity in connection with particular applications, clarification should be obtained from the Classification Society concerned.

Figure 2 shows a typical cargo hold structural arrangement.

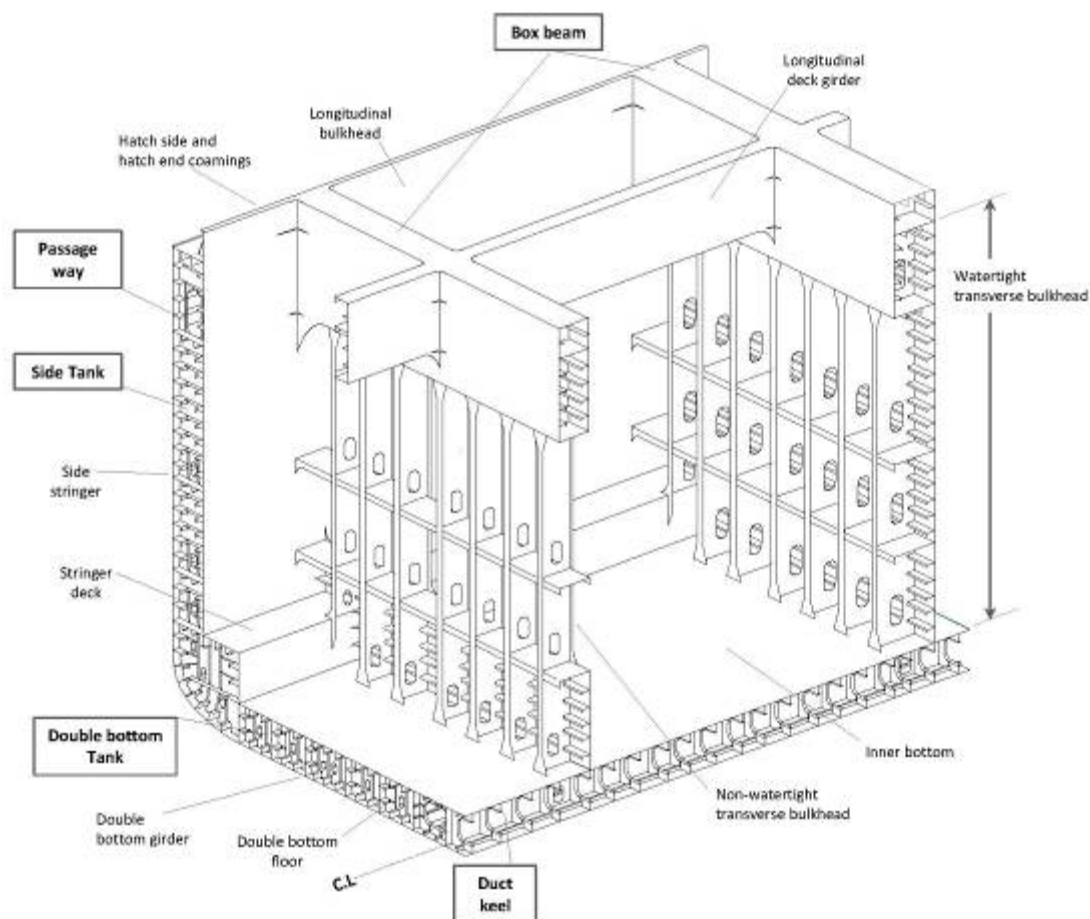

**Figure 2 Typical cargo hold configuration for a container ship**

**No.  
84**  
(cont)**2 Class survey requirements****2.1 Periodical Classification Surveys****2.1.1 General**

For Class the programme of periodical hull surveys is of prime importance as far as structural assessment of the cargo holds and the adjacent tanks is concerned. The programme of periodical hull surveys consists of Annual, Intermediate and Special/Renewal Surveys. The purpose of the Annual and Intermediate Surveys is to confirm that the general condition of the vessel is maintained at a satisfactory level. The Special/Renewal Surveys of the hull structure are carried out at five year intervals with the purpose of establishing the condition of the structure to confirm that the structural integrity is satisfactory in accordance with the Classification Requirements, and will remain fit for its intended purpose until the next Special/Renewal Survey, subject to proper maintenance and operation. The Special/Renewal Surveys are also aimed at detecting possible damage and to establish the extent of any deterioration.

The Annual, Intermediate and Special/Renewal Surveys are briefly introduced in the following 2.1.2 - 2.1.4. The surveys are carried out taking into account the requirements specified in IACS Unified Requirements Z7 (available on the IACS website [www.iacs.org.uk](http://www.iacs.org.uk)), alongside the Rules and Regulations of each IACS Member Society.

**2.1.2 Special/Renewal Survey**

The Special/Renewal Survey concentrates on examination in association with thickness determination. The report of the thickness measurement is recommended to be retained on board. Protective coating condition will be recorded for particular attention during the survey cycle. From 1991 it is a requirement for new ships to apply a protective coating to the structure in water ballast tanks which form part of the hull boundary, and, since 2008, all dedicated seawater ballast tanks are to be coated during construction in accordance with the PSPC (Performance standard for protective coatings for dedicated seawater ballast tanks in all types of ships and double-side skin spaces of bulk carriers), adopted by the Maritime Safety Committee by resolution MSC.215(82).

**2.1.3 Annual Survey**

At Annual Surveys, overall survey is required. For saltwater ballast tanks, examination may be required as a consequence of the Intermediate or Special Surveys.

**2.1.4 Intermediate Survey**

At Intermediate Surveys, in addition to the surveys required for Annual Surveys, examination of cargo holds and ballast tanks is required depending on the ship's age.

**2.1.5 Bottom Survey**

Bottom Surveys are requested twice during the Special Survey interval and they should be generally carried out in dry dock. In some cases it may be possible to replace one Bottom Survey in dry dock with an In-Water Survey. This survey is carried out taking into account the requirements specified in IACS Unified Requirements Z3 (available on the IACS website [www.iacs.org.uk](http://www.iacs.org.uk)), alongside the Rules and Regulations of each IACS Member Society.

**No.  
84**  
(cont)

It is worth to note that the Container ships may be admitted to the Pilot Scheme of Extended Interval between Surveys in Dry-Dock, which allows to schedule the bottom survey in dry dock with a time frame of 7,5 years by permitting that the bottom inspections (two at least) in between are carried out with the ship afloat. The scheme is applicable to ships having age not more than 10 years under the consent of the Flag Administration, The details for the admission to this scheme are set in IACS Recommendation no. 133 (available on the IACS website [www.iacs.org.uk](http://www.iacs.org.uk))

**2.2 Damage and Repair Surveys**

Damage surveys are occasional surveys which are, in general, outside the programme of periodical hull surveys and are requested as a result of hull damage or other defects. It is the responsibility of the owner or owner's representative to inform the Classification Society concerned when such damage or defect could impair the structural capability or watertight integrity of the hull. The damages should be inspected and assessed by the Society's surveyors and the relevant repairs, if needed, are to be performed. In certain cases, depending on the extent, type and location of the damage, permanent repairs may be deferred to coincide with the ~~planned~~-scheduled periodical survey.

**2.3 Voyage Repairs and Maintenance**

Where repairs to hull, machinery or equipment, which affect or may affect classification, are to be carried out by a riding crew during a voyage they are to be planned in advance. A complete repair procedure including the extent of proposed repair and the need for surveyor's attendance during the voyage is to be submitted to and agreed upon by the Surveyor reasonably in advance. Failure to notify the Classification Society, in advance of the repairs, may result in suspension of the vessel's class.

The above is not intended to include maintenance and overhaul to hull, machinery and equipment in accordance with manufacturers' recommended procedures and established marine practice and which does not require the Classification Society's approval; however, any repair as a result of such maintenance and overhauls which affects or may affect classification is to be noted in the ship's log and submitted to the attending Surveyor for use in determining further survey requirements.

See IACS Unified Requirement Z13, available on the IACS website [www.iacs.org.uk](http://www.iacs.org.uk)

**No.  
84**  
(cont)**3 Technical background for surveys****3.1 General**

**3.1.1** The purpose of carrying out periodical hull surveys is to detect possible structural defects and damages and to establish the extent of any deterioration. To help achieve this and to identify key locations on the hull structure that might warrant special attention, knowledge of any historical problems of the particular ship or other ships of a similar class is to be considered if available. In addition to the periodical surveys, occasional surveys of damages and repairs are carried out. Records of typical occurrences and chosen solutions should be available in the ship's history file.

**3.2 Definitions**

**3.2.1** For clarity of definition and reporting of survey data, it is recommended that standard nomenclature for structural elements be adopted. Typical sections in way of cargo holds are illustrated in **Figures 3 (a) and (b)**. These figures show the generally accepted nomenclature.

The terms used in these guidelines are defined as follows:

(a) **Ballast Tank** is a tank which is used primarily for salt water ballast.

(b) **Spaces** are separate compartments including holds and tanks.

(c) **Close-up Survey** is a survey where the details of structural components are within the close visual inspection range of the surveyors, i.e. normally within reach of hand.

(d) **Transverse Section** includes all longitudinal members such as plating, longitudinals and girders at the deck, sides, longitudinal bulkheads, bottom and inner bottom. For transversely framed vessels, a transverse section includes adjacent frames and their end connections in way of transverse sections.

(e) **Representative Spaces** are those which are expected to reflect the condition of other spaces of similar type and service and with similar corrosion protection systems. When selecting representative spaces, account should be taken of the service and repair history on board.

(f) **Suspect Areas** are locations showing substantial corrosion and/or are considered by the surveyor to be prone to rapid material wastage.

(g) **Substantial Corrosion** is an extent of corrosion such that assessment of corrosion pattern indicates a material wastage in excess of 75 per cent of allowable margins, but within acceptable limits.

(h) **Coating Condition** is defined as follows:

Good — condition with only minor spot rusting.

Fair — condition with local breakdown at edges of stiffeners and weld connections and/or light rusting over 20 per cent or more of areas under consideration, but less than as defined for Poor condition.

Poor — condition with general breakdown of coating over 20 per cent or more of areas or hard scale at 10 per cent or more of areas under consideration.



**No. 84**  
(cont)

(i) **Transition Region** is a region where discontinuity in longitudinal structure occurs, e.g. at forward bulkhead of engine room, collision bulkhead and bulkheads of deep tanks in cargo hold region.

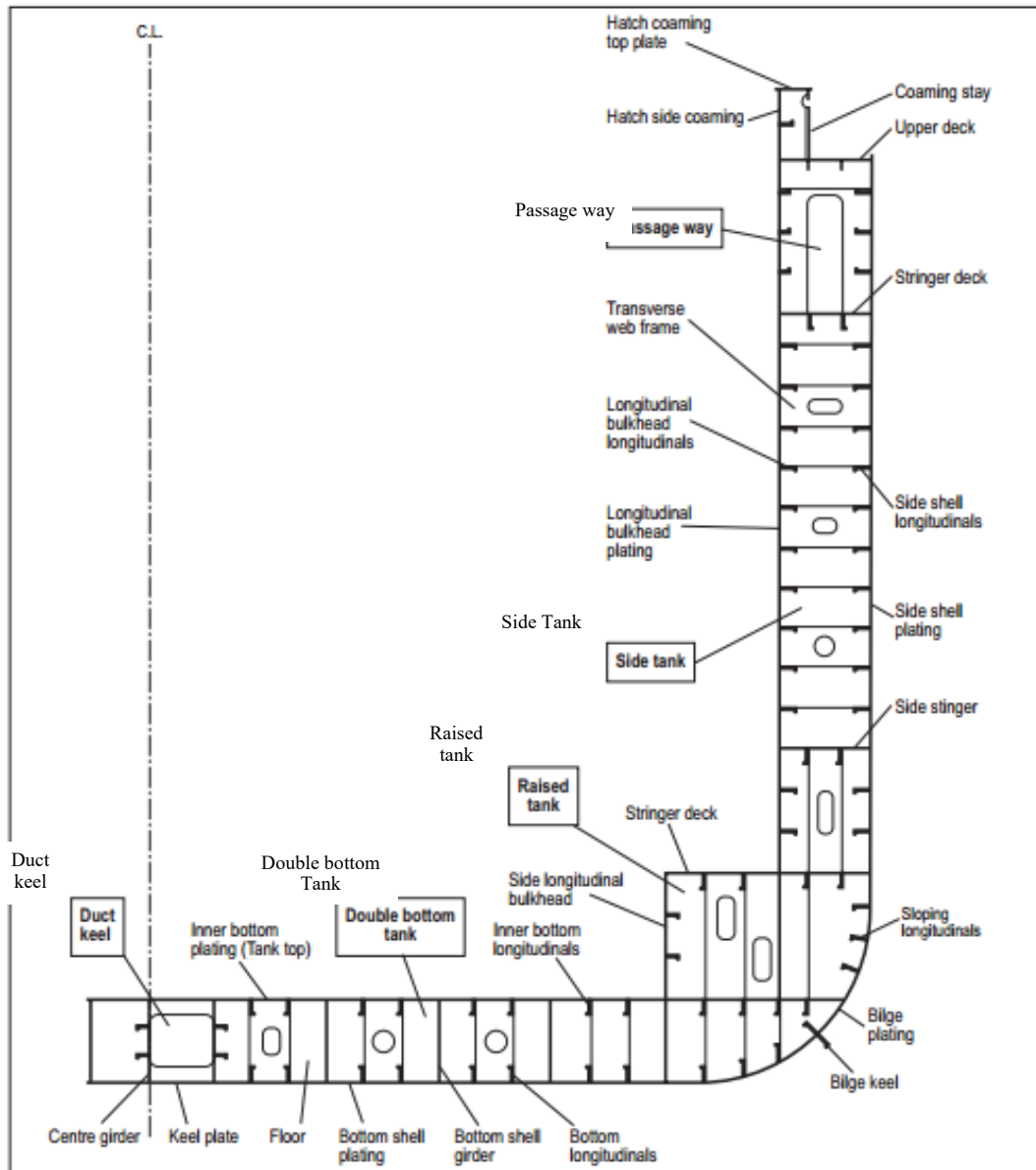

**Figure 3 (a) Nomenclature for typical transverse section in way of cargo hold**

# No. 84

(cont)

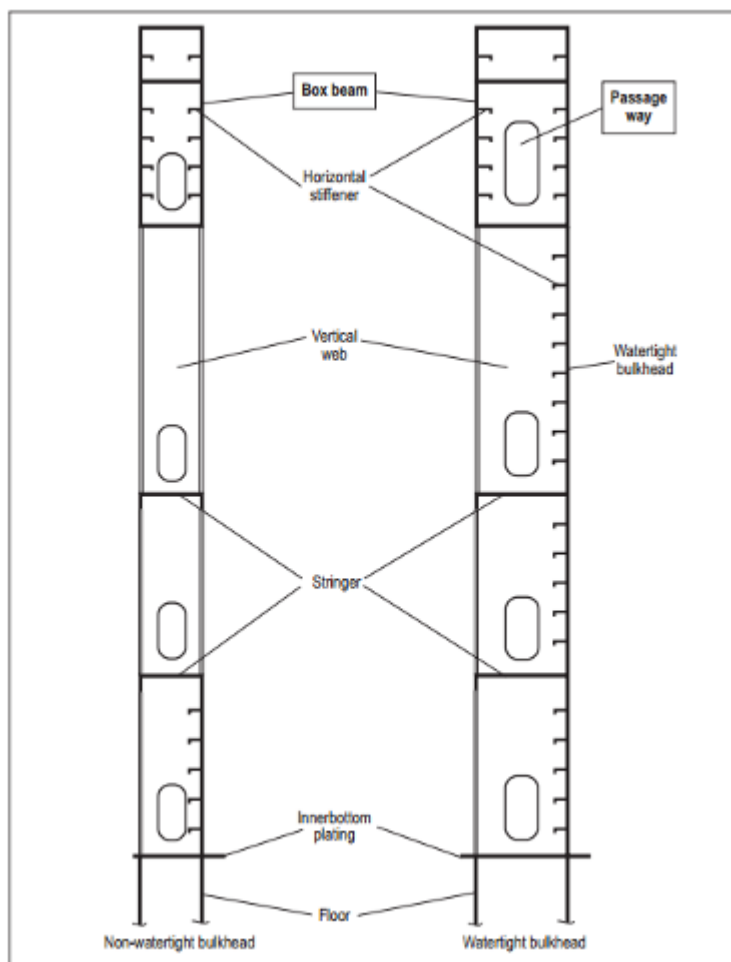

**Figure 3 (b) Nomenclature for typical transverse bulkheads**

## 3.3 Structural Damages and Deterioration

### 3.3.1 General

In the context of these Guidelines, structural damages and deterioration imply deficiencies caused by:

- excessive corrosion
- design faults
- material defects or bad workmanship
- navigation in extreme weather conditions
- loading and unloading operations, water ballast exchange at sea
- wear and tear
- contact (with quay side, ice, touching underwater objects, etc, but not as a direct consequence of accidents such as collisions, groundings and fire/explosions.)
- Deficiencies are normally recognized as:
  - material wastage
  - fractures
  - deformations

**No.  
84**  
(cont)

The various types of deficiencies and where they may occur are discussed in more detail as follows:

**3.3.2 Material wastage**

In addition to being familiar with typical structural defects likely to be encountered during a survey, it is necessary to be aware of the various forms and possible location of corrosion that may occur to the decks, holds, tanks and other structural elements.

**General corrosion** appears as a non-protective, friable rust which can occur uniformly on hold or tank internal surfaces that are uncoated. The rust scale continually breaks off, exposing fresh metal to corrosive attack. Thickness loss cannot usually be judged visually until excessive loss has occurred. Failure to remove mill scale during construction of the ship can accelerate corrosion experienced in service. Severe general corrosion in all types of ships, usually characterized by heavy scale accumulation, can lead to extensive steel renewals.

**Grooving corrosion** is often found in or beside welds, especially in the heat affected zone. The corrosion is caused by the galvanic current generated from the difference of the metallographic structure between the heat affected zone and base metal. Coating of the welds is generally less effective compared to other areas due to roughness of the surface which exacerbates the corrosion. Grooving corrosion may lead to stress concentrations and further accelerate the corrosion process. Grooving corrosion may be found in the base material where coating has been scratched or the metal itself has been mechanically damaged.

**Pitting corrosion** is often found in the bottom plating or in horizontal surfaces, such as face plates, in ballast tanks and is normally initiated due to local breakdown of coating.

**Erosion** which is caused by the wearing effect of flowing liquid and abrasion, which is caused by mechanical actions, may also be responsible for material wastage.

**3.3.3 Fractures**

In most cases fractures are found at locations where stress concentrations occur. Weld defects, flaws, and where lifting fittings used during the construction of the ship are not properly removed are often recognized as areas of stress concentration when fractures are found. If fractures occurred under repeated stresses which are below the yielding stress, the fractures are called fatigue fractures. In addition to the cyclic stresses caused by wave forces, fatigue fractures are also caused by vibration forces derived from main engine(s) or propeller(s), especially in the afterward part of the hull. If the initiation points of the fractures are not apparent, the structure on the other side of the plating should be examined.

Fractures may not be readily visible due to lack of cleanliness, difficulty of access, poor lighting or compression of the fracture surfaces at the time of inspection. It is therefore important to identify, clean, and closely inspect potential problem areas.

A fracture initiating at latent defects in welds more commonly appears at the beginning or end of a run of welds, at rounding corners at the end of a stiffener, or at an intersection. Special attention should be paid to welds at toes of brackets, at cut-outs and at intersections of welds. Fractures may also be initiated by undercutting the weld in way of stress concentrations. Although now less common, intermittent welding may cause problems because of the introduction of stress concentrations at the end of each length of weld.

**No.  
84**  
(cont)

It should be noted that fractures, particularly fatigue fractures due to repeated stresses, may lead to serious damage, e.g. a fatigue fracture in a frame may propagate into shell plating and affect the watertight integrity of the hull. In extreme weather conditions the shell fracture could extend further resulting in the loss of part of the shell plating and consequent flooding of side tank.

When a ship are built with extremely thick steel plates (with thickness of over 50mm) to longitudinal structural members in the upper deck and hatch coaming structural region (i.e. upper deck plating, hatch side coaming and hatch coaming top), when NDT is required by rules of each Classification Societ, NDT should be carried out in accordance with the requirements of IACS UR S33

During the in tank inspections, careful inspections for latent fractures should be made to the structures where the hard coating is found broken down alongside (transverse) the block-joint butt welds in tanks with coating in a general good condition. These might be caused by stress concentrations.

### 3.3.4 Deformations

Deformation of structure is caused by in-plane load, out-of-plane load or combined loads. Such deformation is often identified as local deformation, i.e. deformation of a panel or stiffener, or global deformation, i.e. deformation of a beam, frame, girder or floor, including associated plating.

If a small increase of the in-plane loads cause large deformations, this process is called buckling.

Deformations are often caused by impact loads/contact and inadvertent overloading. Damages due to bottom slamming and wave impact forces are, in general, found in the forward part of the hull, although stern seas (pooping) have resulted in damages in way of the after part of the hull.

In the case of damage due to contact with other objects, special attention should be drawn to the fact that although damage to the shell plating may look small from the outboard side, in many cases the internal members are heavily damaged.

Permanent buckling may arise as a result of overloading, overall reduction in thickness due to corrosion, or contact damage. Elastic buckling will not normally be directly obvious but may be detected by evidence of coating damage, stress lines or shedding of scale.

Buckling damage may often be found in webs of web frames or floors. In many cases, this may be attributed to corrosion of webs/floors, wide stiffener spacing or wrongly positioned lightening holes, man-holes or slots in webs/floors.

Finally, it should be noted that inadvertent overloading may cause significant damage. In general, however, major damage is associated with excessive corrosion and contact damage.

## 3.4 Handling of Defects

**3.4.1** Surveyors and inspectors should be familiar with the examples of structural defects and the repairs which are outlined in Section 5 of these Guidelines before undertaking a survey.

**3.4.2** Any damage to ships structures that is considered to affect the ship's Classification is to be repaired.

**3.4.3** Before carrying out major repairs involving design modification, drawings are to be

**No.**  
**84**  
(cont)

submitted to the Classification Society for approval.

**3.4.4** In general, where part of the structure has deteriorated to the permissible minimum thickness, the affected area is to be cropped and renewed. Doubler plates must not be used for the compensation of wasted plate. Repair work in tanks requires careful planning in terms of accessibility.

**3.4.5** For structures subject to net scantling approach as per the Unified Requirements of IACS (Refer to UR S11A and S21A) or the rules of the Classification Society, steel renewal is required where the gauged thickness is less than  $t_{\text{renewal}}$  ( $t_{\text{net}}$  or  $t_{\text{net}} + 0.5$  mm, depending on the corrosion addition assigned to the structures). Where the gauged thickness is within the range  $t_{\text{renewal}} + 0.5$  mm, coating (applied in accordance with the coating manufacturer's requirements) or annual gauging may be adopted as an alternative to steel renewal, and the coating is to be maintained in GOOD condition.

**3.4.6** If replacement of defective parts may be allowed to be postponed, the following temporary measures may be acceptable at the surveyor's discretion (notwithstanding that carrying out a permanent repair straightaway is the preferable option):

- (a) the affected area may be sandblasted and painted in order to reduce corrosion rate.
- (b) doubler plates may be applied over the affected area. Special consideration should be given to areas buckled under compression.
- (c) stronger members may support weakened stiffeners by applying temporarily connecting elements.
- (d) cement box may be applied over the affected area.

A suitable condition of class is imposed by the class surveyor when temporary measures are accepted.

**3.4.7** When the repair is performed afloat, the ship loading condition is to be adjusted to have a longitudinal stress at deck less than 50 MPa.

**3.4.8** For controlling the quality of repair of hull structures, the standard of part B of IACS Recommendation 47 "Shipbuilding and Repair Quality Standard" or equivalent standards recognized by the classification society, should be followed.

**No.  
84**  
(cont)**4 Survey planning, preparation and execution****4.1 General**

**4.1.1** The Owner should be aware of the scope of the coming survey and instruct those who are responsible, such as the Master or the Superintendent, to prepare the necessary arrangements. If there is any doubt, the Classification Society concerned should be consulted.

**4.1.2** Survey execution will naturally be heavily influenced by the type and scope of the survey to be carried out. The scope of survey is normally determined prior to its execution

**4.1.3** When deemed prudent and/or required by virtue of the periodic classification survey conducted, the Surveyor should study the ship's structural arrangements and review the ship's operating and survey history and those of sister ships, where possible, to determine any known potential problem areas particular to the class of the ship. Sketches of typical structural elements should be prepared in advance so that any defects and/or ultrasonic thickness measurements can be recorded rapidly and accurately.

**4.2 Conditions for Survey**

**4.2.1** The owner is to provide the necessary facilities for a safe execution of the survey.

**4.2.2** Tanks and spaces are to be safe for access, i.e. gas freed (marine chemist certificate), ventilated, etc. Reference could be made to IACS Procedural Requirement 37 dealing with the safe entry into confined spaces.

**4.2.3** Tanks and spaces are to be sufficiently clean and free from water, scale, dirt, oil residues, etc. and sufficient illumination is to be provided, to reveal corrosion, deformation, fractures, damages or other structural deterioration. In particular this applies to areas which are subject to thickness measurement.

**4.3 Access Arrangement and Safety**

**4.3.1** In accordance with the intended survey, measures are to be provided to enable the hull structure to be examined and the thickness measurements to be carried out in a safe and practical way.

**4.3.2** For surveys in cargo holds and salt water ballast tanks one or more of the following means of access, acceptable to the Surveyor, are to be provided:

- (a) permanent staging and passages through structures
- (b) temporary staging, e.g. ladders and passages through structures
- (c) lifts and movable platforms; and
- (d) other equivalent means.

**4.3.3** In addition, particular attention should be given to the following guidance:

1. Prior to entering tanks and other closed spaces, e.g. chain lockers, void spaces, it is necessary to ensure that the oxygen content is tested and confirmed as safe. A responsible member of the crew should remain at the entrance to the space and if possible communication links should be established with both the bridge and engine room. Adequate lighting should be provided in addition to a hand held torch (flashlight).

**No.  
84**  
(cont)

2. In tanks where the structure has been coated and recently deballasted, a thin slippery film may often remain on surfaces. Care should be taken when inspecting such spaces.
3. The removal of scale can be extremely difficult. The removal of scale by hammering may cause sheet scale to fall, and in cargo holds this may result in residues of cargo falling from above. When using a chipping or scaling hammer care should be taken to protect eyes, and where possible safety glasses should be worn. If the structure is heavily scaled then it may be necessary to request de-scaling before conducting a satisfactory visual examination.
4. Owners or their representatives have been known to request that a survey be carried out from the top of the cargo during loading and unloading operations. For safety reasons, loading and unloading operations must be stopped in the hold being surveyed.
5. When entering a cargo hold or tank the bulkhead vertical ladders should be examined prior to descending to ensure that they are in good condition and rungs are not missing or loose. If holds are being entered when the hatch covers are in the closed position, then adequate lighting should be arranged in the holds. One person at a time should descend or ascend the ladder.
6. If a portable ladder is used for survey purposes, the ladder should be in good condition and fitted with adjustable feet, to prevent it from slipping. Two crew members should be in attendance in order that the base of the ladder is adequately supported during use.
7. If an extending/articulated ladder (frame walk) is used to enable the examination of upper portions of cargo hold structure, the ladder should incorporate a hydraulic locking system and a built-in safety harness. Regular maintenance and inspection of the ladder should be confirmed prior to its use.
8. If a hydraulic arm vehicle ("Cherry Picker") is used to enable the examination of the upper parts of the cargo hold structure, the vehicle should be operated by qualified personnel and there should be evidence that the vehicle has been properly maintained. The standing platform should be fitted with a safety harness. For those vehicles equipped with a self-leveling platform, care should be taken that the locking device is engaged after completion of manoeuvring to ensure that the platform is fixed.
9. Staging is the most common means of access provided especially where repairs or renewals are being carried out. It should always be properly supported and fitted with handrails. Planks should be free from splits and lashed down. Staging erected hastily by inexperienced personnel should be avoided.
10. In double bottom tanks there will often be an accumulation of mud on the bottom of the tank and this should be removed, in particular in way of tank boundaries, and suction and sounding pipes, to enable a clear assessment of the structural condition.

**No.  
84**  
(cont)**4.4 Personal Equipment<sup>1</sup>**

**4.4.1** The following protective clothing and equipment to be worn as applicable during the surveys:

- (a) **Working clothes:** Working clothes should be of a low flammability type and easily visible.
- (b) **Head protection:** Hard hat (metal hats are not allowed) shall always be worn outside office building/unit accommodation.
- (c) **Hand and arm protection:** Various types of gloves are available for use, and these should be used during all types of surveys. Rubber/plastic gloves may be necessary when working in cargo holds.
- (d) **Foot protection:** Safety shoes or boots with steel toe caps and non-slip soles shall always be worn outside office buildings/unit accommodation. Special footwear may be necessary on slippery surfaces or in areas with chemical residues.
- (e) **Ear protection:** Ear muffs or ear plugs are available and should be used when working in noisy areas. As a general rule, you need ear protection if you have to shout to make yourself understood by someone standing close to you.
- (f) **Eye protection:** Goggles should always be used when there is danger of getting solid particles or dust into the eyes. Protection against welding arc flashes and ultraviolet light should also be considered.
- (g) **Breathing protection:** Dust masks shall be used for protection against the breathing of harmful dust, paint spraying and sand blasting. Gas masks and filters should be used by personnel working for short periods in an atmosphere polluted by gases or vapour. (Self-contained breathing apparatus: Surveyors shall not enter spaces where such equipment is necessary due to the unsafe atmosphere. Only those who are specially trained and familiar with such equipment should use it and only in case of emergency).
- (h) **Lifejacket:** Recommended to wear when embarking/disembarking ships offshore, from/to pilot boat.

**4.4.2** The following survey equipment is to be used as applicable during the surveys:

- (a) **Torches:** Torches (Flashlights) approved by a competent authority for use in a flammable atmosphere shall be used in gas-dangerous areas. A high intensity beam type is recommended for in-tank inspections. Torches are recommended to be fitted with suitable straps so that both hands may be free.
- (b) **Hammer:** In addition to its normal purposes the hammer is recommended for use during surveys inside units, tanks etc. as it may be most useful for the purpose of giving a distress signal in the case of an emergency.
- (c) **Oxygen analyser/Multigas detector:** For verification of an acceptable atmosphere prior to tank entry, pocket size instruments which give an audible alarm when unacceptable limits are reached, are recommended. Such equipment shall have been approved by national authorities.

---

<sup>1</sup> Reference should also be made to IACS PR37 and IACS Recommendation 72



**No.  
84**  
(cont)

(d) **Safety belts and lines:** Safety belts and lines should be worn where there is a high risk of falling from more than 3 meters.

**4.5 Thickness Measurement and Fracture Detection**

**4.5.1** Thickness measurement is to comply with the requirements of the Classification Society concerned. Thickness measurement should be carried out at points that adequately represent the nature and extent of any corrosion or wastage of the respective structure (plate, web, etc.)

**4.5.2** Thickness measurement is normally carried out by means of ultrasonic test equipment. The accuracy of the equipment is to be proven as required.

**4.5.3** The required thickness measurements, if not carried out by the Classification Society itself, are to be carried out by a qualified company certified by the relevant Classification Society, and are to be witnessed by a surveyor on board to the extent necessary to control the process. The report is to be verified by the surveyor in charge.

**4.5.4** One or more of the following fracture detection procedures may be required if deemed necessary and should be operated by experienced qualified technicians:

- (a) radiographic equipment
- (b) ultrasonic equipment
- (c) magnetic particle equipment
- (d) dye penetrant

**4.6 Survey at Sea or at Anchorage<sup>2</sup>**

**4.6.1** Voyage surveys may be accepted provided the survey party is given the necessary assistance from the shipboard personnel. The necessary precautions and procedures for carrying out the survey are to be in accordance with previous paragraphs. The ballasting system must be secured at all times during tank surveys.

**4.6.2** A communication system is to be arranged between the survey party in the spaces under examination and the responsible officer on deck.

**4.7 Documentation on Board**

**4.7.1** The following documentation is recommended to be placed on board and maintained and updated by the owner for the life of the ship in order to be readily available for the survey party.

**4.7.2 Survey Report File:** This file includes Reports of Structural Surveys and Thickness Measurement Reports.

**4.7.3 Supporting Documents:** The following additional documentation is recommended to be placed on board, including any other information that will assist in identifying Suspect Areas requiring examination.

- (a) main structural plans of cargo holds and ballast tanks
- (b) previous repair history
- (c) cargo and ballast history
- (d) inspection and action taken by ship's personnel with reference to:

---

<sup>2</sup> Reference could be made to IACS Procedural Requirement 37 dealing with the safe entry into confined spaces

**No.**  
**84**  
(cont)

- structural deterioration in general
- leakages in bulkheads and piping
- condition of coating or corrosion protection, if any

**4.7.4** Prior to inspection, it is recommended that the documents on board the vessel be reviewed, as a basis for the current survey.

**No.  
84**  
(cont)**5 Structural detail failures and repairs****5.1 General**

**5.1.1** The listing of structural detail failures and repairs contained in this section of the Guidelines collates data supplied by the IACS Member Societies and is intended to provide guidance when considering similar cases of damage and failure. The proposed repairs reflect the experience of the surveyors of the Member Societies, but it is realized that other satisfactory alternative methods of repair may be available. However, in each case the repairs are to be completed to the satisfaction of the Classification Society surveyor concerned.

**5.2 Catalogue of Structural Detail Failures and Repairs**

**5.2.1** The listing has been sub-divided into parts and areas to be given particular attention during surveys:

**Part 1 Cargo hold region**

**Area 1 – Upper deck structure including passageways**

**Area 2 – Side structure including side tanks**

**Area 3 – Transverse bulkheads**

**Area 4 – Double bottom structure**

**Part 2 Fore and aft end regions**

**Area 1 – Fore end structure**

**Area 2 – Aft end structure**

**Area 3 – Stern frame, rudder arrangement and propeller shaft support**

**Part 3 Machinery and accommodation spaces**

**Area 1 – Engine room structure**

**Area 2 – Accommodation structure**

**No. Part 1 Cargo hold region**

**84**

(cont)

Contents

Area 1 – Upper deck structure including passageways

Area 2 – Side structure including side tanks

Area 3 – Transverse bulkheads

Area 4 – Double bottom

---

**No. 84**      **Area 1 Upper deck structure including passageways****84**  
(cont)**Contents**

- 1      General**
  
- 2      What to look for – On-deck inspection**
  - 2.1    Material wastage**
  - 2.2    Deformations**
  - 2.3    Fractures**
  
- 3      What to look for – Under-deck inspection**
  - 3.1    Material wastage**
  - 3.2    Deformations**
  - 3.3    Fractures**
  
- 4      General comments on repair**
  - 4.1    Material wastage**
  - 4.2    Deformations**
  - 4.3    Fractures**
  - 4.4    Miscellaneous**

**Figures – Area 1**

<b>No.</b>	<b>Title</b>
<b>Figure 1</b>	<b>Simulation – bending of the ship in a seaway</b>

# No. 84

(cont)

## Examples of structural detail failures and repairs – Area 1

Example No.	Title
1	Buckling of deck plating of transverse framing system
2-a	Fractures at main cargo hatch corner
2-b	Fractures at main cargo hatch corner initiated from welded joint of cell guide
2-c	Fractures at main cargo hatch corner initiated sniped end of stiffener
3-a	Fracture of welded seam between thick plate and thin plate at cross deck
3-b	Plate buckling in thin plate near thick plate at cross deck
3-c	Overall buckling of cross deck plating
3-d	Deformed and fractured deck plating around tug bitt
4	Fracture in deck girder initiated at bracket toe
5	Fractures in continuous longitudinal hatch coaming extension bracket
6	Fractures in hatch side coaming
7	Fracture in access hole of longitudinal hatch coaming
8-a	Fractures in hatch coaming top plate at the termination of rail for hatch cover
8-b	Fractures in hatch coaming top plate at the termination of rail for hatch cover
9	Fractures in hatch coaming top plate initiated from butt weld of compression bar
10	Fracture in hatch coaming top plate i.w.o. quick acting cleat
11	Fractures in hatch coaming top plate around resting pad
12-a	Fractures in web of transverse hatch coaming stay
12-b	Fractures in web of transverse hatch coaming stay
13	Fractures in the connection of the web of transverse hatch coaming stay
14	Fracture in deck longitudinal
15	Fractures in longitudinal hatch cover girder
16	Fractures in deck girder
17	Fractures in the connections between hatch coaming and bulkhead of deck house
18	Fracture in deck plating at the pilot ladder access of bulwarks

# No. 84

(cont)

## 1 General

**1.1** Due to the large hatch openings for loading and unloading of containers the hull structure is very flexible showing considerable elastic deformations in a seaway as well as high longitudinal stresses. Normally container ships meet only hogging still water bending moment conditions of the hull causing high tensile stresses in the continuous longitudinal deck structures such as longitudinal hatch coamings, upper deck plating and longitudinals. The range of these higher bending stresses is extended over the complete cargo hold area. Particular areas of the deck may also be subjected to additional compressive stresses in heavy weather, caused by slamming or bow flare effect at the fore part of the ship. Longitudinal deck girders, even though in general not completely effective for the longitudinal hull girder strength, are also subject to high longitudinal stresses. In particular in case of the use of higher tensile steel in such high stressed areas special attention is to be paid to the detail design of the structure.

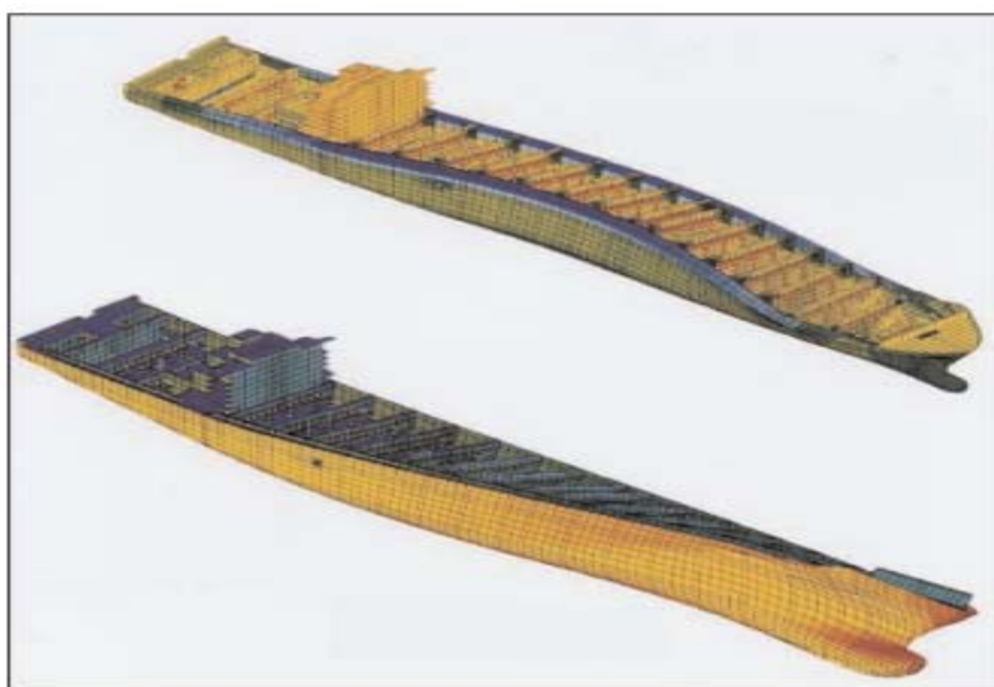

**Figure 1 Simulation – bending of the ship in a seaway**

**1.2** The cross deck structure between cargo hatches is subjected to transverse compression from the sea pressure on the ship sides and in-plane bending due to torsional distortion of the hull girder under wave action. In association with this, the area around the corners of a main cargo hatch is subjected to high cyclical stresses due to the combined effect of hull girder bending moments, transverse and torsional loads.

**1.3** Cargo hatch side coamings can be subjected to stress concentrations at their ends.

**1.4** Considerable horizontal frictional forces in way of the hatch cover resting pads can result from the elastic deformation of the deck structure in combination with the hatch covers which are extremely rigid against horizontal in-plane loads. The magnitude of these frictional forces depends on the material combination in way of the bearing.

**1.5** Hatch cover operations, combining with poor maintenance, can result in damage to cleats and gaskets leading to the loss of weathertight integrity of the hold spaces. Damage to hatch covers can also be sustained by mishandling and overloading of deck cargoes.

**No.  
84**  
(cont)

**1.6** The marine environment, and the high temperature on deck and hatch cover plating due to heat from the sun may result in accelerated corrosion of plating and stiffeners making the structure more vulnerable to the exposures described above.

**1.7** The deterioration of fittings on deck, such as ventilators, air pipes and sounding pipes, may result in serious problems regarding weather/watertightness and/or firefighting.

## **2 What to look for – On-deck inspection**

### **2.1 Material wastage**

**2.1.1** The general corrosion condition of the deck structure, cargo hatch covers and coamings may be observed by visual inspection. Special attention should be paid to areas where pipes, e.g. fire main pipes, hydraulic pipes and pipes for compressed air, are fitted close to the plating, making proper maintenance of the protective coating difficult to carry out. Severe corrosion of the hatch coaming plating inside cargo holds may occur due to difficult access for the maintenance of the protective coating. This may lead to fractures in the structure.

**2.1.2** Grooving corrosion may occur at the transition between the thicker deck plating outside the line of cargo hatches and the thinner cross deck plating, especially when the difference in plate thickness is large. The difference in plate thickness causes water to gather in this area resulting in a corrosive environment which may subsequently lead to grooving.

**2.1.3** Pitting corrosion may occur throughout the cross deck strip plating and on hatch covers. Water accumulation may create additional corrosion.

**2.1.4** Wastage/corrosion may affect the integrity of steel hatch covers and the associated moving parts, e.g. cleats, pot-lifts, roller wheels, etc. For a ship provided with partially weathertight hatchway covers (referring to the IMO circular MSC/Circ.1087, Guidelines for Partially Weathertight Hatchway Covers onboard Container Ships), particular attention should be paid during inspection to the wastage/corrosions of the related fittings on the top plates of hatchway in way of the non-weathertight connections of hatch covers.

### **2.2 Deformations**

**2.2.1** Plate buckling (between stiffeners) may occur in areas subjected to in-plane compressive stresses, in particular if affected by corrosion. Special attention should be paid to areas where the compressive stresses are perpendicular to the direction of the stiffening system. Such areas may be found in the fore part of the ship where deck longitudinals are terminated and replaced by transverse beams (See **Example 1**) as well as in the cross deck strips between hatches when longitudinal stiffening is applied (See **Examples 3-b** and **3-c**).

**2.2.2** Deformed structure may be observed in areas of the deck, hatch coamings, hatch covers and lashing equipment where cargo has been handled/loaded or mechanical equipment, e.g. hatch covers, has been operated. In exposed deck areas, in particular the forward deck, deformation of structure may be as a result of green seas loads on the deck.

**2.2.3** Deformation/distorting of exposed structure above deck, such as side-coaming brackets, may result from impact due to improper handling of cargo and cargo handling machinery. Such damage may also be caused by shipping green sea water on deck in heavy weather.

**2.2.4** Hatch cover deformation may be caused by wave loads acting on containers loaded on hatch covers and by dynamic mass forces.



**No.  
84**  
(cont)

**2.2.5** Deck plate deformation may be detected in way of the connections between tug bitt and deck plating (See **Examples 3-d**).

**2.3 Fractures**

**2.3.1** Fractures in areas of structural discontinuity and stress concentration will normally be detected by inspection. Special attention should be given to the structures at cargo hatches in general and to corners of deck openings in particular.

**2.3.2** Fractures initiated in the deck plating outside the line of the hatch (See **Example 2-a, 2-b** and **2-c**) may propagate across the deck resulting in serious damage to hull structural integrity. Fractures initiated in the deck plating of the cross deck strip, in particular at the transition between the thicker deck plating and the thinner cross deck plating (see **Example 3-a**), may cause serious consequences if not repaired immediately.

**2.3.3** Deck plate fractures may be detected in way of the connections between tug bitt and deck plating (See **Examples 3-d**).

**2.3.4** Other fractures that may occur in the deck plating at hatches and in connected coamings can result/originate from:

- (a) the geometry of the corners of the hatch openings.
- (b) welded attachment on the free edge of the hatch corner plating. (See **Example 2-b**).
- (c) fillet weld connection of the coaming to deck.
- (d) attachments, cut-outs and notches for securing devices, and operating mechanisms for opening/closing hatch covers at the top of the coaming and/or coaming top bar (See **Examples 8-a, 8-b and 9**).
- (e) hatch coaming stays supporting the hatch cover resting pads and the connection of resting pads to the top of the coaming as well as the supporting structures. (See **Example 11**).
- (f) the termination of the side coaming extension brackets (See **Examples 5**).
- (g) in way of lashing equipment connections.

**2.3.5** Fractures in deck plating often occur at the termination of bulwarks, such as pilot ladder recess, due to stress concentration. The fractures may propagate resulting in a serious hull failure when the deck is subject to high longitudinal bending stress.

**3 What to look for – Under-deck inspection (in passageways)****3.1 Material wastage**

**3.1.1** The level of wastage of under-deck stiffeners and structures in cross deck structures may have to be established by means of thickness measurements. As mentioned previously the combination of the effects from the marine environment and the local atmosphere will give rise to high corrosion rates.

**No.  
84**  
(cont)**3.2 Deformations**

**3.2.1** Deformation of the side shell transverse web frames and/or distortions of side shell longitudinals may occur due to external loads imposed on the structure in way of the tug pushing area, or in way of side shell fenders.

**3.2.2** Improper ventilation during ballasting/deballasting of ballast tanks may cause deformation in deck structures. If such deformation is observed, an internal inspection of the ballast tank should be carried out in order to confirm the nature and the extent of damage.

**3.3 Fractures**

**3.3.1** Fractures may be found in way of the connection between deck longitudinals and transverse bulkheads in particular at the end of supporting brackets.

**4 General comments on repair****4.1 Material wastage**

**4.1.1** In the case of grooving corrosion at the transition between the thicker deck plating outside the line of cargo hatches and the thinner cross deck plating, consideration should be given to renewal of part of, or the entire width of, the adjacent cross deck plating.

**4.1.2** In the case of pitting corrosion throughout the cross deck strip plating, consideration should be given to renewal of part of or the entire cross deck plating.

**4.1.3** When heavy wastage is found on deck structure, the whole or part of the structure may be cropped and renewed depending on the permissible diminution levels allowed by the Classification Society concerned.

**4.1.4** For wastage of cargo hatch covers a satisfactory thickness determination is to be carried out and the plating and stiffeners are to be cropped and renewed as appropriate depending on the extent of the wastage.

**4.2 Deformations**

**4.2.1** When buckling of the deck plating has occurred, appropriate reinforcement is necessary in addition to cropping and renewal, regardless of the corrosion condition of the plating.

**4.2.2** Cross deck structure, buckled due to loss in strength caused by wastage, is to be cropped and renewed as necessary. If the cross deck is stiffened longitudinally and the buckling results from inadequate transverse strength, additional transverse stiffeners should be fitted (See **Example 3-b** and **3-c**).

**4.2.3** Deformations of cargo hatch covers should be cropped and part renewed, or renewed in full, depending on the extent of the damage.

**No.**  
**84**  
(cont)**4.3 Fractures**

**4.3.1 Fractures in way of cargo hatch corners should be carefully examined in conjunction with the design details (See Example 2-a, 2-b and 2-c).** Re-welding of such fractures is normally not considered to be a permanent solution. Where the difference in thickness between an insert plate and the adjacent deck plating is greater than 3 mm, the edge of the insert plate should be suitably beveled. In order to reduce the residual stress arising from this repair situation, the welding sequence and procedure is to be carefully monitored and low hydrogen electrodes should be used for welding the insert plate to the adjoining structure.

**4.3.2** Where structures such as cell guides which are welded to the corners of the hatch openings are considered to be the cause of the fractures, the connection should be modified. (See **Example 2-b**).

**4.3.3** In the case of fractures at the transition between the thicker deck plating outside the line of cargo hatches and the thinner cross deck plating, as well as in the hatch side coaming, consideration should be given to renew part of or the entire width of the adjacent cross deck plating, possibly with increased thickness (See **Example 3-a**).

**4.3.4** When fractures have occurred in deck girders or connection of deck girders to the transverse bulkhead without significant corrosion, appropriate reinforcement should be considered in addition to cropping and renewal.

**4.3.5** To reduce the possibility of future fractures in cargo hatch coamings the following details should be observed:

- (a) cut-outs and other discontinuities at top of the coaming should have rounded corners (preferably elliptical or circular in shape) (See **Example 8-b**). Any local reinforcement should be given a tapered transition in the longitudinal direction and the rate of taper should not exceed 1 in 3 (See **Example 6**).
- (b) cut-outs and drain holes are to be avoided in the hatch side coaming extension brackets. For fractured brackets, see **Examples 5**.

**4.3.6** For cargo hatch covers, fractures of a minor nature may be veed-out and welded. For more extensive fractures, the structure should be cropped and part renewed.

**4.3.7** For fractures at the end of bulwarks an attempt should be made to modify the design in order to reduce the stress concentration in connection with general cropping and renewal (See Example 18).

**4.4 Miscellaneous**

**4.4.1** Ancillary equipment such as cleats, rollers etc. on cargo hatch covers are to be renewed as necessary when damaged or corroded.

**No. 84**  
(cont)

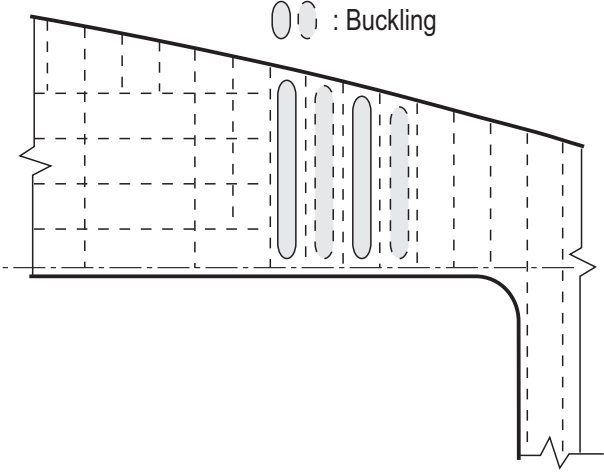
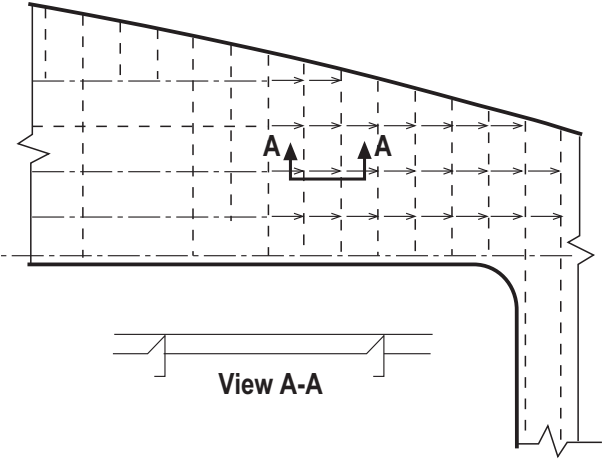
<b>CONTAINER SHIPS</b>		<b>Guidelines for Surveys, Assessment and Repair of Hull Structure</b>	
<b>Part 1</b>	<b>Cargo hold region</b>	<b>Example No. 1</b>	
<b>Area 1</b>	<b>Upper deck structure including passageways</b>		
<b>Detail of damage</b>	<b>Buckling of deck plating of transverse framing system</b>		
<b>Sketch of damage</b>		<b>Sketch of repair</b>	
			
<b>Notes on possible cause of damage</b>		<b>Notes on repairs</b>	
<ol style="list-style-type: none"> <li>Excessive compressive stress due to slamming or bow flare effect.</li> <li>Insufficient longitudinal stiffening of deck plating.</li> </ol>		<ol style="list-style-type: none"> <li>Buckled plating should be cropped and renewed. Longitudinal internal stiffeners should be provided. (Instead of longitudinal stiffeners, renewal by thicker deck plating can be accepted.)</li> <li>Stress concentration may occur at the end of sniped stiffener resulting in fatigue fracture. For locations where high cyclic stress may occur, appropriate connection such as lug-connection should be considered.</li> </ol>	

**No. 84**  
(cont)

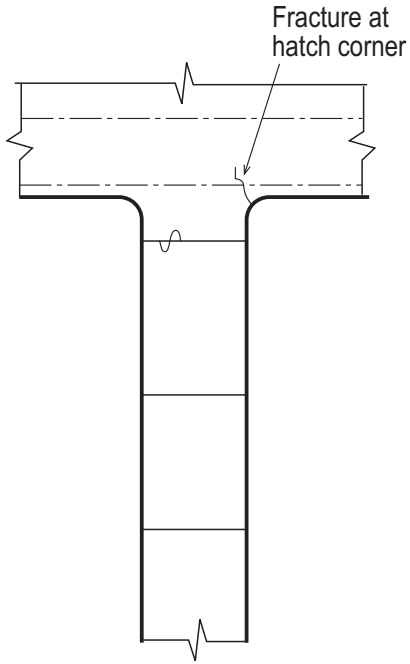
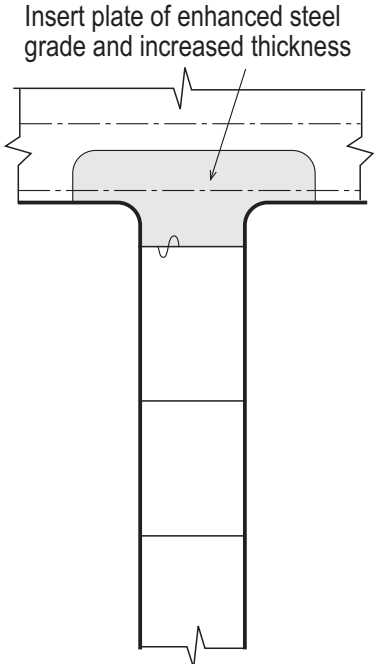
<b>CONTAINER SHIPS</b>		<b>Guidelines for Surveys, Assessment and Repair of Hull Structure</b>	
<b>Part 1</b>	<b>Cargo hold region</b>	<b>Example No. 2-a</b>	
<b>Area 1</b>	<b>Upper deck structure including passageways</b>		
<b>Detail of damage</b>	Fractures at main cargo hatch corner		
<b>Sketch of damage</b>		<b>Sketch of repair</b>	
			
<b>Notes on possible cause of damage</b>		<b>Notes on repairs</b>	
<p>1. Stress concentration at hatch corners, i.e. radius of corner.</p>		<p>1. The corner plating in way of the fracture is to be cropped and renewed. If stress concentration is primary cause, insert plate should be increased thickness, enhanced steel grade and/or improved geometry.</p> <p>Insert plate should be continued beyond the longitudinal and transverse extent of the hatch corner radius ellipse or parabola, and the butt welds to the adjacent deck plating should be located well clear of the butts in the hatch coaming.</p> <p>It is recommended that the edges of the insert plate and the butt welds connecting the insert plates to the surrounding deck plating be made smooth by grinding. In this respect caution should be taken to ensure that the micro grooves of the grinding are parallel to the plate edge.</p>	

**No. 84**  
(cont)

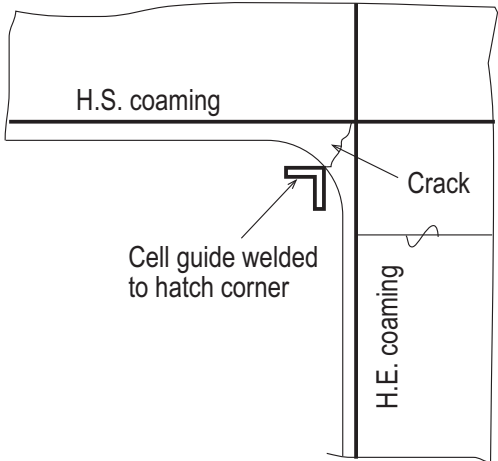
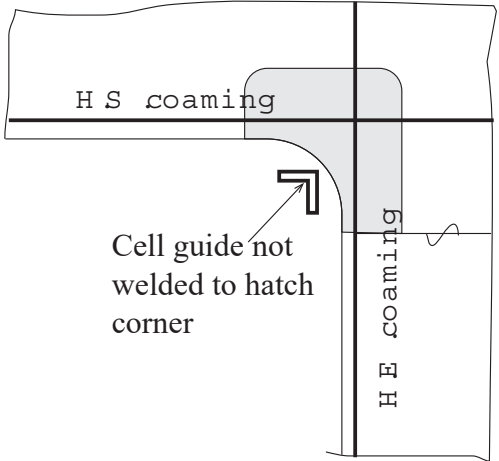
<b>CONTAINER SHIPS</b>	<b>Guidelines for Surveys, Assessment and Repair of Hull Structure</b>	
<b>Part 1</b>	<b>Cargo hold region</b>	<b>Example No. 2-b</b>
<b>Area 1</b>	<b>Upper deck structure including passageways</b>	
<b>Detail of damage</b>	Fractures at main cargo hatch corner initiated from welded joint of cell guide	
<p><b>Sketch of damage</b></p>  <p>The sketch shows a cross-section of the hatch corner. A horizontal line represents the H.S. coaming, and a vertical line represents the H.E. coaming. A cell guide is shown as a T-shaped structure welded to the corner. A crack is indicated by a jagged line at the junction of the cell guide and the H.S. coaming.</p>	<p><b>Sketch of repair</b></p>  <p>The sketch shows the same hatch corner as the damage sketch, but the cell guide is not welded to the H.S. coaming. Instead, it is shown as a separate component that is integrated into the hatch corner structure.</p>	
<p><b>Notes on possible cause of damage</b></p> <ol style="list-style-type: none"> <li>1. In addition to high stress of hatch corner welded connection of cell guide caused stress concentration.</li> </ol>	<p><b>Notes on repairs</b></p> <ol style="list-style-type: none"> <li>1. Fractured deck plating is to be cropped and renewed.</li> <li>2. Welding of cell guides to deck plating at hatch corner is to be avoided.</li> <li>3. Cell guide should be connected to ship structure below deck level.</li> <li>4. Alternatively an integration of the cell guide into the hatch corner could be considered.</li> </ol>	

**No. 84**  
(cont)

<b>CONTAINER SHIPS</b>		<b>Guidelines for Surveys, Assessment and Repair of Hull Structure</b>	
<b>Part 1</b>	<b>Cargo hold region</b>	<b>Example No. 2-c</b>	
<b>Area 1</b>	<b>Upper deck structure including passageways</b>		
<b>Detail of damage</b>	Fractures at main cargo hatch corner initiated at sniped end of stiffener		
<b>Sketch of damage</b>		<b>Sketch of repair</b>	
<b>Notes on possible cause of damage</b>		<b>Notes on repairs</b>	
<p>1. In addition to high stress at hatch corner sniped end of stiffener (for buckling) caused stress.</p>		<p>1. Fractured deck plating is to be cropped and renewed.</p> <p>2. Stiffener is to be removed. If necessary, thicker deck plating is to be considered.</p>	

**No. 84**  
(cont)

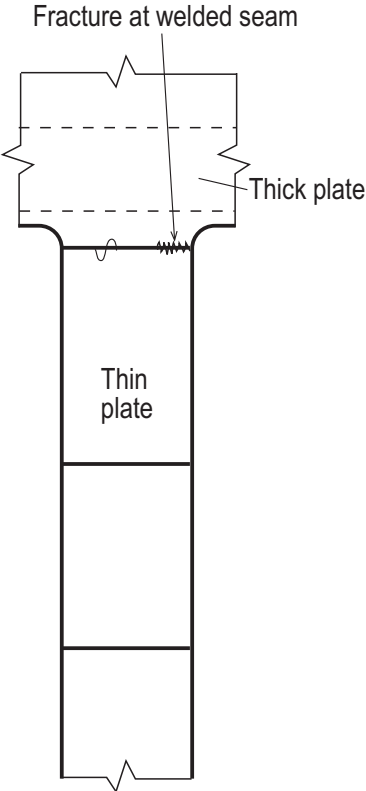
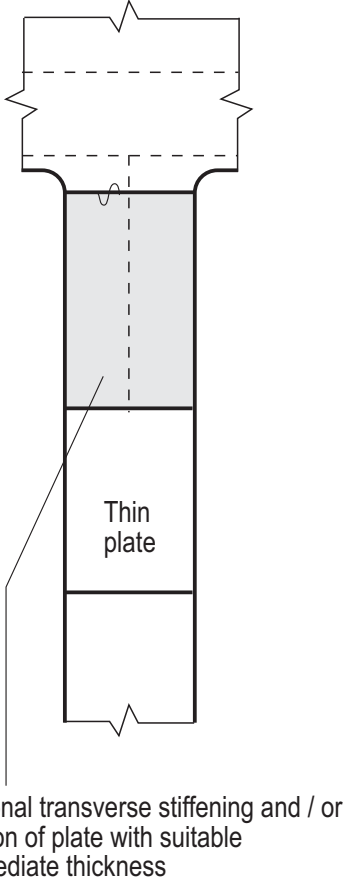
<b>CONTAINER SHIPS</b>		<b>Guidelines for Surveys, Assessment and Repair of Hull Structure</b>	
<b>Part 1</b>	<b>Cargo hold region</b>	<b>Example No. 3-a</b>	
<b>Area 1</b>	<b>Upper deck structure including passageways</b>		
<b>Detail of damage</b>	Fracture of welded seam between thick plate and thin plate at cross deck		
<b>Sketch of damage</b>		<b>Sketch of repair</b>	
			
<b>Notes on possible cause of damage</b>		<b>Notes on repairs</b>	
<ol style="list-style-type: none"> <li>1. Stress concentration created by abrupt change in deck plating thickness.</li> <li>2. In-plane bending in cross deck strip due to torsional (longitudinal) movements of ship sides.</li> <li>3. Welded seam not clear of tangent point of hatch corner.</li> </ol>		<ol style="list-style-type: none"> <li>1. Insert plate of intermediate thickness is recommended.</li> <li>2. Smooth transition between plates (beveling) should be considered.</li> </ol>	



**No. 84**  
(cont)

CONTAINER SHIPS		Guidelines for Surveys, Assessment and Repair of Hull Structure	
Part 1	Cargo hold region	Example No. 3-b	
Area 1	Upper deck structure including passageways		
<b>Detail of damage</b>		Plate buckling in thin plate near thick plate at cross deck	
<b>Sketch of damage</b>		<b>Sketch of repair</b>	
<b>Notes on possible cause of damage</b>		<b>Notes on repairs</b>	
<ol style="list-style-type: none"> <li>1. In-plane shear of cross deck strip due to torsional (longitudinal) deflection of ship sides, often in combination with corrosion.</li> <li>2. Insufficient transverse stiffening.</li> </ol>		<ol style="list-style-type: none"> <li>1. Transverse stiffeners extending from hatch sides towards centerline at least 10% of breadth of hatch, and/or increased plate thickness in the same area.</li> </ol>	

**No. 84**  
(cont)

<b>CONTAINER SHIPS</b>		<b>Guidelines for Surveys, Assessment and Repair of Hull Structure</b>	
<b>Part 1</b>	<b>Cargo hold region</b>	<b>Example No. 3-c</b>	
<b>Area 1</b>	<b>Upper deck structure including passageways</b>		
<b>Detail of damage</b>		Overall buckling of cross deck plating	
<b>Sketch of damage</b>		<b>Sketch of repair</b>	
<b>Notes on possible cause of damage</b>		<b>Notes on repairs</b>	
<ol style="list-style-type: none"> <li>1. Transverse compression of deck due to sea load.</li> <li>2. Insufficient transverse stiffening.</li> </ol>		<ol style="list-style-type: none"> <li>1. <b>Repair A</b> Plating of original thickness in combination with additional transverse stiffening.</li> <li>2. <b>Repair B</b> Insertion of plating of increased thickness.</li> </ol>	

**No. 84**  
(cont)

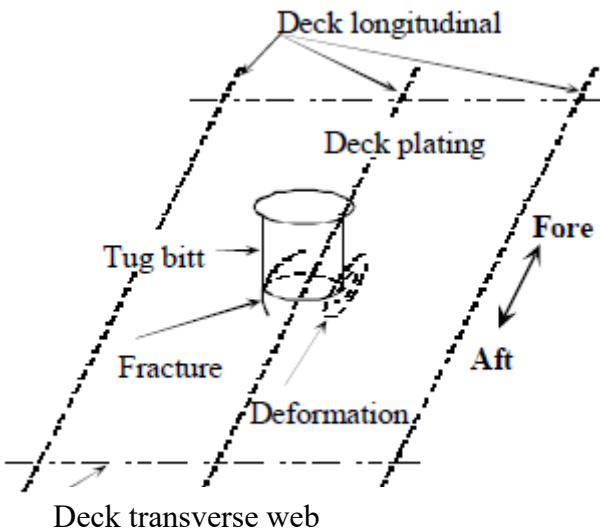
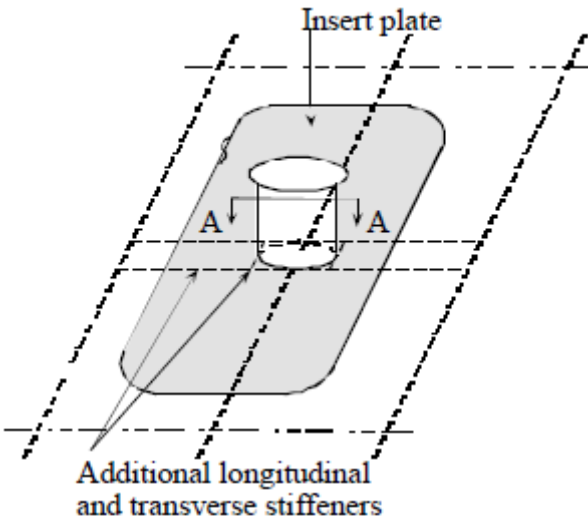
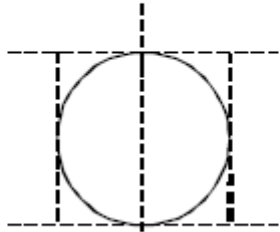
<b>CONTAINER SHIPS</b>		<b>Guidelines for Surveys, Assessment and Repair of Hull Structure</b>	
<b>Part 1</b>	<b>Cargo hold region</b>	<b>Example No. 3-d</b>	
<b>Area 1</b>	<b>Upper deck structure including passageways</b>		
<b>Detail of damage</b>	Deformed and fractured deck plating around tug bitt		
<b>Sketch of damage</b>			
<b>Sketch of repair</b>	  <p style="text-align: center;"><b>View A-A</b></p>		
<b>Notes on possible cause of damage</b>	<p>1. Insufficient strength</p>		
<b>Notes on repairs</b>	<p>1. Fractured/deformed deck plating should be cropped and part renewed.</p> <p>2.Reinforcement by stiffeners should be considered.</p>		

No. 84  
(cont)

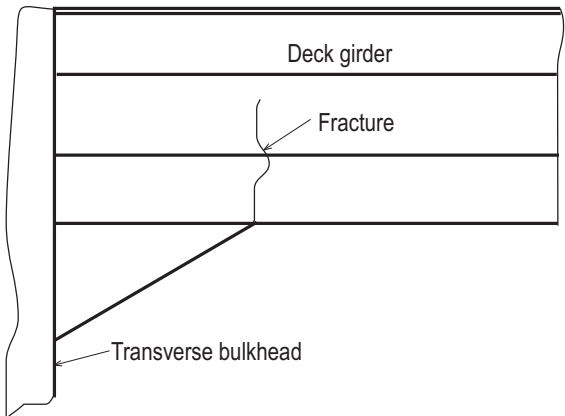
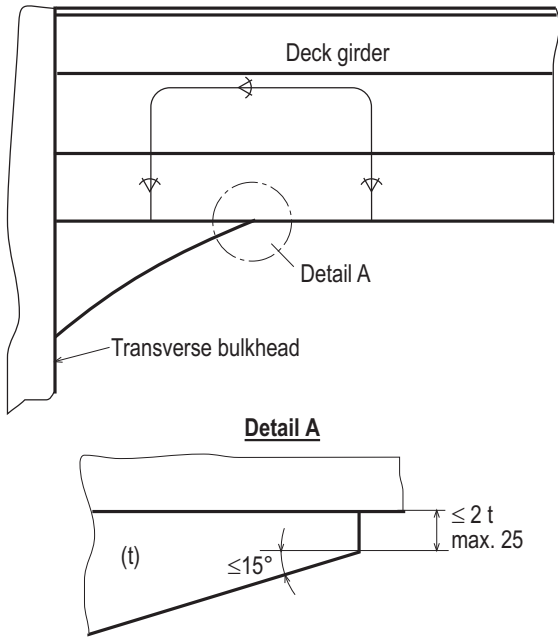
CONTAINER SHIPS		Guidelines for Surveys, Assessment and Repair of Hull Structure	
Part 1	Cargo hold region	Example No. 4	
Area 1	Upper deck structure including passageways		
<b>Detail of damage</b>		Fracture in longitudinal deck girder initiated at bracket toe	
<b>Sketch of damage</b>		<b>Sketch of repair</b>	
 <p>Labels: Deck girder, Fracture, Transverse bulkhead</p>		 <p>Labels: Deck girder, Transverse bulkhead, Detail A</p> <p><b>Detail A</b></p> <p>(t) <math>\leq 15^\circ</math> <math>\leq 2t</math> max. 25</p>	
<b>Notes on possible cause of damage</b>		<b>Notes on repairs</b>	
<ol style="list-style-type: none"> <li>1. Stress concentration at the toe of deck girder bracket</li> </ol>		<ol style="list-style-type: none"> <li>1. Fractured plating should be cropped and part renewed.</li> <li>2. Modified soft bracket should be considered.</li> </ol>	

# No. 84

(cont)

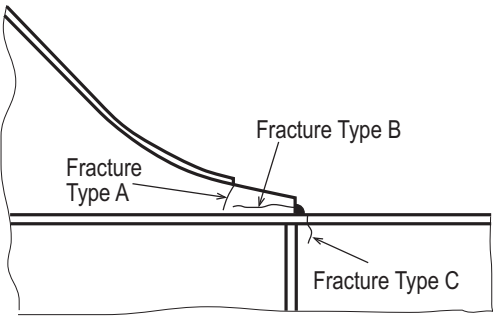
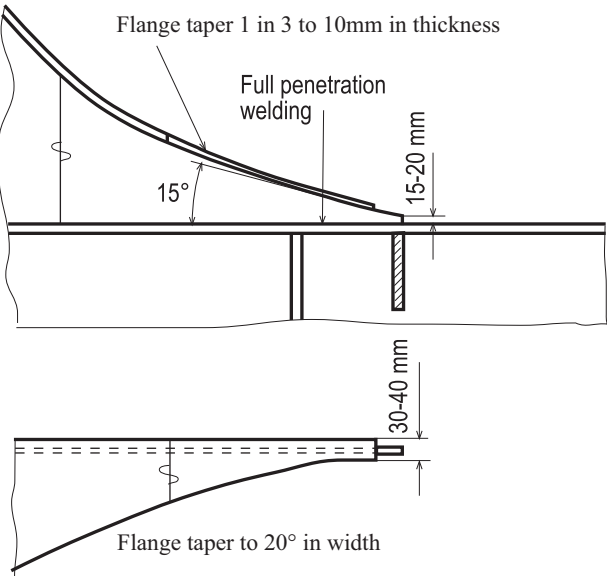
CONTAINER SHIPS		Guidelines for Surveys, Assessment and Repair of Hull Structure	
Part 1	Cargo hold region	Example No. 5	
Area 1	Upper deck structure including passageways	5	
Detail of damage	Fractures in continuous longitudinal hatch coaming extension bracket		
Sketch of damage	Sketch of repair		
			
Notes on possible cause of damage	Notes on repairs		
<ol style="list-style-type: none"> <li>1. Flange force at the end of the flange too high due to insufficient tapering (<b>Fracture Type A</b>, propagating in the web).</li> <li>2. Shear force in the web plate too high due to insufficient reduction of the web height at the end (<b>Fracture Type B</b>, propagating in the web at the undercut or HAZ of the fillet weld).</li> <li>3. Insufficient support of the extension bracket below the deck (<b>Fracture Type C</b>, starting from undercut or HAZ of the fillet weld and propagating in the deck plating).</li> </ol>	<ol style="list-style-type: none"> <li>1. Extend the extension bracket as long as possible to arrange a gradual transition.</li> <li>2. Reduce the web height at the end of the bracket; in case of high stress areas grind smooth the transition to the deck plating welding.</li> <li>3. Reduce the cross sectional area of the flange at the end as far as possible. Such as flange taper 1 in 3 to 10mm in thickness and taper 20° in width.</li> <li>4. Provide longitudinal structure in way of the web of the extension bracket to the next transverse structure or provide a new transverse structure.</li> <li>5. The web plate to be cropped and renewed with new plate which increase in thickness of 30-50%, if it does not become excessive</li> </ol>		

No. 84  
(cont)

<b>CONTAINER SHIPS</b>		<b>Guidelines for Surveys, Assessment and Repair of Hull Structure</b>	
<b>Part 1</b>	<b>Cargo hold region</b>	<b>Example No. 6</b>	
<b>Area 1</b>	<b>Upper deck structure including passageways</b>		
<b>Detail of damage</b>	<b>Fractures in hatch side coaming</b>		
<b>Sketch of damage</b>		<b>Sketch of repair</b>	
<b>Notes on possible cause of damage</b>		<b>Notes on repairs</b>	
<p>1. Additional stress caused by bending moment due to the difference of thickness.</p>		<p>1. Fractured plating is to be cropped and renewed.</p> <p>2. Insert of plate of intermediate thickness is to be considered.</p>	

**No. 84**  
(cont)

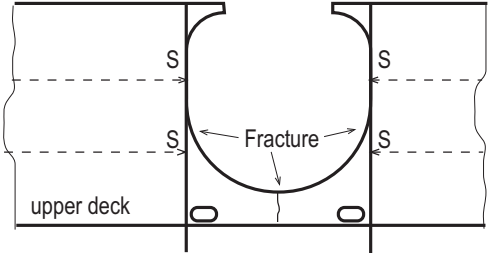
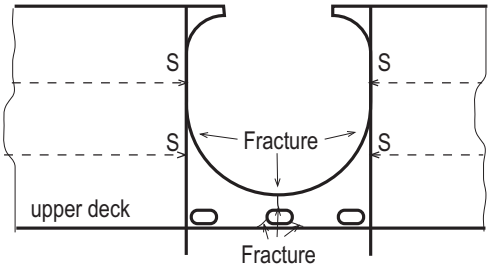
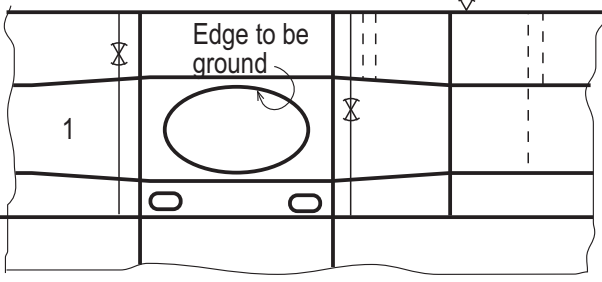
<b>CONTAINER SHIPS</b>		<b>Guidelines for Surveys, Assessment and Repair of Hull Structure</b>	
<b>Part 1</b>	<b>Cargo hold region</b>	<b>Example No. 7</b>	
<b>Area 1</b>	<b>Upper deck structure including passageways</b>		
<b>Detail of damage</b>		Fracture in access hole of longitudinal hatch coaming	
<b>Sketch of damage</b>		<b>Sketch of repair</b>	
 <p style="text-align: center;"><b>Sketch No. 1 a</b></p>  <p style="text-align: center;"><b>Sketch No. 1 b</b></p>			
<b>Notes on possible cause of damage</b>		<b>Notes on repairs</b>	
<p>1. Coincidence of maximum of increased stress due to the reduction of the hatch coaming with the metallurgical notches due to the welding seams in web and flat bar located at the same position.</p>		<p>1. Hatch coaming to be continuous.                  2. Access opening to be provided.                  3. Drain holes to be elliptical and located above fillet weld to deck.                  4. Hatch coaming stiffeners of same material as coaming</p>	

**No. 84**  
(cont)

<b>CONTAINER SHIPS</b>		<b>Guidelines for Surveys, Assessment and Repair of Hull Structure</b>	
<b>Part 1</b>	<b>Cargo hold region</b>	<b>Example No. 8-a</b>	
<b>Area 1</b>	<b>Upper deck structure including passageways</b>		
<b>Detail of damage</b>		Fractures in hatch coaming top plate at the termination of rail for hatch cover	
<b>Sketch of damage</b>		<b>Sketch of repair</b>	
<b>Notes on possible cause of damage</b>		<b>Notes on repairs</b>	
<p>1. Stress concentration at the termination of the rail for hatch cover due to poor design.</p>		<p>1. Fractured plate is to be cropped and part renewed.</p> <p>2. Thicker insert plate and/or reinforcement by additional stiffener under the top plate should be considered. Also refer to <b>Example 9-b</b>.</p>	





**No. 84**  
(cont)

<b>CONTAINER SHIP</b>		<b>Guidelines for Surveys, Assessment and Repair of Hull Structure</b>	
<b>Part 1</b>	<b>Cargo hold region</b>	<b>Example No.8-b 8-b</b>	
<b>Area 1</b>	<b>Upper deck structure including passageways</b>		
<b>Detail of damage</b>		Fractures in hatch coaming top plate at the termination of rail for hatch cover	
<p><b>Sketch of damage</b></p>		<p><b>Sketch of repair</b></p>	
<p><b>Notes on possible cause of damage</b></p> <p>1. Stress concentration at the termination of the rail for hatch cover due to poor design of opening.</p>		<p><b>Notes on repairs</b></p> <p>1. Fractured plate is to be cropped and part renewed.</p> <p>2. Thicker insert plate and/or reduction of stress concentration adopting large radius should be considered. Or cut-out in the rail and detachment of the welds as shown in the above drawing should be considered in order to reduce the stress of the corner of the opening.</p>	

**No. 84**  
(cont)

<b>CONTAINER SHIP</b>		<b>Guidelines for Surveys, Assessment and Repair of Hull Structure</b>	
<b>Part 1</b>	<b>Cargo hold region</b>	<b>Example No. 9</b>	
<b>Area 1</b>	<b>Upper deck structure including passageways</b>		
<b>Detail of damage</b>	Fractures in hatch coaming top plate initiated from butt weld of compression bar		
<p><b>Sketch of damage</b></p> <p><b>Detail</b></p>		<p><b>Sketch of repair</b></p>	
<p><b>Notes on possible cause of damage</b></p> <ol style="list-style-type: none"> <li>1. Heavy weather</li> <li>2. Insufficient preparation of weld of compression bar and/or rail (Although the compression bar and rail are not longitudinal strength members, they are subject to the same longitudinal stress as longitudinal members)</li> <li>3. Fracture may initiate from insufficient penetration of weld of rail for hatch cover.</li> </ol>		<p><b>Notes on repairs</b></p> <ol style="list-style-type: none"> <li>1. Loading condition of the ship and proper welding procedure should be carefully considered.</li> <li>2. Fractured structure is to be cropped and renewed if considered necessary. (Small fracture may be veed-out and rewelded.)</li> <li>3. Full penetration welding should be applied to the butt weld of compression bar and rail.</li> </ol>	

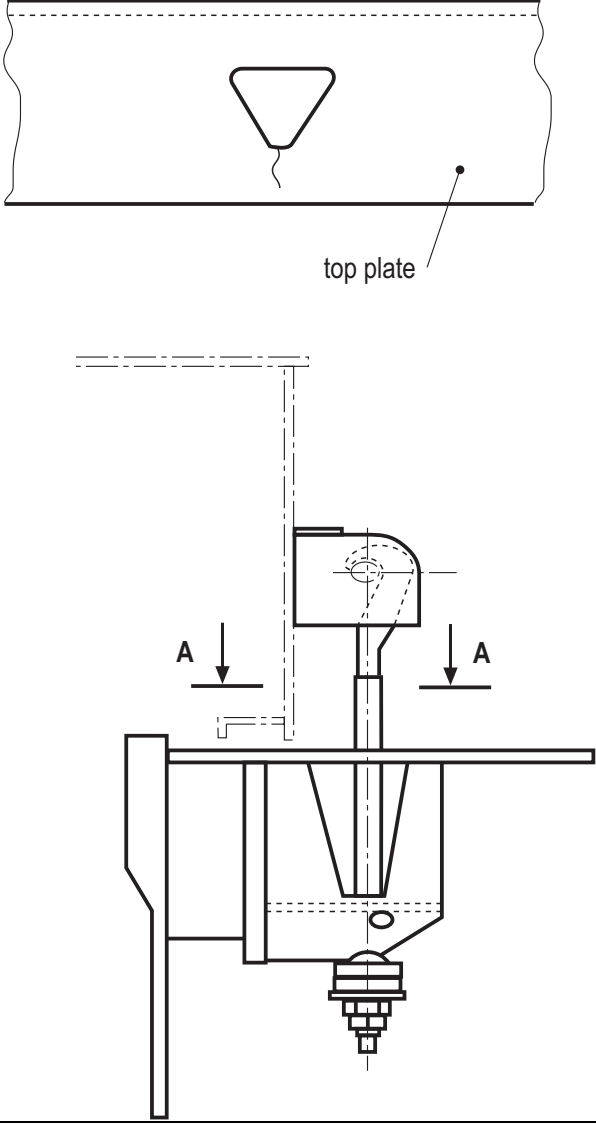
**No. 84**  
(cont)

<b>CONTAINER SHIPS</b>		<b>Guidelines for Surveys, Assessment and Repair of Hull Structure</b>	
<b>Part 1</b>	<b>Cargo hold region</b>	<b>Example No. 10</b>	
<b>Area 1</b>	<b>Upper deck structure including passageways</b>		
<b>Detail of damage</b>	Fracture in hatch coaming top plate in way of i.w.o. quick acting cleat		
<b>Sketch of damage</b>		<b>Sketch of repair</b>	
<p style="text-align: center;"><u>Section A-A</u></p> 			
<b>Notes on possible cause of damage</b>		<b>Notes on repairs</b>	
<ol style="list-style-type: none"> <li>1. Stress concentration at hole</li> <li>2. Inadequate design</li> <li>3. Poor workmanship</li> </ol>		<ol style="list-style-type: none"> <li>1. Damaged area to be cropped and renewed.</li> <li>2. Elliptical hole to be provided for the quick acting cleat</li> </ol>	

**No. 84**  
(cont)

<b>CONTAINER SHIPS</b>		<b>Guidelines for Surveys, Assessment and Repair of Hull Structure</b>	
<b>Part 1</b>	<b>Cargo hold region</b>	<b>Example No. 11</b>	
<b>Area 1</b>	<b>Upper deck structure including passageways</b>		
<b>Detail of damage</b>		Fractures in hatch coaming top plate around resting pad	
<b>Sketch of damage</b>		<b>Sketch of repair</b>	
<p><b>Fracture Type A:</b> Starting in way of the undercut or HAZ of the transverse fillet weld and propagating in the top plating.</p> <p><b>Fracture Type B:</b> Starting in way of the undercut or HAZ of the longitudinal fillet weld and propagating in the top plating.</p> <p><b>Fracture Type C:</b> Starting and propagating in fillet weld</p>		<p><b>Repair for "Fracture Type A"</b> Note: Cut, if the pad has enough area</p> <p><b>Repair for "Fracture Type B"</b></p> <p><b>View A-A</b></p>	
<b>Notes on possible cause of damage</b>		<b>Notes on repairs</b>	
<ol style="list-style-type: none"> <li><b>Fracture Type A:</b> Inappropriate transition from the hatch coaming top plating to the resting pad in respect to longitudinal stresses.</li> <li><b>Fracture Type B:</b> Insufficient support of the resting pad below the top plating.</li> <li><b>Fracture Type C:</b> Insufficient throat thickness of the fillet weld in relation to the vertical forces.</li> </ol>		<ol style="list-style-type: none"> <li><b>Fracture Type A:</b> Modification of the transverse fillet weld according to the sketch; in some cases smoothing of the transition by grinding is acceptable.</li> <li><b>Fracture Type B:</b> Strengthening of the structures below the top plating according to the sketch.</li> <li><b>Fracture Type C:</b> Increasing the throat thickness corresponding to the acting vertical forces.</li> </ol>	

No.  
84

(cont)

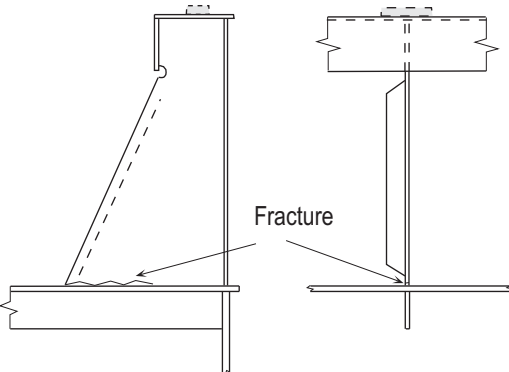
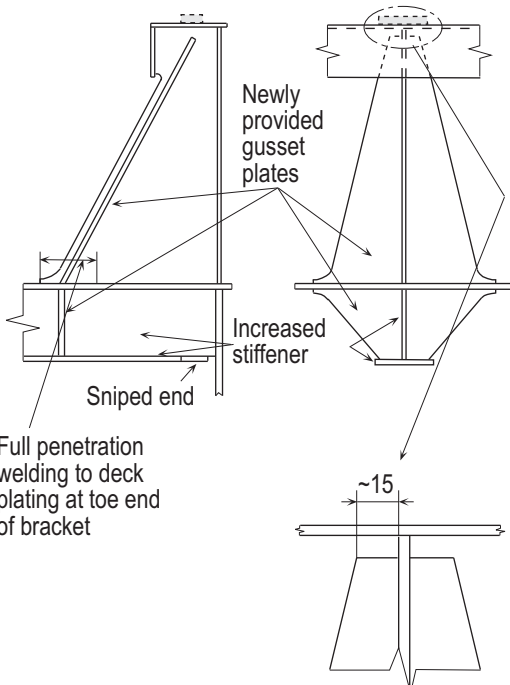
CONTAINER SHIPS		Guidelines for Surveys, Assessment and Repair of Hull Structure	
Part 1	Cargo hold region	Example No. 12-a	
Area 1	Upper deck structure including passageways		
Detail of damage	Fractures in web of transverse hatch coaming stay		
<b>Sketch of damage</b> 		<b>Sketch of repair</b> 	
<b>Notes on possible cause of damage</b> <ol style="list-style-type: none"> <li>Insufficient consideration of the horizontal friction forces in way of the resting pads for hatch cover.</li> </ol>		<b>Notes on repairs</b> <ol style="list-style-type: none"> <li>Modification of the design of the hatch coaming stay.</li> <li>Full penetration welding between gusset plates and deck plating.</li> <li>Strengthening and continuation of the structure below the deck.</li> <li>Use pads with smaller coefficient of friction.</li> </ol>	

**No. 84**  
(cont)

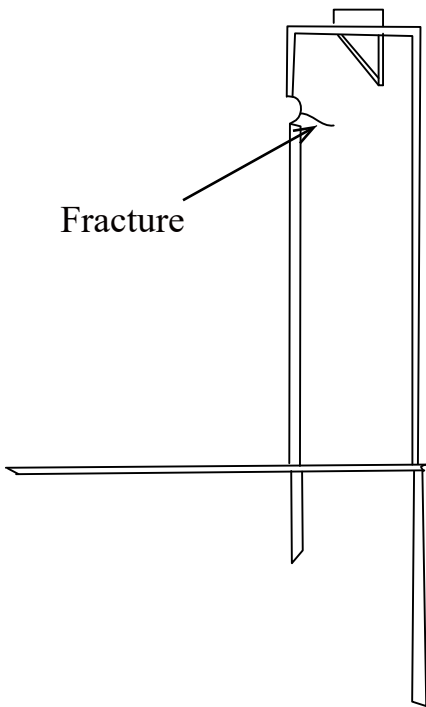
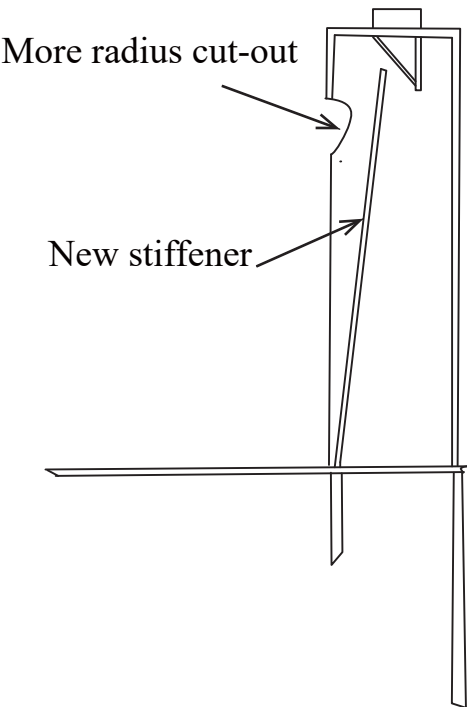
<b>CONTAINER SHIPS</b>		<b>Guidelines for Surveys, Assessment and Repair of Hull Structure</b>	
<b>Part 1</b>	<b>Cargo hold region</b>	<b>Example No.</b>	
<b>Area 1</b>	<b>Upper deck structure including passageways</b>	<b>12-b</b>	
<b>Detail of damage</b>		Fractures in web of transverse hatch coaming stay	
<b>Sketch of damage</b>		<b>Sketch of repair</b>	
			
<b>Notes on possible cause of damage</b>		<b>Notes on repairs</b>	
<p>1. Insufficient consideration of the horizontal friction forces in way of the resting pads for hatch cover.</p>		<p>1. Expanded radius of the cut-out of the upper part of stay.</p> <p>2. Fixing a vertical stiffener as long as possible.</p> <p>3. Grinding of the radius cut-out.</p>	

No.  
84

(cont)

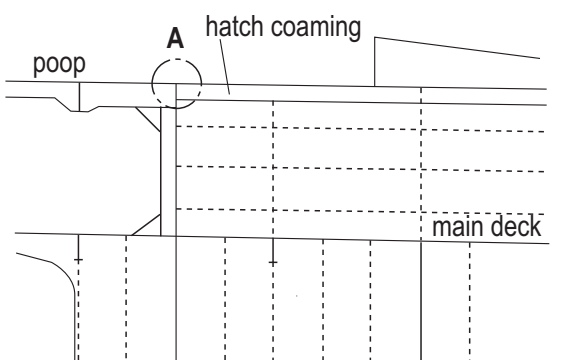
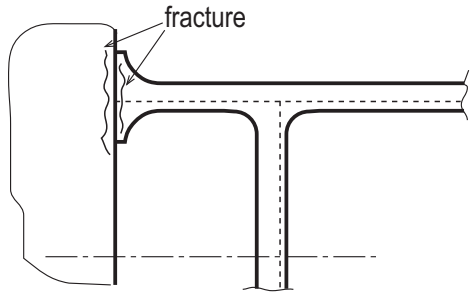
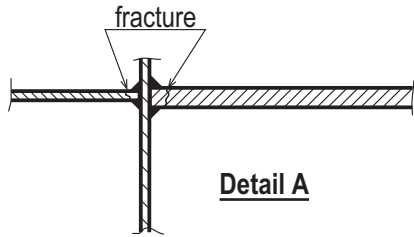
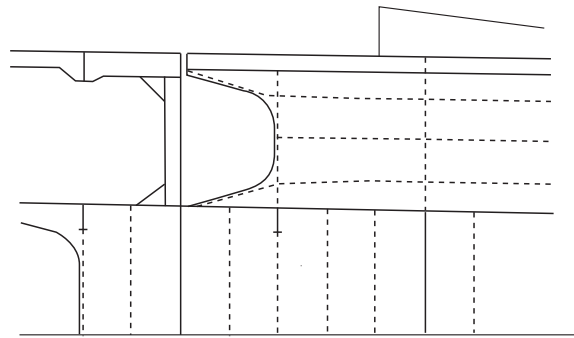
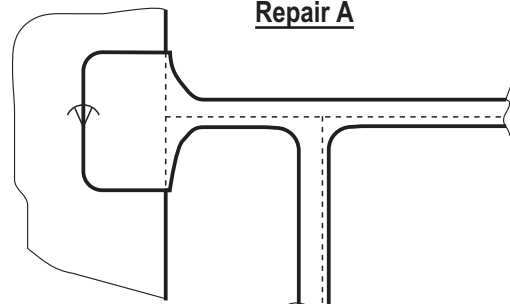
CONTAINER SHIPS		Guidelines for Surveys, Assessment and Repair of Hull Structure	
Part 1	Cargo hold region	Example No. 13	
Area 1	Upper deck structure including passageways	13	
Detail of damage	Fractures in the connection of the web of transverse hatch coaming stay		
Sketch of damage		Sketch of repair	
  		<p style="text-align: center;"><u>Repair B</u></p>  <p style="text-align: center;"><u>Repair A</u></p> 	
<p><b>Notes on possible cause of damage</b></p> <ol style="list-style-type: none"> <li>Insufficient transfer of forces from hatch coaming top plate into poop deck plating by cruciform connection.</li> </ol>		<p><b>Notes on repairs</b></p> <ol style="list-style-type: none"> <li>Continuation of hatch coaming top plate by inserting thick plate into the thin poop deck plating (chamfer 1:5) see Repair A.</li> <li>Cutting of the connection between longitudinal hatch coaming and poop in the case that the strength requirements are satisfactory (see Repair B).</li> </ol>	

**No. 84**  
(cont)

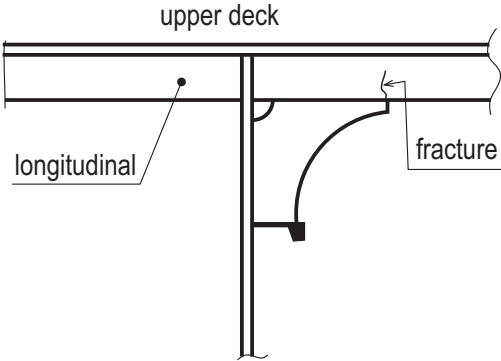
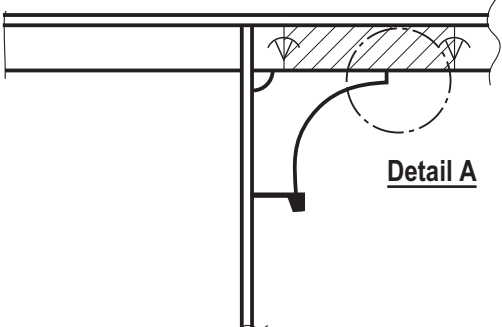
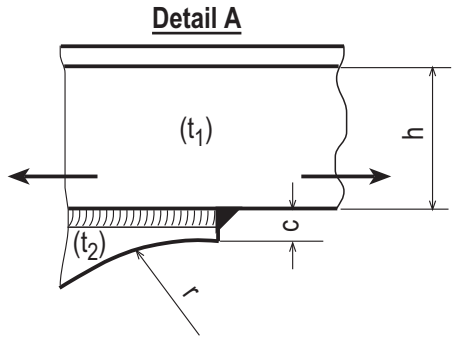
<b>CONTAINER SHIPS</b>		<b>Guidelines for Surveys, Assessment and Repair of Hull Structure</b>	
<b>Part 1</b>	<b>Cargo hold region</b>	<b>Example No. 14</b>	
<b>Area 1</b>	<b>Upper deck structure including passageways</b>		
<b>Detail of damage</b>	<b>Fracture in Deck Longitudinal</b>		
<b>Sketch of damage</b>		<b>Sketch of repair</b>	
 <p>upper deck longitudinal fracture</p>		 <p><u>Detail A</u></p>  <p><u>Detail A</u></p> <p>(t<sub>1</sub>) (t<sub>2</sub>) r c</p> <p><math>c \leq 2 t_2</math> max. 25 mm <math>r \geq 0,5 h</math></p>	
<b>Notes on possible cause of damage</b>		<b>Notes on repairs</b>	
<ol style="list-style-type: none"> <li>1. Stress concentration at bracket toe</li> <li>2. Bracket toe too high</li> <li>3. Poor workmanship</li> </ol>		<ol style="list-style-type: none"> <li>1. Damaged area to be cropped and renewed</li> <li>2. New bracket with soft toe to be added.</li> </ol>	



**No. 84**  
(cont)

<b>CONTAINER SHIPS</b>		<b>Guidelines for Surveys, Assessment and Repair of Hull Structure</b>	
<b>Part 1</b>	<b>Cargo hold region</b>	<b>Example No. 15</b>	
<b>Area 1</b>	<b>Upper deck structure including passageways</b>		
<b>Detail of damage</b>		Fractures in a hatch cover girder	
<b>Sketch of damage</b>		<b>Sketch of repair</b>	
<p>The sketch of damage shows a side view of a hatch cover girder. A vertical arrow labeled <math>F_v</math> Container Load points down on the top flange. A horizontal arrow labeled <math>F_H = \mu \cdot F_v</math> Frictional Forces points left from the bottom flange. A dashed circle indicates a fracture in the top flange. Below this is a cross-section labeled <b>Detail A</b> showing a flange with thickness <math>t_1</math> on the left and <math>t_2</math> on the right, with a fracture in the middle. The equation <math>t_2 \sim 4 \cdot t_1</math> is written below the cross-section.</p>		<p>The sketch of repair shows a cross-section of the hatch cover girder. The damaged area has been removed and replaced with a repair. Two triangular shapes labeled 'insert' are shown at the bottom of the repair area, indicating the repair method.</p>	
<b>Notes on possible cause of damage</b>		<b>Notes on repairs</b>	
<ol style="list-style-type: none"> <li>1. Stress concentration</li> <li>2. Incorrect tapering leads to additional flange bending</li> <li>3. Poor workmanship</li> </ol>		<ol style="list-style-type: none"> <li>1. Damaged area to be cropped off and renewed</li> <li>2. Flange with intermediate thickness to be fitted.</li> </ol>	

**No. 84**  
(cont)

<b>CONTAINER SHIPS</b>		<b>Guidelines for Surveys, Assessment and Repair of Hull Structure</b>	
<b>Part 1</b>	<b>Cargo hold region</b>	<b>Example No. 16</b>	
<b>Area 1</b>	<b>Upper deck structure including passageways</b>		
<b>Detail of damage</b>		Fractures in deck girder	
<b>Sketch of damage</b>		<b>Sketch of repair</b>	
<p>The sketch shows a cross-section of a deck girder. On the left, a vertical dashed line represents the 'Transverse bulkhead/hatch end coaming'. The deck girder is shown as a U-shaped profile. A horizontal dashed line indicates the centerline. An arrow points to a break in the bottom flange of the deck girder, labeled 'Fracture'. Below the profile is the label '(Profile)'. To the right is a vertical section view of the deck girder, labeled '(Section)', showing the internal structure and the location of the fracture.</p>		<p>The sketch shows the same deck girder profile and section as in the damage sketch. The fractured ends of the bottom flange have been removed. A hatched rectangular area, labeled 'Insert plate', is shown being fitted into the gap at the end of the deck girder. The label 'Insert plate' has a line pointing to this hatched area.</p>	
<b>Notes on possible cause of damage</b>		<b>Notes on repairs</b>	
<ol style="list-style-type: none"> <li>1. Insufficient rigidity at the end of deck girder against bending and torsion</li> </ol>		<ol style="list-style-type: none"> <li>1. Fractured parts are to be cropped and partially renewed.</li> <li>2. Insert plate at the end of deck girder as shown in sketch of repair.</li> </ol>	

**No. 84**  
(cont)

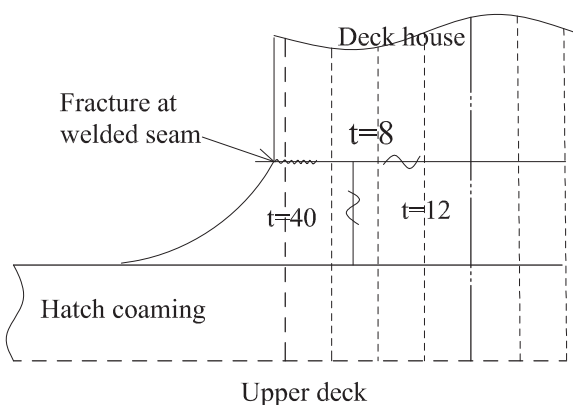
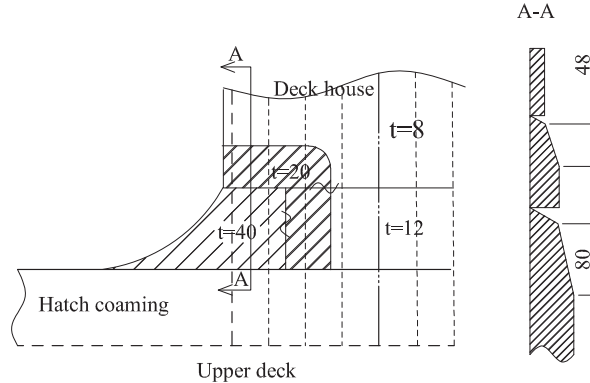
<b>CONTAINER SHIPS</b>		<b>Guidelines for Surveys, Assessment and Repair of Hull Structure</b>	
<b>Part 1</b>	<b>Cargo hold region</b>	<b>Example No. 17</b>	
<b>Area 1</b>	<b>Upper deck structure including passageways</b>		
<b>Detail of damage</b>	Fractures in the connections between hatch coaming and bulkhead of deck house		
<b>Sketch of damage</b>		<b>Sketch of repair</b>	
 <p>Fracture at welded seam</p> <p>Deck house</p> <p>Hatch coaming</p> <p>Upper deck</p> <p><math>t=40</math></p> <p><math>t=8</math></p> <p><math>t=12</math></p>		 <p>Deck house</p> <p>Hatch coaming</p> <p>Upper deck</p> <p><math>t=8</math></p> <p><math>t=20</math></p> <p><math>t=40</math></p> <p><math>t=12</math></p> <p>A-A</p> <p>48</p> <p>80</p>	
<b>Notes on possible cause of damage</b>		<b>Notes on repairs</b>	
<ol style="list-style-type: none"> <li>1. Stress concentration at the welding seam between plates with great differences of thickness.</li> </ol>		<ol style="list-style-type: none"> <li>1. Inserting plates with medium thickness between the plates with great differences of thickness.</li> <li>2. The plate to be tapered from thick plate to thin one</li> </ol>	

**No. 84**  
(cont)

CONTAINER SHIPS		Guidelines for Surveys, Assessment and Repair of Hull Structure	
Part 1	Cargo hold region	Example No. 18	
Area 1	Upper deck structure including passageways		
<b>Detail of damage</b>		Fracture in deck plating at the pilot ladder access of bulwarks	
<b>Sketch of damage</b>		<b>Sketch of repair</b>	
<b>Notes on possible cause of damage</b>		<b>Notes on repairs</b>	
<ol style="list-style-type: none"> <li>1. Stress concentration at the termination of bulwarks.</li> </ol>		<ol style="list-style-type: none"> <li>1. Fractured deck plating should be cropped and part renewed.</li> <li>2. Reduction of stress concentration should be considered. When repairing the fracture in the gusset plate consider replacing the existing gusset plate with a softer one and extend the pad plate as appropriate. Additional under deck stiffening should be considered to address the fracture in the deck plating.</li> </ol>	

---

**No. 84**      **Area 2 Side structure including side tanks****84**  
(cont)**Contents**

- 1      General**
  
- 2      What to look for – Cargo hold inspection**
  - 2.1    Material wastage**
  - 2.2    Deformations**
  - 2.3    Fractures**
  
- 3      What to look for Side tank inspection**
  - 3.1    Material wastage**
  - 3.2    Deformations**
  - 3.3    Fractures**
  
- 4      What to look for – External inspection**
  - 4.1    Material wastage**
  - 4.2    Deformations**
  - 4.3    Fractures**
  
- 5      General comments on repair**
  - 5.1    Material wastage**
  - 5.2    Deformations**
  - 5.3    Fractures**

**No.**  
**84**  
(cont)

**Examples of structural detail failures and repairs – Area 2**

Example No.	Title
1	Fractures in side shell frame at lower bracket
2-a	Fractures in side shell frame/lower bracket and side shell plating near tank top
2-b	Adverse effect of corrosion on the frame of forward hold
3-a	Buckling of side structure in way of side tank / passage way
3-b	Buckling of side structure in way of fender
4-a	Fracture and buckling in way of a cut-out for the passage of a longitudinal through a transverse web
4-b	Fracture at the connection of side shell longitudinal to transverse web
4-c	Fracture at the connection of side shell longitudinal to transverse web
4-d	Fracture at the connection of side shell longitudinal to transverse bulkhead
5	Fractures in side shell plating / longitudinal bulkhead plating at the corner of drain hole in longitudinal
6	Fractures in side wall of stringer deck (raised tank) at the connection of longitudinals to web of transverses
7	Fractures at the termination of stringer deck (raised tank)
8	Fracture in stringer deck in way of container sockets
9	Fracture in side longitudinal in way of side tank

**No.  
84**  
(cont)**1 General**

**1.1** In general, container ships have double hull side structure in the cargo hold area. The double hull is used as deep tanks, i.e. ballast tanks, heeling tanks or fuel oil tanks. In most cases, the upper part of the double hull is used as a passageway. Smaller container ships (and the foremost cargo hold in the case of larger container ships) may have a single side structure, at least in the upper part. Stringer decks (raised tanks) may be arranged in the foremost and aft cargo holds to provide additional space for container stacks.

**1.2** In addition to contributing to the shear strength of the hull girder, the side structure forms the external boundary of a cargo hold and is naturally the first line of defence against ingress or leakage of sea water when the ship's hull is subjected to wave and other dynamic loading in heavy weather. The integrity of the side structure is of prime importance to the safety of the ship and this warrants very careful attention during survey and inspection.

**1.3** The ship side structure is prone to damage caused by contact with the quay during berthing and impacts of cargo and cargo handling equipment during loading and unloading operations.

In longitudinally stiffened areas the side shell is more prone to damage due to action of fenders and tugs. A careful positioning of reinforced parts of the side shell structure in these areas, using the service experience of the owner, can reduce any damage.

**1.4** In some cases cell guides are fitted at the longitudinal bulkheads in order to guide containers during loading and unloading as well as to support the containers during the voyage.

**1.5** The structure in the transition regions at the fore and aft ends of the ship are subject to stress concentrations due to structural discontinuities. The side shell plating in the transition regions is also subject to panting. The lack of continuity of the longitudinal structure, and the increased slenderness and flexibility of the side structure, makes the structure at the transition regions more prone to fracture damage.

**2 What to look for – Cargo hold inspection****2.1 Material wastage**

**2.1.1** Material wastage is not a typical problem of the side structure of container vessels. However the side shell frames of the single side skin area, which can be found in the foremost cargo hold, may be weakened by loss of thickness although diminution and deformations may not be apparent. Inspection should be made after the removal of any scale or rust deposit. Thickness measurements may be necessary, in case the corrosion is smooth and uniform, to determine the condition of the structure.

**2.1.2** Wastage and possible grooving of the framing in the forward/aft hold, where side shell plating is oblique to frames, may result in fracture and buckling of the shell plating as shown in **Example 2-a/b**.

**2.2 Deformations**

**2.2.1** The side shell plating in the foremost part of the cargo hold region is subject to panting, particularly in the case of a large bow flare.

**2.2.2** Both the side shell plating and the internal structure can be found distorted forward and aft of tug push points, especially on ships with a longitudinal framing system.

**No.  
84**  
(cont)

**2.2.3** Cell guides and their connections to the side structure can be found deformed or distorted due to mishandling during container stowage.

### **2.3 Fractures**

**2.3.1** Fractures can be found in way of cutouts for passage of longitudinals through transverse web frames. In smaller vessels with a transverse framing system, fractures are more evident at the toes of the upper and lower bracket(s) or at the connections between brackets and frames. In both cases the fractures may be attributed to stress concentrations and stress variations created, in the main, by loads from the seaway. The stress concentrations can also be a result of poor detail design and/or bad workmanship. Localized fatigue fracturing, possibly in association with localized corrosion, may be difficult to detect and those areas should receive close attention during periodical surveys.

**2.3.2** The transition regions e.g. the ends of raised stringer decks or continuation brackets at collision bulkhead and engine room forward bulkhead are subject to stress concentrations due to structural discontinuities. The lack of continuity of the longitudinal structure can result in damage.

## **3 What to look for – Side tank inspection**

### **3.1 Material wastage**

**3.1.1** Tanks are susceptible to corrosion and wastage of the internal structure, particularly in ageing ships. Coatings, if applied and properly maintained, serve as an indication as to whether the structure remains in satisfactory condition and highlights any structural defects.

**3.1.2** The rate and extent of corrosion depends on the environmental conditions and protective measures employed, such as coating. The following structures are generally susceptible to corrosion.

- a) Structure in corrosive environment:
  - Transverse bulkhead adjacent to heated fuel oil tank
  - Lowest part of tank plating
- (b) Structure subject to high stress:
  - Connection of side longitudinal to transverse web frame
- (c) Areas susceptible to coating breakdown:
  - Back side of longitudinal face plate
  - Welded joint
  - Edge of access opening
- (d) Areas subjected to poor drainage:
  - Web of sloping longitudinals
  - Web of T-bar longitudinals
  - Stringer Deck



**No.  
84**  
(cont)**3.2 Deformations**

**3.2.1** Deformation of structure may be caused by contact (with the quay side, fenders, tugs, ice, touching underwater objects, etc.), collision, mishandling of cargo and high stress. Attention should be paid to any structure subjected to high stress.

**3.3 Fractures**

**3.3.1** Attention should be paid to the following areas during inspection for fracture damage: Areas subjected to stress concentration and dynamic wave loading:

- Connection of the longitudinals to transverse web frames.
- Connection of side longitudinal to watertight bulkhead.
- Connection of side longitudinal to transverse web frame.

**3.3.2** The termination of the following structural member at the collision bulkhead or engine room forward bulkhead is prone to fracture damage due to discontinuity of the structure:

- Longitudinal bulkhead
- Stringer decks

**4 What to look for – External inspection****4.1 Material wastage**

**4.1.1** The general condition with regard to wastage of the ship's sides may be observed by visual inspection from the quayside of the area above the waterline. Special attention should be paid to areas where the painting has deteriorated.

**4.2 Deformations**

**4.2.1** The side shell should be carefully inspected with respect to possible deformations. The side shell below the water-line can usually only be inspected when the ship is dry docked. Therefore special attention with respect to possible deformations should be paid during dry-docking. When deformation of the shell plating is found, the area should also be inspected internally since even a small deformation may indicate serious damage to the internal structure.

**4.2.2** Side shell plating in the foremost cargo hold maybe indented since the shell plating in the fore body has a large bow flare.

**4.3 Fractures**

**4.3.1** Fractures in the shell plating above and below the water line in way of ballast tanks may be detected during dry-docking, as wet areas, in contrast to otherwise dry shell plating.

**No.  
84**  
(cont)**5 General comments on repair****5.1 Material wastage**

**5.1.1** If the corrosion is caused by high stress concentrations, renewal of original thicknesses is not sufficient to avoid re-occurrence. Renewal with increased thickness and / or appropriate corrosion protection measures is to be considered in this case.

**5.2 Deformations**

**5.2.1** The cause of damage should always be identified. If the damage is due to negligence in operation, the ship's representative should be notified. If the deformation is caused by inadequate structural strength, appropriate reinforcement should be considered. Where the deformation is related to corrosion, appropriate corrosion protection measures should be considered.

**5.3 Fractures**

**5.3.1** If the cause of the fracture is fatigue under the action of cyclic wave loading, consideration should be given to the improvement of structural detail design, such as provision of a soft toe bracket, to reduce stress concentration. If the fatigue fracture is vibration related, the damage is usually associated with moderate stress levels at a high cycle rate, improvement of structural detail may not be effective. In this case, measures for increasing structural damping and avoidance of resonance, such as providing additional stiffening, may be considered.

Where fractures occur due to material under excessive stress, indicating inadequate structural strength, renewal with thicker plate and / or provision of appropriate reinforcement should be considered.

Where fractures are found in the transition region, measures for reducing the stress concentration due to structural discontinuity should be considered.

**5.3.2** In order to reduce stress concentration due to discontinuity appropriate transition structures are to be provided in the contiguous space. If such stiffeners are not provided, or are deficient due to corrosion or misalignment, fractures may occur at the terminations.

No. 84  
(cont)

CONTAINER SHIPS		Guidelines for Surveys, Assessment and Repair of Hull Structure	
Part 1	Cargo hold region	Example No. 1	
Area 2	Side structure including tanks		
<b>Detail of damage</b>		Fracture in side shell frame at lower bracket	
<b>Sketch of damage</b>		<b>Sketch of repair</b>	
<b>Notes on possible cause of damage</b>		<b>Notes on repairs</b>	
<p>1. This type of damage is caused due to stress concentration.</p>		<p>1. For small fractures, e.g. hairline fractures, the fracture can be veed-out, welded up, ground, examined by NDT for fractures, and rewelded.</p> <p>2. For larger / significant fractures consideration is to be given to cropping and partly renewing / renewing the frame brackets with longer arms. If renewing the brackets, end of frames can be sniped to soften them.</p> <p>3. If considered necessary soft toes may be incorporated at the end of bracket.</p>	

**No. 84**  
(cont)

<b>CONTAINER SHIPS</b>		<b>Guidelines for Surveys, Assessment and Repair of Hull Structure</b>	
<b>Part 1</b>	<b>Cargo hold region</b>	<b>Example No. 2-a</b>	
<b>Area 2</b>	<b>Side structure including tanks</b>		
<b>Detail of damage</b>	Fractures in side shell frame / lower bracket and side shell plating near tank top		
<b>Sketch of damage</b>		<b>Sketch of repair</b>	
		<p>Part renewal including side shell frames and inner bottom plating, as found necessary</p>	
<b>Notes on possible cause of damage</b>		<b>Notes on repairs</b>	
<ol style="list-style-type: none"> <li>1. Fracture in side shell plating along side shell frame: Heavy corrosion (grooving) along side shell frame (See A)</li> <li>2. Fracture in side shell plating along tank top: Heavy corrosion (grooving) along tank top (See B) resulting in detachment of side shell frame bracket from inner bottom plating.</li> </ol>		<ol style="list-style-type: none"> <li>1. Sketch of repair applies when damage extends over several frames.</li> <li>2. Isolated fractures may be repaired by veeing-out and rewelding.</li> <li>3. Isolated cases of grooving may be repaired by build up of welding.</li> </ol>	

**No. 84**  
(cont)

<b>CONTAINER SHIPS</b>		<b>Guidelines for Surveys, Assessment and Repair of Hull Structure</b>	
<b>Part 1</b>	<b>Cargo hold region</b>	<b>Example No. 2-b</b>	
<b>Area 2</b>	<b>Side structure including tanks</b>		
<b>Detail of damage</b>		Adverse effect of corrosion on the frame of forward / afterward hold	
<p><b>Sketch of damage</b></p> <p>The sketch illustrates the damage to the side shell frame. It shows a perspective view of the side shell frame of a forward/afterward hold. A section of the side shell frame is shown detached, labeled 'Detached side shell frame'. A box labeled 'Consequence of heavy corrosion' points to the damage. A detail view shows the side shell plating and side shell frame with throat thicknesses 'a' and 'b'.</p>		<p><b>Sketch of repair</b></p> <p>The sketch shows the repair of the side shell frame. It includes a list of repair steps:</p> <ol style="list-style-type: none"> <li>1. Part renewal including side shell frames and inner bottom plating, as found necessary.</li> <li>2. Deep penetration welding at the connections of side shell frame to side shell plating</li> </ol>	
<p><b>Notes on possible cause of damage</b></p> <p>1. Heavy corrosion (grooving) of side shell frame along side shell plating and difference of throat thickness "a" from "b". (Since original throat thickness of "a" is usually smaller than that of "b", if same welding procedure is applied, the same corrosion has a more severe effect on "a", and may cause collapse and / or detachment of side shell frame.)</p>		<p><b>Notes on repairs</b></p> <ol style="list-style-type: none"> <li>1. Sketch of repair applies when damage extends over several frames.</li> <li>2. Isolated fractures may be repaired by veeing-out and rewelding.</li> <li>3. Isolated cases of grooving may be repaired by build up of welding.</li> </ol>	

No.  
84

(cont)

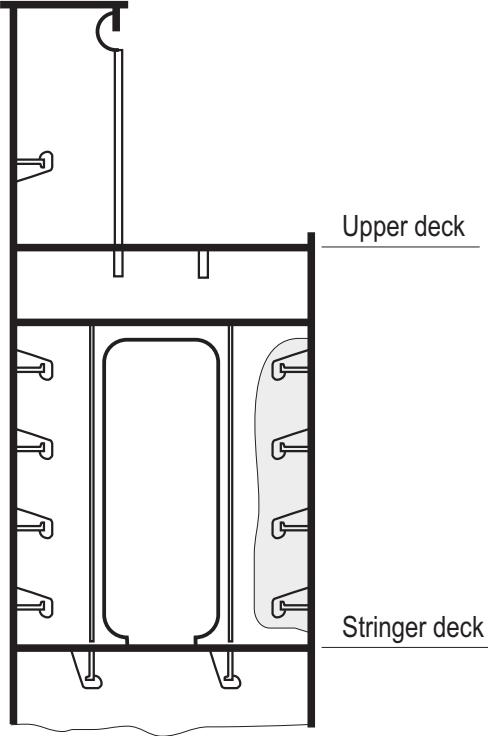
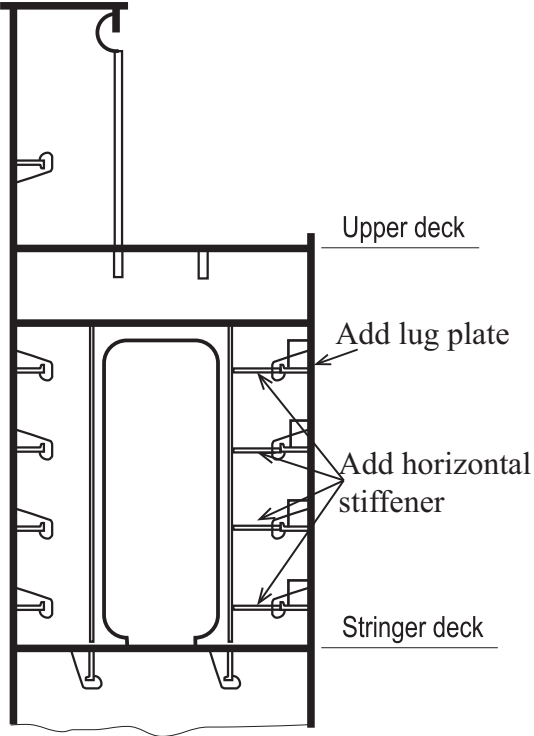
CONTAINER SHIPS		Guidelines for Surveys, Assessment and Repair of Hull Structure	
Part 1	Cargo hold region	Example No. 3-a	
Area 2	Side structure including tanks		
Detail of damage	Buckling of side structure in way of side tank / passage way		
Sketch of damage	Sketch of repair		
			
Notes on possible cause of damage	Notes on repairs		
<ol style="list-style-type: none"> <li>1. Deformation of web of transverse web frame and / or distortion of side longitudinals due to insufficient buckling strength.</li> <li>2. Insufficient strengthening of side structure in way of tug and / or fender area or misplacing of strengthened area, respectively.</li> </ol>	<ol style="list-style-type: none"> <li>1. Straightening or renewal (if necessary) of buckled web plate and distorted side longitudinals.</li> <li>2. Fitting of additional horizontal stiffeners on web plate in way of side longitudinals.</li> <li>3. Strengthening of tug or fender area or shifting of affected area to right position should be considered.</li> <li>4 Horizontal stiffeners may be connected to the vertical stiffeners or sniped in way of the vertical stiffener</li> </ol>		

**No. 84**  
(cont)

<b>CONTAINER SHIPS</b>		<b>Guidelines for Surveys, Assessment and Repair of Hull Structure</b>	
<b>Part 1</b>	<b>Cargo hold region</b>	<b>Example No. 3-b</b>	
<b>Area 2</b>	<b>Side structure including tanks</b>		
<b>Detail of damage</b>	<b>Buckling of side structure in way of fender</b>		
<b>Sketch of damage</b>		<b>Sketch of repair</b>	
<b>Notes on possible cause of damage</b>		<b>Notes on repairs</b>	
<p>1. Buckling of web of transverse web frame due to insufficient buckling strength in way of fender.</p>		<p>1. Straightening or renewal (if necessary) of buckled web plate and closing of cut-out for side longitudinal.</p> <p>2. Fitting of additional horizontal stiffeners on web plate in way of fender.</p> <p>Where the horizontal stiffeners extend to the vertical stiffener, they may be connected to the vertical stiffeners or sniped.</p>	

No.  
84

(cont)

CONTAINER SHIPS		Guidelines for Surveys, Assessment and Repair of Hull Structure	
Part 1	Cargo hold region	Example No. 4-a	
Area 2	Side structure including tanks		
Detail of damage	Fractures and buckling in way of a cut-out for the passage of a longitudinal through a transverse web		
Sketch of damage	<p>Transversen web frame</p> <p>Side shell plating or longitudinal bulkhead plating</p> <p>Longitudinal</p> <p>Buckling and /or fracturing</p> <p>Fracture inside shell plating</p>		
Sketch of repair	<p>Repair A</p> <p>New web plating of enhanced thickness</p> <p>Lug introduced</p> <p>Repair B</p> <p>Full collar plate</p> <p>Full collar plate</p>		
Notes on possible cause of damage	<p>1. Damage can be caused by general levels of corrosion and presence of stress concentration associated with the presence of a cut-out.</p>		
Notes on repairs	<p>1. If fractures are significant then crop and part renew the web plating otherwise the fracture can be veed-out and welded provided the plating is not generally corroded.</p> <p>2. <b>Repair B</b> is to be incorporated if the lug proves to be ineffective.</p>		



**No. 84**  
(cont)

<b>CONTAINER SHIPS</b>		<b>Guidelines for Surveys, Assessment and Repair of Hull Structure</b>	
<b>Part 1</b>	<b>Cargo hold region</b>	<b>Example No. 4-b</b>	
<b>Area 2</b>	<b>Side structure including tanks</b>		
<b>Detail of damage</b>	<b>Fractures at the connection of side shell longitudinal to transverse web</b>		
<b>Sketch of damage</b>		<b>Sketch of repair</b>	
<p>Transverse web</p> <p>Side shell plating or longitudinal bulkhead plating</p> <p>Longitudinal</p> <p>Stiffener</p> <p>Longitudinal</p> <p>Fractures</p> <p>Transverse web</p> <p>Side shell plating or longitudinal bulkhead plating</p>		<p>Stiffener</p> <p>Additional bracket with soft toes fitted</p> <p>R2</p> <p>R1</p> <p>Transverse</p> <p>Side shell</p> <p><math>b2 = 1.5 a</math></p> <p><math>b1 = 2.5 a</math></p>	
<b>Notes on possible cause of damage</b>		<b>Notes on repairs</b>	
<p>1. Damage can be caused by stress concentrations leading to accelerated fatigue in this region.</p>		<p>1. If fracture extends to over one third of the depth of the longitudinal, then crop and part renew. Otherwise the fracture can be veed-out and welded.</p>	
		<p>*) Where required, the longitudinal to be cropped and part renewed</p> <ol style="list-style-type: none"> <li>1. For a slope at toes max. 1:3, <math>R1 = (b1 - h) \times 1.6</math> and <math>R2 = (b2 - h) \times 1.6</math></li> <li>2. Soft toe bracket to be welded first to longitudinal</li> <li>3. Scallop in bracket to be as small as possible recommended max. 35 mm</li> <li>4. If toes of brackets are ground smooth, full penetration welds in way to be provided</li> <li>5. Maximum length to thickness ratio = 50:1 for unstiffened bracket edge</li> <li>6. Toe height, h, to be as small as possible (10-15 mm)</li> </ol>	

**No. 84**  
(cont)

<b>CONTAINER SHIPS</b>		<b>Guidelines for Surveys, Assessment and Repair of Hull Structure</b>	
<b>Part 1</b>	<b>Cargo hold region</b>	<b>Example No. 4-c</b>	
<b>Area 2</b>	<b>Side structure including tanks</b>		
<b>Detail of damage</b>	Fractures at the connection of side shell longitudinal to transverse web		
<b>Sketch of damage</b>	<b>Sketch of repair</b>		
		<p>*) Where required, the longitudinal to be cropped and part renewed</p> <p>Various cut-out shapes have been developed. The following is one example:</p> <ol style="list-style-type: none"> <li>1. Toe height as small as possible (h= 10-15 mm)</li> <li>2. Depth "d" of key hole notch as small a possible, max. 30 mm</li> <li>3. For a slope at toe max. 1:3</li> <li>4. <math>R1 = 1.5 d</math>; <math>R2 = d</math> and <math>R3 = 1.5 c</math></li> </ol>	
<b>Notes on possible cause of damage</b>		<b>Notes on repairs</b>	
<ol style="list-style-type: none"> <li>1. Damage can be caused by stress concentrations leading to accelerated fatigue in this region.</li> </ol>		<ol style="list-style-type: none"> <li>1. If fracture extends to over one third of the depth of the longitudinal, then crop and part renew. Otherwise the fracture can be veed-out and welded.</li> </ol>	

**No. 84**  
(cont)

<b>CONTAINER SHIPS</b>		<b>Guidelines for Surveys, Assessment and Repair of Hull Structure</b>	
<b>Part 1</b>	<b>Cargo hold region</b>	<b>Example No. 4-d</b>	
<b>Area 2</b>	<b>Side structure including tanks</b>		
<b>Detail of damage</b>	Fractures at the connection of side shell longitudinal to transverse bulkhead		
<b>Sketch of damage</b>		<b>Sketch of repair</b>	
		<p>Note: Regarding detail of brackets see 4-b</p>	
<b>Notes on possible cause of damage</b>		<b>Notes on repairs</b>	
<p>1. Damage can be caused by stress concentrations leading to accelerated fatigue in this region.</p>		<p>1. If fracture extends to over one third of the depth of the longitudinal, then crop and part renew. Otherwise the fracture can be veed-out and welded.</p>	

**No. 84**  
(cont)

<b>CONTAINER SHIPS</b>		<b>Guidelines for Surveys, Assessment and Repair of Hull Structure</b>	
<b>Part 1</b>	<b>Cargo hold region</b>	<b>Example No. 5</b>	
<b>Area 2</b>	<b>Side structure including tanks</b>		
<b>Detail of damage</b>	Fractures in side shell plating/longitudinal bulkhead plating at the corner of drain hole in longitudinal		
<b>Sketch of damage</b>		<b>Sketch of repair</b>	
<p>Fractures</p> <p>Drain hole or air hole</p> <p>Side shell plating or longitudinal bulkhead plating</p> <p>Longitudinal</p> <p>Fractures</p>		<p>New insert plate</p>	
<b>Notes on possible cause of damage</b>		<b>Notes on repairs</b>	
<p>1. Stress concentration and/or corrosion due to stress concentration at the corner of drain hole/air hole.</p>		<p>1. Fractured plating should be cropped and part renewed.</p> <p>If fatigue life is to be improved, change of drain hole/air hole shape is to be considered.</p>	

**No. 84**  
(cont)

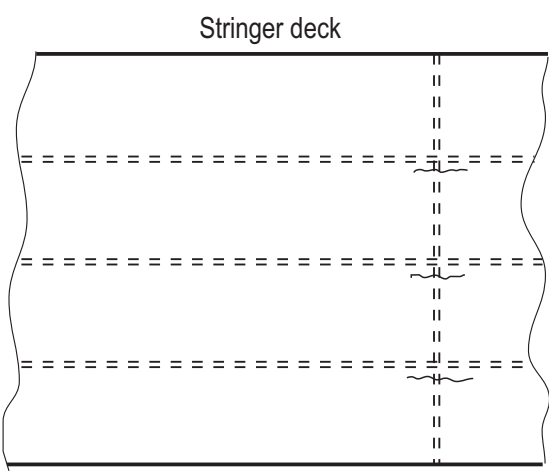
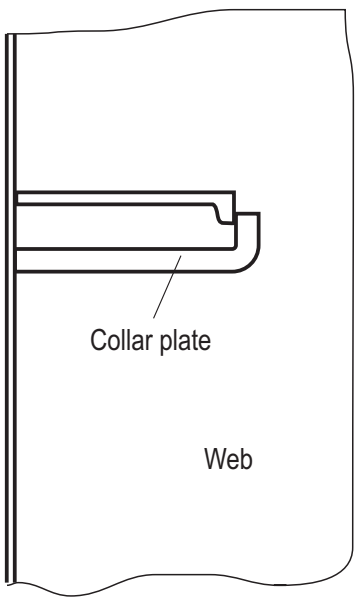
<b>CONTAINER SHIPS</b>		<b>Guidelines for Surveys, Assessment and Repair of Hull Structure</b>	
<b>Part 1</b>	<b>Cargo hold region</b>	<b>Example No. 6</b>	
<b>Area 2</b>	<b>Side structure including tanks</b>		
<b>Detail of damage</b>	Fractures in side wall (raised tank) at the connection of longitudinals to web of transverses		
<b>Sketch of damage</b>		<b>Sketch of repair</b>	
 <p style="text-align: center;">Stringer deck</p>			
<b>Notes on possible cause of damage</b>		<b>Notes on repairs</b>	
<p>1. Damage can be caused by stress concentration leading to accelerated fatigue in this region.</p>		<p>1. Fractured side wall plating to be cropped and renewed by insert plate.</p> <p>2. Cut-outs for longitudinals to be closed by collar plates.</p>	

**No. 84**  
(cont)

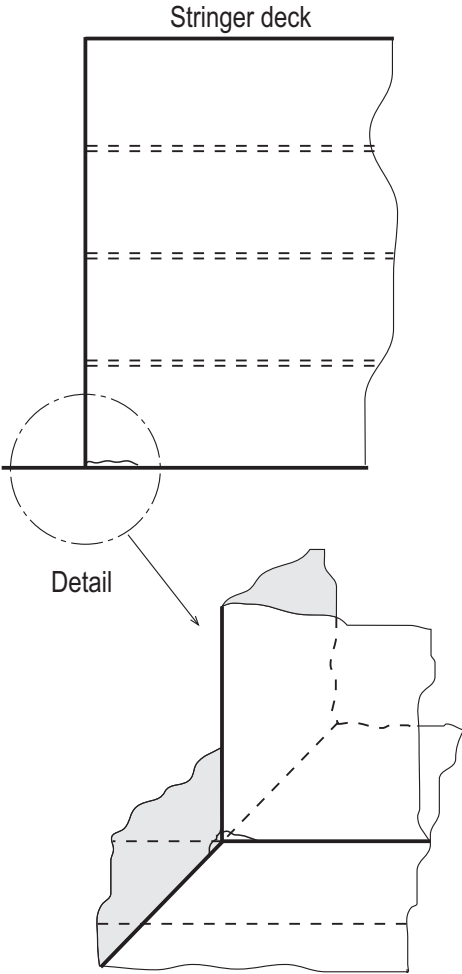
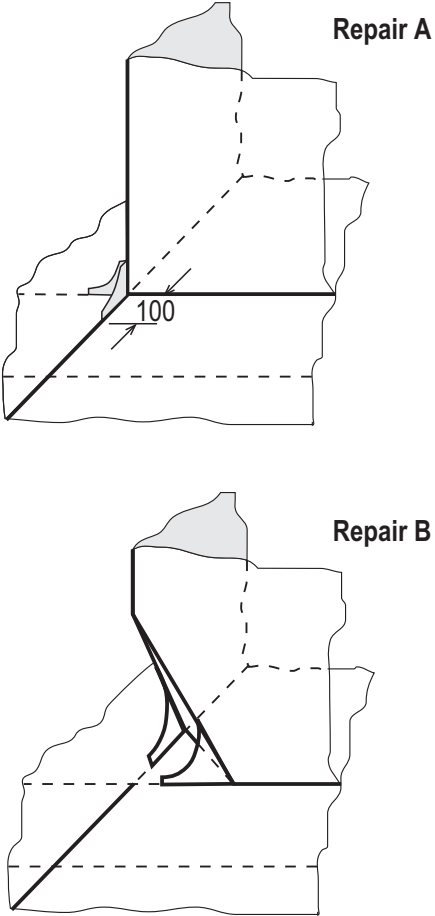
<b>CONTAINER SHIPS</b>		<b>Guidelines for Surveys, Assessment and Repair of Hull Structure</b>	
<b>Part 1</b>	<b>Cargo hold region</b>	<b>Example No. 7</b>	
<b>Area 2</b>	<b>Side structure including tanks</b>		
<b>Detail of damage</b>	Fractures at the termination of stringer deck (raised tank)		
<b>Sketch of damage</b>		<b>Sketch of repair</b>	
 <p>The sketch shows a cross-section of a stringer deck. The top part is labeled 'Stringer deck'. A horizontal dashed line indicates a fracture at the termination of the deck. A circular callout labeled 'Detail' points to a close-up of the fracture area, showing a jagged break in the metal.</p>		 <p>Repair A shows a bracket with a 100 mm length. Repair B shows a modified design with a soft nose transition.</p>	
<b>Notes on possible cause of damage</b>		<b>Notes on repairs</b>	
<p>1. Damage can be caused by stress concentration leading to fatigue in this region.</p>		<p>1. Fracture in tank top plating to be cropped and renewed by insert.</p> <p>2. Repair A: Small brackets should be provided at the termination in longitudinal and / or transverse direction (proposed length about 100 mm)</p> <p>3. Repair B: Modification of the design with soft nose transition should be considered.</p>	

**No. 84**  
(cont)

<b>CONTAINER SHIPS</b>		<b>Guidelines for Surveys, Assessment and Repair of Hull Structure</b>	
<b>Part 1</b>	<b>Cargo hold region</b>	<b>Example No. 8</b>	
<b>Area 2</b>	<b>Side structure including tanks</b>		
<b>Detail of damage</b>	Fracture in stringer deck in way of container sockets		
<b>Sketch of damage</b>		<b>Sketch of repair</b>	
<b>Notes on possible cause of damage</b>		<b>Notes on repairs</b>	
<ol style="list-style-type: none"> <li>1. Stress concentration in the radiused corner in combination with stress concentration due to the arrangement of two separate container sockets.</li> <li>2. Missing or insufficient support by internal structure in way of the container sockets.</li> </ol>		<ol style="list-style-type: none"> <li>1. Fractured plating of stringer deck to be cropped and renewed by insert.</li> <li>2. Use of a combined container socket instead of two separate sockets.</li> <li>3. Additional supporting structures should be considered, if necessary.</li> </ol>	

**No. 84**  
(cont)

<b>CONTAINER SHIPS</b>		<b>Guidelines for Surveys, Assessment and Repair of Hull Structure</b>	
<b>Part 1</b>	<b>Cargo hold region</b>	<b>Example No. 9</b>	
<b>Area 2</b>	<b>Side structure including tanks</b>		
<b>Detail of damage</b>	Fracture in side longitudinal in way of side tank		
<b>Sketch of damage</b>		<b>Sketch of repair</b>	
<b>Notes on possible cause of damage</b>		<b>Notes on repairs</b>	
<p>1. Stress concentration at the connection between bulkhead stringer and side longitudinal.</p>		<p>1. Damaged side longitudinal is to be cropped off and renewed</p> <p>2. Consideration is to be given to removal of the horizontal stiffener and brackets on the bulkhead and replacing them with new (similar) brackets. Technical staff of the Classification Society should be consulted prior to removal structure.</p>	



---

**No. 84**      **Area 3 Transverse bulkhead structure****84**  
(cont)**Contents**

- 1    General**
  
- 2    What to look for**
  - 2.1   Material wastage**
  - 2.2   Deformations**
  - 2.3   Fractures**
  
- 3    General comments on repair**
  - 3.1   Material wastage**
  - 3.2   Deformations**
  - 3.3   Fractures**

**Examples of structural detail failures and repairs – Area 3**

<b>Example No.</b>	<b>Title</b>
1	Corrosion along inner bottom plating
2	Buckling in transverse bulkhead
3	Fractures in cut-outs for vertical stiffeners
4	Fractures at the corner of access cut-outs
5	Fractures around staircase hole in security platform

**No.  
84**  
(cont)**1 General**

**1.1** Two different types of transverse bulkheads are found in the cargo holds of container ships: watertight bulkheads and non-watertight bulkheads. The transverse bulkheads are located at the end of each cargo hold and are commonly constructed as plane double plated bulkheads with internal stiffening. In general every second transverse bulkhead is watertight i.e. with watertight plating on one side and with large cut-outs on the opposite side. The non-watertight bulkhead is constructed as plane double plated bulkhead with large cut-outs in the plating on both sides. Normally cell guides are fitted at the bulkheads in order to guide the containers during loading and unloading as well as to support the containers during the voyage. The bulkheads serve as main transverse strength elements in the structural design of the ship. Additionally the watertight bulkhead serves as a subdivision to prevent progressive flooding in an emergency situation.

**1.2** The structure may sometimes appear to be in good condition when it is in fact excessively corroded. Heavy corrosion may lead to collapse of the structure under an extreme load, if it is not rectified properly.

**1.3** Deformation of the plating may lead to the failure and collapse of the bulkhead under water pressure in an emergency situation. As a secondary consideration, deformations could interfere in ships loading and unloading operations in blocking container boxes inside cell guides.

**2 What to look for****2.1 Material wastage**

**2.1.1** If coatings have broken down and there is evidence of corrosion, it is recommended that random thickness measurements be taken to establish the level of diminution.

**2.1.2** Where the terms and requirements of the periodical survey dictate thickness measurement, or when the surveyor deems necessary, it is important that the extent of the gauging be sufficient to determine the general condition of the structure.

**2.1.3** Particular attention is to be paid to the lower part of the bulkhead in cargo holds which can be subject to heavy corrosion due to water remaining.

**2.2 Deformations**

**2.2.1** Deformation due to mechanical damage is often found in bulkhead structures due to rough cargo handling operations.

**2.2.2** When the bulkhead has sustained serious uniform corrosion, the bulkhead may suffer shear buckling. Evidence of buckling may be indicated by the peeling of paint or rust. However, where deformation resulting from bending or shear stresses has occurred on a bulkhead with a small diminution in thickness, this could be due to poor design or the stack load has been exceeded and this aspect should be investigated before proceeding with repairs.

**2.2.3** Frequently cell guides and their connections to the bulkhead structure have been deformed or distorted.

**No.  
84**  
(cont)**2.3 Fractures**

**2.3.1** Fractures usually occur in the stringer in way of the cut-outs for vertical stiffeners and in way of the access cut-outs.

**2.3.2** In the case of heavily deformed and distorted cell guides fractures in the cell guide and/or in the connection to the bulkhead structure can be observed.

**3 General comments on repair****3.1 Material wastage**

**3.1.1** When the reduction in thickness of plating and stiffeners has reached the diminution levels permitted by the Classification Society involved, the wasted plating and stiffeners are to be cropped and renewed.

**3.2 Deformations**

**3.2.1** If the deformation is local and of a limited extent, it could generally be faired out. Deformed plating in association with a generalized reduction in thickness should be partly or completely renewed.

**3.2.2** Buckling of the bulkhead plating can also occur in way of the side shell resulting from contact damage and this is usually quite obvious. In such cases the damaged area is to be cropped and partly renewed. If the deformation is extensive, replacement of the plating, partly or completely, may be necessary. If the deformation is not in association with generalized reduction in thickness or due to excessive loading, additional strengthening should be considered.

**3.2.3** Deformed and distorted cell guides and their connections to bulkhead structure are to be faired or cropped and renewed.

**3.3 Fractures**

**3.3.1** Fractures that occur at the boundary weld connections as a result of latent weld defects should be veed-out, appropriately prepared and re-welded preferably using low hydrogen electrodes or equivalent.

**3.3.2** For fractures other than those described above, re-welding may not be a permanent solution and an attempt should be made to improve the design and construction in order to obviate a recurrence.

**No. 84**  
(cont)

<b>CONTAINER SHIPS</b>		<b>Guidelines for Surveys, Assessment and Repair of Hull Structure</b>	
<b>Part 1</b>	<b>Cargo hold region</b>	<b>Example No. 1</b>	
<b>Area 3</b>	<b>Transverse bulkhead structure</b>		
<b>Detail of damage</b>		Corrosion along inner bottom plating	
<b>Sketch of damage</b>		<b>Sketch of repair</b>	
<p>The sketch shows a grid of stiffeners and transverse bulkhead plating. The bottom edge is labeled 'Inner Bottom plating'. There is a shaded area at the bottom right labeled 'Heavy local corrosion (fracture / hole)'. A wavy line indicates corrosion along the inner bottom plating.</p>		<p>The sketch shows the same grid as the damage sketch, but with a shaded rectangular area representing the repair plate welded to the bottom.</p>	
<b>Notes on possible cause of damage</b>		<b>Notes on repairs</b>	
<ol style="list-style-type: none"> <li>1. Heavy corrosion including grooving along inner bottom.</li> </ol>		<ol style="list-style-type: none"> <li>1. The extent of the renewal should be determined carefully. If the renewal plate (original thickness) is welded to thin plate (corroded plate), it may cause stress concentration and cause fracture.</li> <li>2. Protective coating should be applied.</li> </ol>	

**No. 84**  
(cont)

CONTAINER SHIPS		Guidelines for Surveys, Assessment and Repair of Hull Structure	
Part 1	Cargo hold region	Example No. 2	
Area 3	Transverse bulkhead structure		
Detail of damage	Buckling in transverse bulkhead		
Sketch of damage			
Sketch of repair			
Notes on possible cause of damage	Notes on repairs		
<ol style="list-style-type: none"> <li>1. Heavy general corrosion.</li> </ol>	<ol style="list-style-type: none"> <li>1. The extent of the renewal should be determined carefully. If the renewal plating (original thickness) is welded to thin plating (corroded plating), it may cause stress concentration and fracture.</li> <li>2. Protective coating should be applied.</li> </ol>		

**No. 84**  
(cont)

<b>CONTAINER SHIPS</b>		<b>Guidelines for Surveys, Assessment and Repair of Hull Structure</b>	
<b>Part 1</b>	<b>Cargo hold region</b>	<b>Example No. 3</b>	
<b>Area 3</b>	<b>Transverse bulkhead structure</b>		
<b>Detail of damage</b>	Fractures in cut-outs for vertical stiffeners		
<b>Sketch of damage</b>		<b>Sketch of repair</b>	
<b>Notes on possible cause of damage</b>		<b>Notes on repairs</b>	
<p>1. Damage caused by stress concentration leading to fatigue fractures.</p>		<p>1. The fractured plating is to be cropped and part renewed as necessary.</p> <p>2. Collar plates to cut-outs are to be installed.</p>	

No.  
84

(cont)

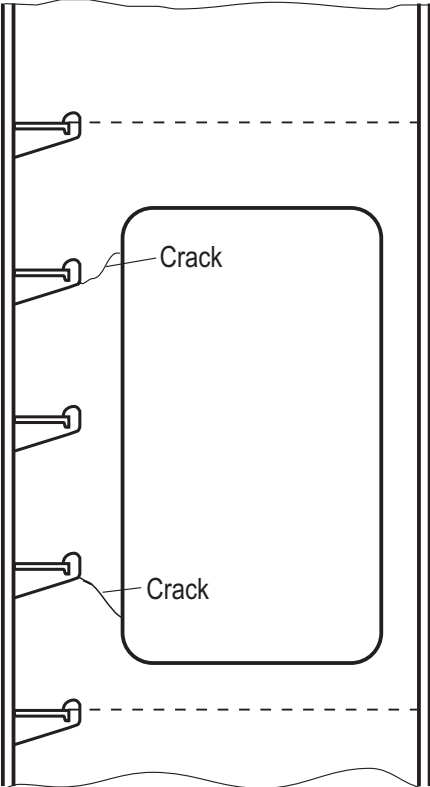
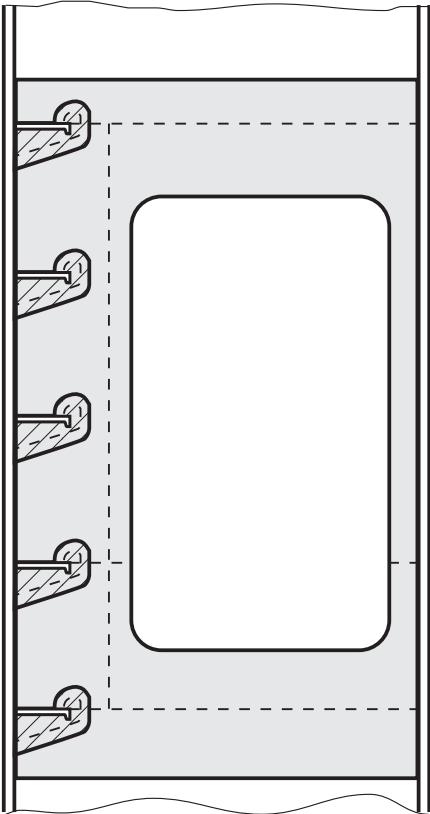
CONTAINER SHIPS		Guidelines for Surveys, Assessment and Repair of Hull Structure	
Part 1	Cargo hold region	Example No.	
Area 3	Transverse bulkhead structure	4	
Detail of damage		Fractures at the corners of access cut-outs	
<b>Sketch of damage</b> 		<b>Sketch of repair</b> 	
<b>Notes on possible cause of damage</b> 1. Damages caused by stress concentration leading to fatigue fractures.		<b>Notes on repairs</b> 1. Insertion of plating of increased thickness (chamfer 1:3 to 1:5). 2. Collar plates to cut-outs for vertical stiffeners are to be installed. 3. Additional stiffener adjacent to access opening to be fitted 4. Reduction in size of access hole to be considered	

No. 84  
(cont)

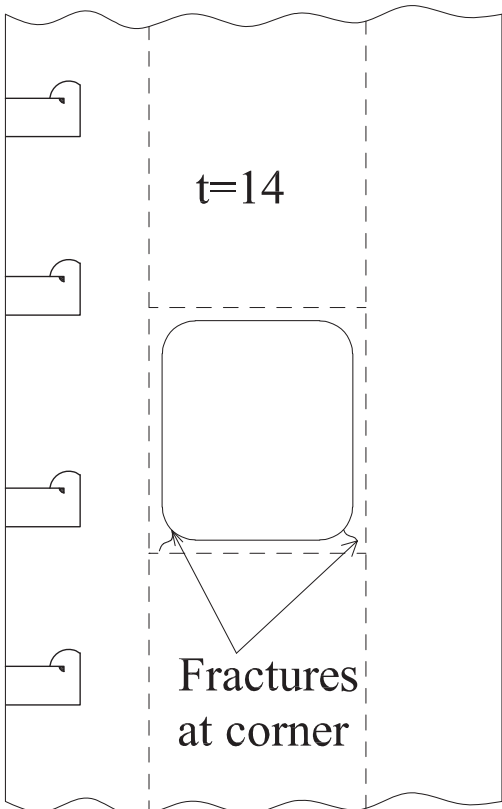
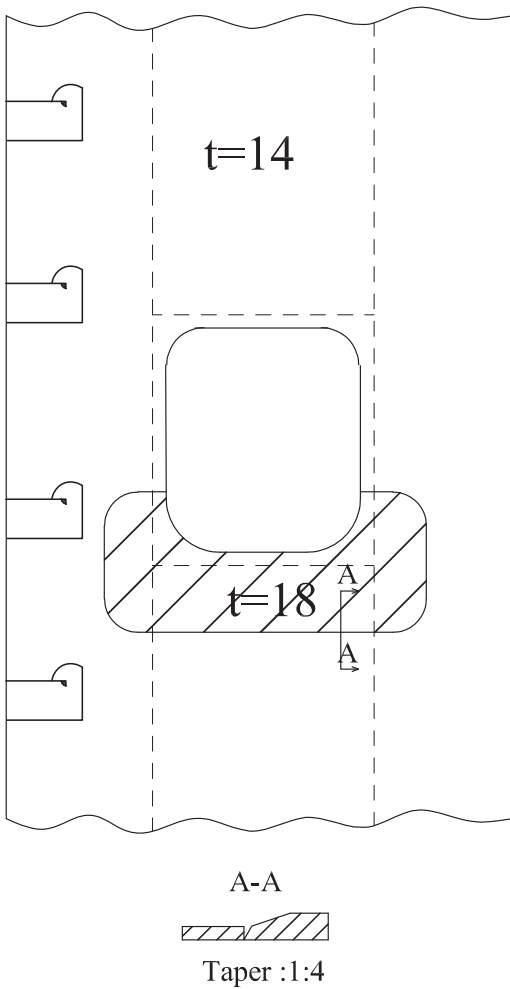
CONTAINER SHIPS		Guidelines for Surveys, Assessment and Repair of Hull Structure	
Part 1	Cargo hold region	Example No. 5	
Area 3	Transverse bulkhead structure		
Detail of damage		Fractures around staircase hole in security platform	
Sketch of damage		Sketch of repair	
<p style="text-align: center;">Staircase hole</p> 		<p style="text-align: center;">Staircase hole</p>  <p style="text-align: center;">A-A Taper :1:4</p>	
<p><b>Notes on possible cause of damage</b></p> <ol style="list-style-type: none"> <li>1 Too small corner radius and/or insufficient local plate thickness.</li> </ol>		<p><b>Notes on repairs</b></p> <ol style="list-style-type: none"> <li>1. Damaged plates are to be cropped and inserted with thicker plates.</li> <li>2. A larger corner radius is to be considered.</li> </ol>	



## No. 84 Area 4 Double bottom structure

84  
(cont)

### Contents

- 1 General
- 2 What to look for – Tank top inspection
  - 2.1 Material wastage
  - 2.2 Deformations
  - 2.3 Fractures
- 3 What to look for – Double bottom tank inspection
  - 3.1 Material wastage
  - 3.2 Deformations
  - 3.3 Fractures
- 4 What to look for – External bottom inspection
  - 2.1 Material wastage
  - 2.2 Deformations
  - 2.3 Fractures
- 5 General comments on repair
  - 5.1 Material wastage
  - 5.2 Deformations
  - 5.3 Fractures

### Figures and/or Photographs – Area 4

No.	Title
Figure 1	Example of buckling deformation observed in the bottom shell plating under cargo hold amidships
Figure 2	Grooving corrosion of weld of bottom plating
Figure 3	Section of the grooving shown in Figure 1

**No.**  
**84**  
(cont)

**Examples of structural detail failures and repairs – Area 4**

**Example No. Title**

1	Fractures in inner bottom plating around container bottom pocket
2	Fractures, corrosion and/or buckling of floor/girder around lightening hole
3	Fractures in longitudinal at floor or bulkhead
4	Fractures in longitudinal girders in way of container support
5	Fractures in longitudinal in way of bilge well
6	Fractures in bottom shell inner bottom plating at the corner of drain hole/air hole in longitudinal
7	Fractures in bottom shell plating alongside girder and/or bottom longitudinal
8	Corrosion in bottom shell plating below suction head
9	Corrosion in bottom shell plating below sounding pipe
10	Deformation of forward bottom shell plating due to slamming
11	Fractures in bottom shell plating at the termination of bilge keel
12	Fracture in the tank top plate in way of the height transition of inner bottom

**No.  
84**  
(cont)**1 General**

**1.1** In addition to contributing to the longitudinal bending strength of the hull girder, the double bottom structure provides support for the cargo in the holds. The tank top structure is subjected to impact forces of containers during loading and unloading operations. The bottom shell at the forward part of the ship may sustain increased dynamic forces caused by slamming in heavy weather

**1.2** Normally, on container ships, a strict observance of a maintenance programme in the cargo holds could be difficult due to the fact that cargo holds are very seldom completely empty. Therefore, the tank top and the adjacent areas of bulkheads are prone to increased corrosion and need particular attention during inspections

**2 What to look for – Tank top inspection****2.1 Material wastage**

**2.1.1** The general corrosion condition of the tank top structure may be observed by visual inspection. The level of wastage of tank top plating may have to be established by means of thickness measurement. Special attention should be given to the intersection of the tank top with transverse bulkheads and side shell or longitudinal side tank bulkheads, respectively, where water may have accumulated and consequently accelerated the rate of corrosion.

**2.1.2** The bilge wells should be cleaned and inspected closely since heavy pitting corrosion may have occurred due to accumulated water or corrosive solutions in the wells. Special attention should be paid to the plating in way of the bilge suction and sounding pipes.

**2.1.3** Special attention should also be paid to areas where pipes penetrate the tank top.

**2.2 Deformations**

**2.2.1** Buckling of the tank top plating may occur between longitudinals in areas subject to in-plane transverse compressive stresses or between floors in areas subject to in-plane longitudinal compressive stresses. Buckling of tank top plating in way of and/or nearby heated fuel oil tanks can be found in particular in case of a combination with pre-deformations due to the production process.

**2.2.2** Deformed structures may be observed in areas of the tank top due to overloading or the impact of containers during loading/unloading operations, in particular in the case of insufficient, missing or misplaced sub-structures in way of container sockets.

**2.2.3** Whenever deformations are observed on the tank top, further inspection in the double bottom tanks is imperative in order to determine the extent of the damage. The deformation may cause the breakdown of coatings within the double bottom, which in turn may lead to an accelerated corrosion rate in these unprotected areas.

**2.3 Fractures**

**2.3.1** Fractures will normally be found by close-up survey. Fractures that extend through the thickness of the plating or through the welds may be observed during pressure testing of the double bottom tanks.

**No.  
84**  
(cont)**3 What to look for – Double bottom tank inspection****3.1 Material wastage**

**3.1.1** The level of wastage of double bottom internal structure (longitudinals, transverses, floors, girders, etc.) may have to be established by means of thickness measurements. The rate and extent of corrosion depends on the corrosive environment, and protective measures employed, such as coatings and sacrificial anodes. The following structures are generally susceptible to corrosion (also see **3.1.2 - 3.1.4**).

**a) Structure in corrosive environment:**

Back side of inner bottom plating and inner bottom longitudinals Transverse watertight floors and girders adjacent to a heated fuel oil tank

**(b) Structure subject to high stress:**

Connection of longitudinals to transverse floors

**(c) Areas susceptible to coating breakdown:**

Back side of longitudinal face plates

Welded joints

Edges of access openings

**(d) Areas subjected to poor drainage:**

Web of bilge side longitudinals

Stringer deck

**3.1.2** If the protective coating is not properly maintained, structure in the ballast tank may suffer severe localised corrosion. In general, structure at the upper part of the double bottom tank usually has more severe corrosion than that at the lower part.

**3.1.3** The high temperature due to heated fuel oil may accelerate corrosion of ballast tank structure near heated fuel tanks. The rate of corrosion depends on several factors such as:

- temperature and heat input to the ballast tank.
- condition of original coating and its maintenance.

(It is preferable for application and maintenance of ballast tank coatings that stiffeners on contiguous boundaries be fitted inside the – uncoated – fuel tank.)

- ballasting frequency and operations.
- age of ship and associated stress levels as corrosion reduces the thickness of the structural elements and can result in fracturing and buckling.

**3.1.4** Shell plating below the suction head often suffers localized wear caused by erosion and cavitation because of the fluid flowing through the suction head. In addition, the suction head will be positioned in the lowest part of the tank and water/mud will cover the area even when the tank is empty. The condition of the shell plating may be established by hand by feeling beneath the suction head. When in doubt, the lower part of the suction head should be removed and thickness measurements taken. If the vessel is docked, the thickness can be measured from below. If the distance between the suction head and the underlying shell plating is too small to permit access, the suction head should be dismantled. The shell plating below the sounding pipe should also be carefully examined. When a striking plate has not been fitted or is worn out, heavy corrosion can be caused by the striking of the weight of the sounding tape (See **Example 2 in Part 3**).

# No. 84

(cont)

## 3.2 Deformations

**3.2.1** Where deformations are identified during tank top inspection (See **2.2**) and external bottom inspection (See **4.2**), the deformed areas should be subjected to in tank inspection to determine the extent of the damage to the coating and internal structure.

**3.2.2** For large container ships (8,000 TEU or over), even if no obvious deformations are identified during external bottom inspection, if small concave and convex deformations of bottom plates are detected during the in tank inspection, the adjacent areas of bottom plates should be carefully inspected for the similar deformations, which might be caused by the effect of the lateral loads which induce bi-axial stress of bottom shell plates. In such cases a strength assessment of the hull girder should be undertaken by the Classification Society.

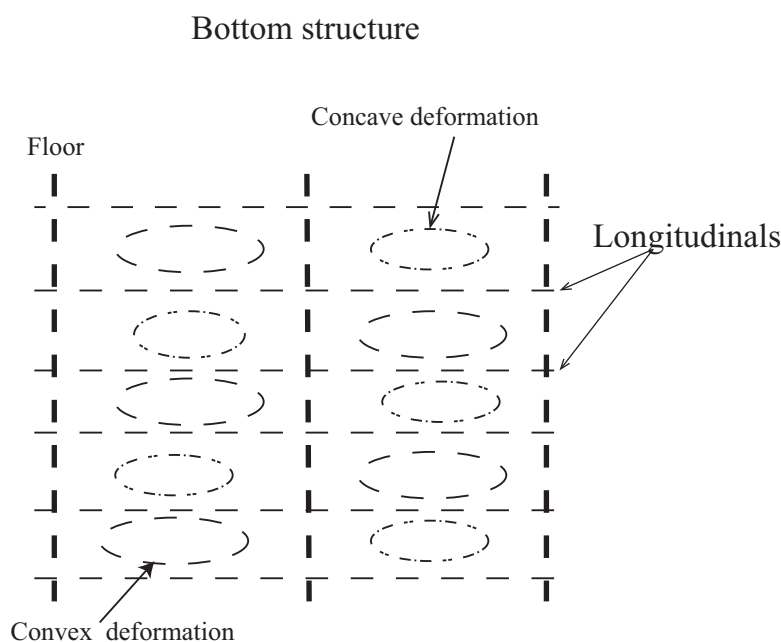

**Figure 1 – Buckling deformation observed in the bottom shell plating in way of cargo hold amidships**

Deformations in the structure not only reduce the structural strength but may also cause breakdown of the coating, leading to accelerated corrosion.

## 3.3 Fractures

**3.3.1** Fractures are more likely to be found by close-up survey.

**3.3.2** Fractures may be caused by the cyclic deflection of the inner bottom induced by repeated loading from the sea or due to poor 'through thickness' properties of the inner bottom plating. Scallops in the underlying girders can create stress concentrations which further increase the risk of fractures.

These can be categorised as follows.

(a) Fractures in the inner bottom longitudinals and the bottom longitudinals in way of the intersection with the watertight floors below the transverse bulkhead, especially in way of suction wells.

# No. 84 (cont)

(b) Fractures at the connection between the longitudinals and the vertical stiffeners or brackets on the floors, as well as at the corners of the duct keel.

### 3.3.3 Transition region

In general, the termination of the following structural members at the collision bulkhead and engine room forward bulkhead is prone to fractures:

- side tank structure
- panting stringer in fore peak tank
- inner bottom plating in engine room

## 4 What to look for – External bottom inspection

### 4.1 Material wastage

**4.1.1** Hull structure below the water line can usually be inspected only when the ship is dry-docked. The opportunity should be taken to inspect the external plating thoroughly. The level of wastage of the bottom plating may have to be established by means of thickness measurements.

**4.1.2** Severe grooving along welding of bottom plating is often found (See Figure 4-2 and 23). This grooving can be accelerated by poor maintenance of the protective coating and/or sacrificial anodes fitted to the bottom plating.

**4.1.3** Bottom or “docking” plugs should be carefully examined for excessive corrosion along the edge of the weld connecting the plug to the bottom plating.

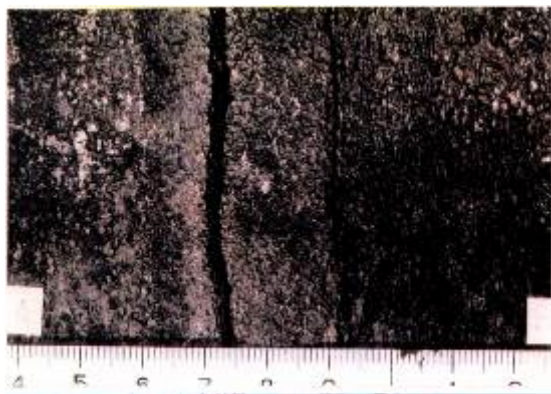

**Figure 2**  
Grooving corrosion of welding of bottom plating

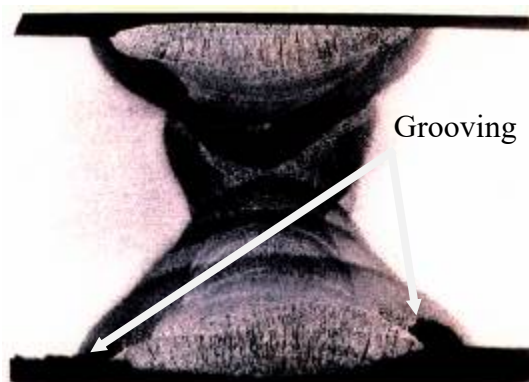

**Figure 3**  
Section of the grooving shown in Figure 2

**No.  
84**  
(cont)**4.2 Deformations**

**4.2.1** Buckling of the bottom shell plating may occur between longitudinals or floors in areas subject to in-plane compressive stresses (either longitudinally or transversely). Deformations of bottom plating may also be attributed to dynamic force caused by wave slamming action at the forward part of the vessel, or contact with underwater objects. When deformation of the shell plating is found, the affected area should be inspected internally. Even if the deformation is small, the internal structure may have suffered serious damage.

**4.3 Fractures**

**4.3.1** The bottom shell plating should be inspected when the hull has dried since fractures in shell plating can easily be detected by observing leakage of water from the fractures in clear contrast to the dry shell plating. Therefore if the ship has been inspected while wet, it is recommended that the ship be inspected again when dry.

**4.3.2** Fractures in butt welds and fillet welds, particularly at the wrap around at scallops and ends of bilge keel, are sometimes observed and may propagate into the bottom plating. The cause of fractures in butt welds is usually related to a weld defect or grooving. If the bilge keels are divided at the block joints of the hull, all ends of the bilge keels should be inspected.

**5 General comments on repair****5.1 Material wastage**

**5.1.1** In general, where the tank top, double bottom internal structure, and bottom shell plating have wasted to the allowable level, the normal practice is to crop and renew the affected area. Where possible, plate renewals should be for the full width of the plate but in no case should they be less than the minimum set in paragraph 6.2 of Part B of IACS Recommendation 47, to avoid build-up of residual stresses due to welding. Repair work on a double bottom will require careful planning in terms of accessibility and gas freeing is required for repair work in fuel oil tanks.

**5.1.2** Plating below suction heads and sounding pipes is to be replaced if the average thickness is below the acceptable limit (See **Examples 8 and 9**). When scattered deep pitting is found, it may be repaired by welding, when performed in accordance with procedures agreed with the Society.

**5.2 Deformations**

**5.2.1** Extensively deformed tank top and bottom plating should be replaced together with the deformed portion of girders, floors or transverse web frames. If there is no evidence that the deformation was caused by grounding or other excessive local loading, or that it is associated with excessive wastage, additional internal stiffening may need to be provided. In this regard, the Classification Society concerned should be contacted.

**5.3 Fractures**

**5.3.1** Repair should be carried out in consideration of nature and extent of the fractures.

(a) Fractures of a minor nature may be veed-out and rewelded. Where fracturing is more extensive, the structure is to be cropped and renewed.

**No.  
84**  
(cont)

- (b) For fractures caused by the cyclic deflection of the double bottom, reinforcement of the structure may be required in addition to cropping and renewal of the fractured part.
- (c) For fractures due to poor through thickness properties of the plating, cropping and renewal with steel having adequate through thickness properties is an acceptable solution.

**5.3.2** The fractures in the internal structures of the double bottom should be repaired as follows.

- (a) Fractures in the inner bottom longitudinals and the bottom longitudinals in way of the intersection with watertight floors are to be cropped and partly renewed. In addition, brackets with soft toes are to be fitted in order to reduce the stress concentrations at the floors or stiffeners.
- (b) Fractures at the connection between the longitudinals and the vertical stiffeners or brackets are to be cropped and the longitudinal part renewed if the fractures extend to over one third of the depth of the longitudinal. If fractures are not extensive they can be veed out and welded. In addition, reinforcement should be provided in the form of modification to existing bracket toes or the fitting of additional brackets with soft toes in order to reduce the stress concentration.
- (c) Fractures at the corners of the transverse diaphragm/stiffeners in the duct keel are to be cropped and renewed. In addition, scallops are to be closed by overlapping collar plates.
- (d) Fractures at the corners of the transverse web frame in the raised stringer decks are to be cropped and renewed. In addition, scallops are to be closed by overlapping collar plates.

**5.3.3** The bilge keel should be repaired as follows.

- (a) Fractures or distortion in bilge keels must be promptly repaired. Fractured butt welds should be repaired using full penetration welds and proper welding procedures. The bilge keel is subjected to the same level of longitudinal hull girder stress as the bilge plating and fractures in the bilge keel can propagate into the shell plating.
- (b) Termination of the bilge keel requires proper support by internal structure. This aspect should be taken into account when cropping and renewing damaged parts of a bilge keel (See **Example 11**).

**5.3.4** In the transition region, in order to reduce stress concentration due to discontinuity, the appropriate structure is to be provided in the contiguous space. If such a structure is not provided, or is deficient due to corrosion or misalignment, fractures may occur at the terminations.

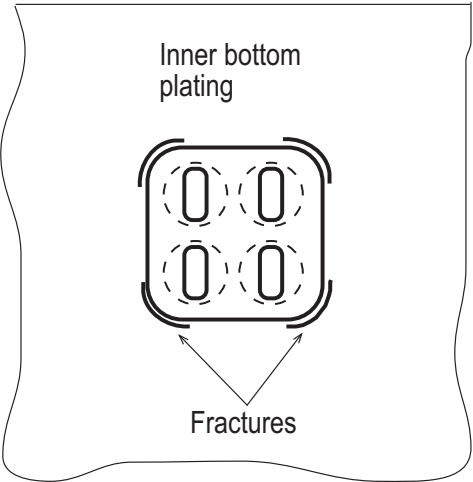
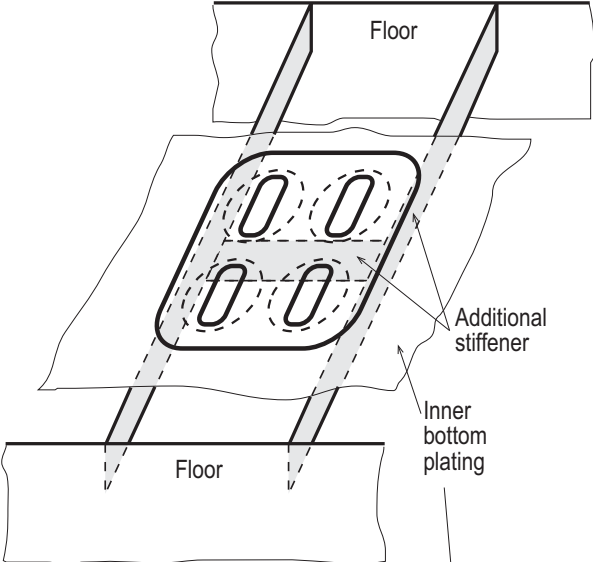
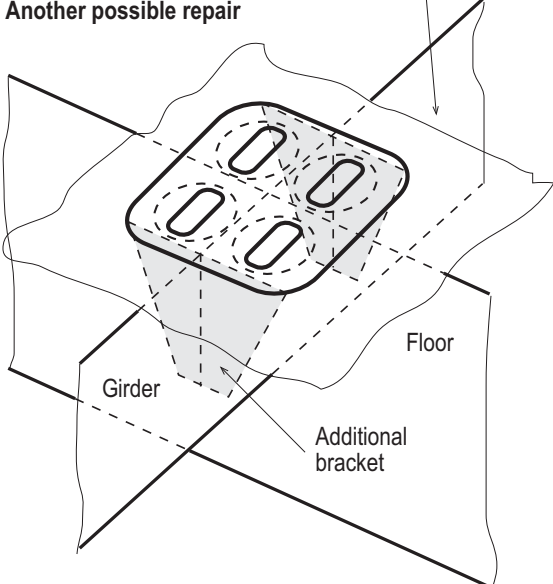

**No. 84**  
(cont)

<b>CONTAINER SHIPS</b>		<b>Guidelines for Surveys, Assessment and Repair of Hull Structure</b>	
<b>Part 1</b>	<b>Cargo hold region</b>	<b>Example No. 1</b>	
<b>Area 4</b>	<b>Double bottom tank structure</b>		
<b>Detail of damage</b>		Fractures in inner bottom plating around container bottom pocket	
<b>Sketch of damage</b>		<b>Sketch of repair</b>	
		<p><b>Most common repair</b></p>  <p><b>Another possible repair</b></p> 	
<b>Notes on possible cause of damage</b>		<b>Notes on repairs</b>	
<ol style="list-style-type: none"> <li>1. Pocket is not supported correctly by floor, longitudinal and/or stiffener.</li> </ol>		<ol style="list-style-type: none"> <li>1. Fractured plating should be cropped and part renewed.</li> <li>2. Adequate reinforcement should be considered.</li> </ol>	

**No. 84**  
(cont)

<b>CONTAINER SHIPS</b>		<b>Guidelines for Surveys, Assessment and Repair of Hull Structure</b>	
<b>Part 1</b>	<b>Cargo hold region</b>	<b>Example No. 2</b>	
<b>Area 4</b>	<b>Double bottom structure</b>		
<b>Detail of damage</b>		Fractures, corrosion and/or buckling of floor/girder around lightening hole	
<p><b>Sketch of damage</b></p> <p>Inner bottom plating</p> <p>Floor</p> <p>Lightening hole</p> <p>Bottom plating</p> <p>Fracture, thinning and/or buckling</p>		<p><b>Sketch of repair</b></p> <p><u>Repair A</u></p> <p>Add lug plate for fractured or buckled</p> <p>Doubling plate</p> <p><u>Repair B</u></p> <p>Add lug plate for fractured or buckled</p> <p>Faceplate</p> <p>Section A-A</p> <p><u>Repair C</u></p> <p>Add lug plate for fractured or buckled</p> <p>Carlings</p>	
<p><b>Notes on possible cause of damage</b></p> <ol style="list-style-type: none"> <li>1 Insufficient strength due to lightening hole.</li> <li>2 Fracture, corrosion and/or buckling around lightening hole due to high stress.</li> </ol>		<p><b>Notes on repairs</b></p> <ol style="list-style-type: none"> <li>1. Fractured, corroded and/or buckled plating should be cropped and renewed if considered necessary.</li> <li>2. Appropriate reinforcement should be considered.</li> </ol>	

No. 84  
(cont)

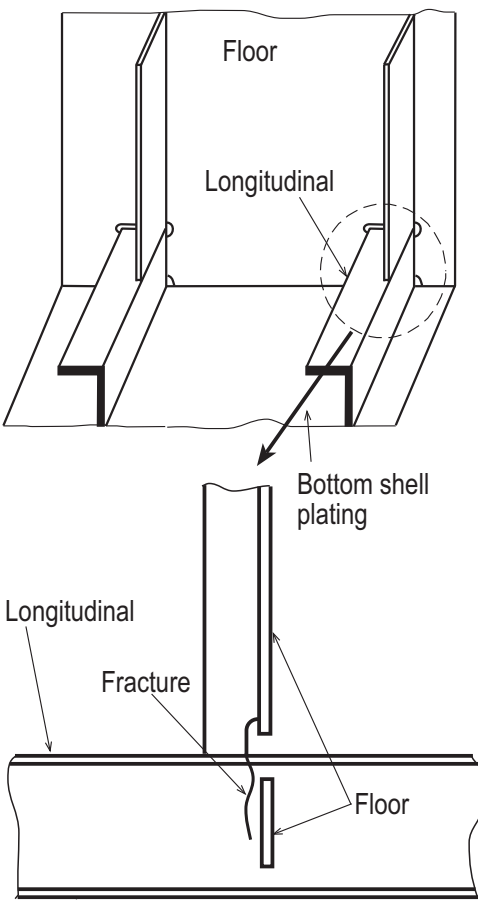
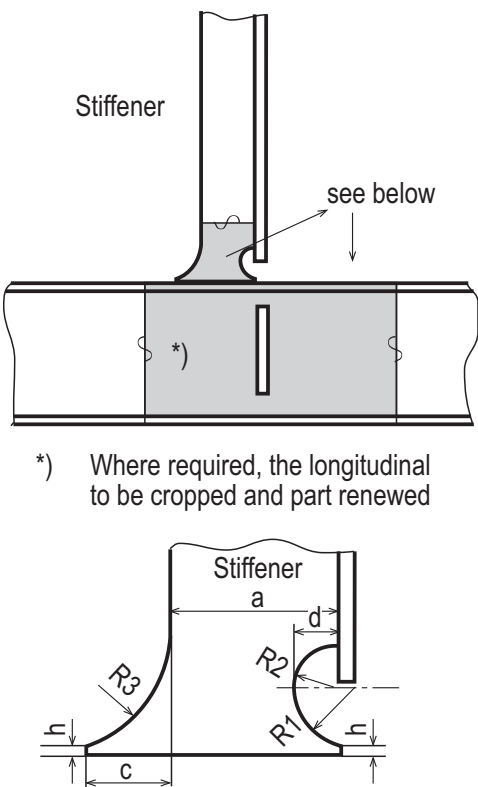
<b>CONTAINER SHIPS</b>		<b>Guidelines for Surveys, Assessment and Repair of Hull Structure</b>	
<b>Part 1</b>	<b>Cargo hold region</b>	<b>Example No. 3</b>	
<b>Area 4</b>	<b>Double bottom tank structure</b>		
<b>Detail of damage</b>		Fractures in longitudinal at floor or bulkhead	
<b>Sketch of damage</b>		<b>Sketch of repair</b>	
 <p>Note: same damage max occur at similar connection to inner bottom plating</p>		 <p>*) Where required, the longitudinal to be cropped and part renewed</p> <p>Various cut/out shapes have been developed. The following ist one example.</p> <ol style="list-style-type: none"> <li>1. Toe height as small as possible (h = 10 - 15 mm)</li> <li>2. Depth "d" of key hole notch as small a possible, max. 30 mm</li> <li>3. For a slope at toe max. 1 : 3</li> <li>4. <math>R1 = 1.5 d</math> <math>R2 = d</math> and <math>R3 = 1.5 c</math></li> </ol>	
<b>Notes on possible cause of damage</b>		<b>Notes on repairs</b>	
<ol style="list-style-type: none"> <li>1. Damage can be caused by stress concentrations leading to accelerated fatigue in this region.</li> </ol>		<ol style="list-style-type: none"> <li>1. If fractures extends to over one third of the depth of the longitudinal, then crop and part renew. Otherwise the fracture can be veed-out and welded.</li> </ol>	

# No. 84

(cont)

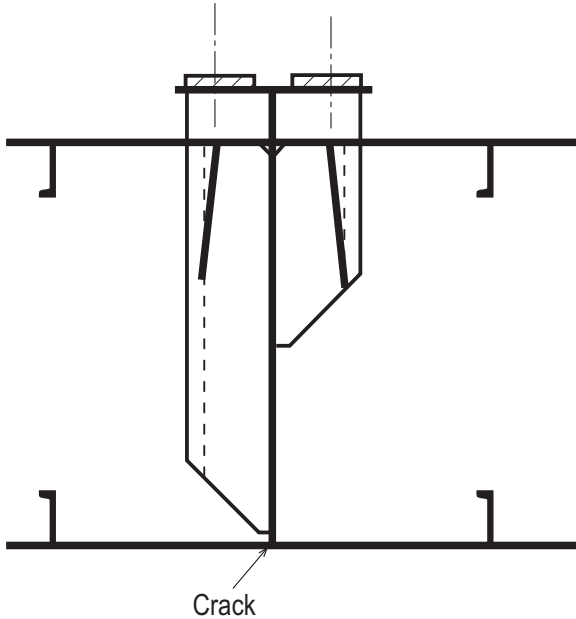
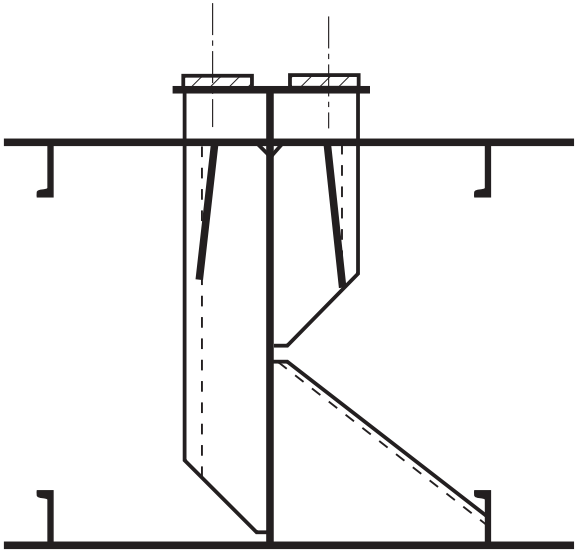
CONTAINER SHIPS		Guidelines for Surveys, Assessment and Repair of Hull Structure	
Part 1	Cargo hold region	Example No. 4	
Area 4	Double bottom tank structure		
<b>Detail of damage</b>		Fractures in longitudinal girders in way of container support	
<b>Sketch of damage</b>		<b>Sketch of repair</b>	
			
<b>Notes on possible cause of damage</b>		<b>Notes on repairs</b>	
<ol style="list-style-type: none"> <li>1. Damage can be caused by an insufficient strength of the longitudinal girder at the termination of the vertical stiffeners.</li> </ol> <p>The effect of a simultaneous occurrence of the tank pressure from one side and an asymmetrical load from the container sockets has not been taken into account.</p>		<ol style="list-style-type: none"> <li>1. Fractured part of the longitudinal girder has to be cropped and renewed by an insert.</li> <li>2. The lower part of the girder has to be supported by an additional transverse stiffener on the bottom shell plating.</li> </ol>	

**No. 84**  
(cont)

<b>CONTAINER SHIPS</b>		<b>Guidelines for Surveys, Assessment and Repair of Hull Structure</b>	
<b>Part 1</b>	<b>Cargo hold region</b>	<b>Example No. 5</b>	
<b>Area 4</b>	<b>Double bottom tank structure</b>		
<b>Detail of damage</b>	<b>Fractures in longitudinal in way of bilge well</b>		
<b>Sketch of damage</b>		<b>Sketch of repair</b>	
		<p>*) : Where required the longitudinals to be cropped and part renewed</p>	
<b>Notes on possible cause of damage</b>		<b>Notes on repairs</b>	
<p>1. Damage can be caused by stress concentrations leading to accelerated fatigue in this region.</p>		<p>1. If fractures are not extensive e.g. hairline fractures then these can be veed-out and welded.</p> <p>2. If the fracture extended to over one third of the depth of the longitudinal then crop and part renew.</p>	

**No. 84**  
(cont)

<b>CONTAINER SHIPS</b>		<b>Guidelines for Surveys, Assessment and Repair of Hull Structure</b>	
<b>Part 1</b>	<b>Cargo hold region</b>		<b>Example No. 6</b>
<b>Area 4</b>	<b>Double bottom tank structure</b>		
<b>Detail of damage</b>		Fractures in bottom shell or inner bottom plating at the corner drain hole/air hole in longitudinal	
<b>Sketch of damage</b>		<b>Sketch of repair</b>	
<p>The sketch shows a perspective view of a double bottom tank structure. A longitudinal beam is shown with a drain hole or air hole at its corner. Fractures are indicated at the corner of the drain hole. Labels include: Floor or transverse, Drain hole or air hole, Longitudinal, Fractures, and Bottom shell plating, or inner bottom plating. A second sketch below shows a cross-section of the bottom shell plating with a drain hole and fractures at the corner.</p>		<p>The sketch shows a cross-section of the bottom shell plating with a drain hole. A rectangular patch with a rounded drain hole shape is shown installed in the bottom shell plating, representing the repair.</p>	
<b>Notes on possible cause of damage</b>		<b>Notes on repairs</b>	
<ol style="list-style-type: none"> <li>1. Stress concentration and/or corrosion due to stress concentration at the corner of drain hole/air hole.</li> </ol>		<ol style="list-style-type: none"> <li>1. Fractured plating should be cropped and part renewed.</li> <li>2. If fatigue life is to be improved, change of drain hole/air hole shape is to be considered.</li> </ol>	

**No. 84**  
(cont)

<b>CONTAINER SHIPS</b>		<b>Guidelines for Surveys, Assessment and Repair of Hull Structure</b>	
<b>Part 1</b>	<b>Cargo hold region</b>	<b>Example No. 7</b>	
<b>Area 4</b>	<b>Double bottom tank structure</b>		
<b>Detail of damage</b>	Fractures in bottom plating alongside girder and/or bottom longitudinal		
<b>Sketch of damage</b>		<b>Sketch of repair</b>	
<b>Notes on possible cause of damage</b>		<b>Notes on repairs</b>	
<p>1. Vibration.</p>		<p>1. Fractured bottom shell plating should be cropped and renewed.</p> <p>2. Natural frequency of the panel should be changed, e.g. reinforcement by additional stiffener/bracket.</p>	

**No. 84**  
(cont)

<b>CONTAINER SHIPS</b>		<b>Guidelines for Surveys, Assessment and Repair of Hull Structure</b>	
<b>Part 1</b>	<b>Cargo hold region</b>	<b>Example No. 8</b>	
<b>Area 4</b>	<b>Double bottom tank structure</b>		
<b>Detail of damage</b>		Corrosion in bottom plating below suction head	
<b>Sketch of damage</b>		<b>Sketch of repair</b>	
		<ol style="list-style-type: none"> <li>1. Insert to have round corners</li> <li>2. Non-destructive examination to be applied after welding based on the Classification Society's rules</li> </ol>	
<b>Notes on possible cause of damage</b>		<b>Notes on repairs</b>	
<ol style="list-style-type: none"> <li>1. High flow rate associated with insufficient corrosion prevention system.</li> <li>2. Galvanic action between dissimilar metals.</li> </ol>		<ol style="list-style-type: none"> <li>1. Affected plating should be cropped and part renewed. Thicker plate and suitable beveling should be considered.</li> <li>2. If the corrosion is limited to a small area, i. e. pitting corrosion, repair by welding is acceptable.</li> </ol>	



**No. 84**  
(cont)

<b>CONTAINER SHIPS</b>		<b>Guidelines for Surveys, Assessment and Repair of Hull Structure</b>	
<b>Part 1</b>	<b>Cargo hold region</b>	<b>Example No. 9</b>	
<b>Area 4</b>	<b>Double bottom tank structure</b>		
<b>Detail of damage</b>		Corrosion in bottom plating below sounding pipe	
<b>Sketch of damage</b>		<b>Sketch of repair</b>	
		<p><b>Repair A</b></p> <p><b>Repair B</b></p>	
<b>Notes on possible cause of damage</b>		<b>Notes on repairs</b>	
<ol style="list-style-type: none"> <li>Accelerated corrosion of striking plate by the striking of the weight of the sounding tape.</li> </ol>		<ol style="list-style-type: none"> <li>Corroded bottom plating should be welded or partly cropped and renewed if considered necessary.</li> <li>Corroded striking plate should be renewed.</li> </ol>	

**No. 84**  
(cont)

<b>CONTAINER SHIPS</b>		<b>Guidelines for Surveys, Assessment and Repair of Hull Structure</b>	
<b>Part 1</b>	<b>Cargo hold region</b>	<b>Example No. 10</b>	
<b>Area 4</b>	<b>Double bottom tank structures</b>		
<b>Detail of damage</b>		Deformation of forward bottom shell plate due to slamming	
<b>Sketch of damage</b>		<b>Sketch of repair</b>	
<p>Shell expansion</p> <p>Deformation</p> <p>Collision bulkhead</p> <p>Flat line</p> <p>Keel plate</p> <p>Bottom shell plating</p> <p>No. 1 Water Ballast Tank</p> <p>Fore Peak Tank</p>		<p>Reinforcement of bottom shell plating by new stiffeners</p> <p>No. 1 Water Ballast Tank</p> <p>Fore Peak Tank</p>	
<b>Notes on possible cause of damage</b>		<b>Notes on repairs</b>	
<ol style="list-style-type: none"> <li>1. Heavy weather.</li> <li>2. Poor design for slamming.</li> <li>3. Poor operation, i.e. negligence of heavy ballast.</li> </ol>		<ol style="list-style-type: none"> <li>1. Deformed bottom shell plating should be faired in place, or partly cropped and renewed if considered necessary.</li> <li>2. Bottom shell plating should be reinforced by stiffeners.</li> </ol>	

No.  
84  
(cont)

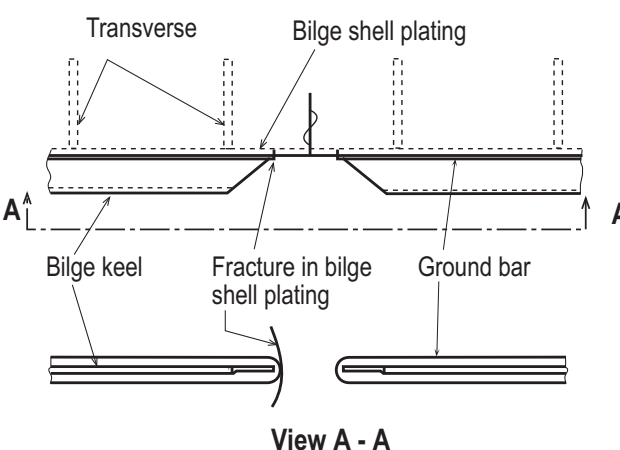
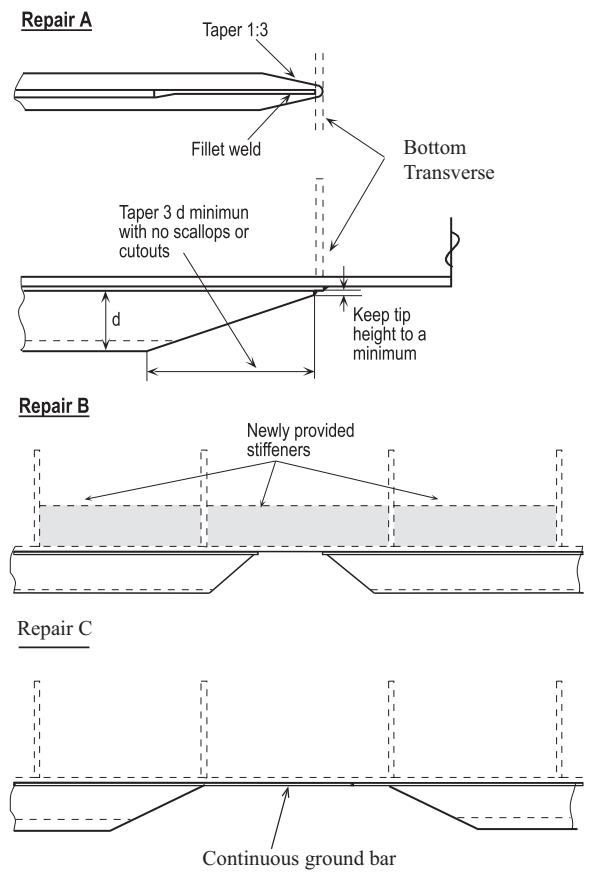
CONTAINER SHIPS		Guidelines for Surveys, Assessment and Repair of Hull Structure	
Part 1	Cargo hold region	Example No. 11	
Area 4	Double bottom structure		
<b>Detail of damage</b>		Fractures in shell plating at the termination of bilge keel	
<b>Sketch of damage</b>		<b>Sketch of repair</b>	
 <p>View A - A</p>			
<b>Notes on possible cause of damage</b>		<b>Notes on repairs</b>	
<ol style="list-style-type: none"> <li>Poor design causing stress concentration.</li> </ol>		<ol style="list-style-type: none"> <li>Fractured plating is to be cropped and renewed.</li> <li>Reduction of stress concentration of the bilge keel end should be considered. <ul style="list-style-type: none"> <li><b>Repair A:</b> Modification of the detail of end</li> <li><b>Repair B:</b> New internal stiffeners</li> <li><b>Repair C:</b> Continuous ground bar (in connection with <b>Repair A</b>)</li> </ul> </li> <li>Instead of <b>Repair A</b> or <b>B</b> continuous ground bar should be considered, also the bilge keel should be terminated at transverses or brackets.</li> </ol>	

No.  
84  
(cont)

<b>CONTAINER SHIPS</b>		<b>Guidelines for Surveys, Assessment and Repair of Hull Structure</b>	
<b>Part 1</b>	<b>Cargo hold region</b>	<b>Example No. 12</b>	
<b>Area 4</b>	<b>Double bottom structure</b>		
<b>Detail of damage</b>	Fracture in the tank top plate in way of the height transition of inner bottom		
<b>Sketch of damage</b>		<b>Sketch of repair</b>	
<b>Notes on possible cause of damage</b>		<b>Notes on repairs</b>	
<ol style="list-style-type: none"> <li>1. Insufficient strength of the sloping inner bottom plating in way of the knuckle;</li> <li>2. Stress concentration in way of the cut-out of the longitudinal girder.</li> </ol>		<ol style="list-style-type: none"> <li>1. Damaged tank top plate is to be cropped and renewed.</li> <li>2. Additional stiffeners are to be fitted near the knuckle of the slope inner bottom plates.</li> <li>3. The cut-out is to be closed with a thicker collar plate.</li> </ol>	

**No. Part 2 Fore and aft end regions**

**84**

(cont)

**Contents**

**Area 1 – Fore end structure**

**Area 2 – Aft end structure**

**Area 3 – Stern frame, rudder arrangement and propeller shaft supports**

## No. 84 Area 1 Fore end structures

84  
(cont)

### Contents

- 1 General
- 2 What to look for
  - 2.1 Material wastage
  - 2.2 Deformations
  - 2.3 Fractures
- 3 General comments on repair
  - 4.1 Material wastage
  - 4.2 Deformations
  - 4.3 Fractures

### Figures and/or Photographs – Area 1

No. Title

No.	Title
Figure 1	Fore end structure – Potential problem areas

### Examples of structural detail failures and repairs – Area 1

Example No. Title

Example No.	Title
1a	Deformation of forecastle deck (longitudinal stiffening system)
1b	Deformation of forecastle deck (transverse stiffening system)
2	Fractures in forecastle deck plating at the bulwark
3	Fractures in side bulkhead plating in way of chain locker
4	Deformation of side shell plating in way of forecastle space
5	Fracture and deformation of bow transverse web in way of cut-outs for side longitudinals
6	Fractures at toe of web frame bracket connection to stringer platform

**No.  
84**  
(cont)**1 General**

**1.1** Due to the high humidity salt water environment, wastage of the internal structure in the fore peak ballast tank can be a major problem for many, and in particular ageing ships. Corrosion of structure may be accelerated where the tank is not coated or where the protective coating has not been properly maintained, and can lead to fractures of the internal structures and the tank boundaries.

**1.2** In general container ships have a high power main engine and are operated to a tight schedule. Therefore, ships can proceed in comparatively heavy weather at a relatively high speed. In particular in the case of larger bow flare high local pressure due to bow flare slamming as well as increased global bending moments and shear forces in the fore end of the ship can cause hull damage such as deformations and fractures.

**1.3** Deformation can be caused by contact which can result in damage to the internal structure leading to fractures in the shell plating.

**1.4** Fractures of internal structure in the fore peak tank and spaces also result from wave impact load due to slamming and panting.

**1.5** The forecastle structure is exposed to green water and can suffer damage such as deformation of deck structures, deformation and fracture of bulwarks and collapse of masts, etc. Bulwarks are provided for the protection of the crew and of the anchor and mooring equipment. Due to the bow flare effect bulwarks are subject to impact forces which result in alternating tension and compression stresses which can cause fractures and corrosion at the bulwark bracket connections to the deck. These fractures may propagate to the deck plating and cause serious damage.

**1.6** The shell plating around the anchor and hawse pipe may suffer corrosion, deformation and possible fracture due to the movement of an improperly stowed and secured anchor, especially in the case of an unsheltered position as the same high hydrodynamic impact forces act on the anchor as on the hull structure, influencing the motion of the anchor in the hawse pipe.

**2 What to look for****2.1 Material wastage**

**2.1.1** Wastage (and possible subsequent fractures) is more likely to be initiated at the locations as indicated in **Figure 1** and particular attention should be given to these areas. A close-up survey should be carried out with selection of representative thickness measurements to determine the extent of corrosion.

**2.1.2** Structure in the chain locker is liable to heavy corrosion due to mechanical damage of the protective coating caused by the action of anchor chains. In some ships, especially smaller ships, the side shell plating may form boundaries of the chain locker and heavy corrosion may consequently result in holes in the side shell plating.

**2.2 Deformations**

**2.2.1** Contact with quay sides and other objects can result in large deformations and fractures of the internal structure. This may affect the watertight integrity of the tank boundaries and collision bulkhead. An examination of the damaged area should be carried out to determine the extent of the damage.

# No. 84

(cont)

## 2.3 Fractures

2.3.1 Fractures in the fore peak tank are normally found by inspection of the internal structure.

2.3.2 Fractures are often found in the transition region and reference should be made to **Part 1, Area 2**.

2.3.3 Fractures that extend through the thickness of the plating or through the boundary welds may be observed during pressure testing of tanks.

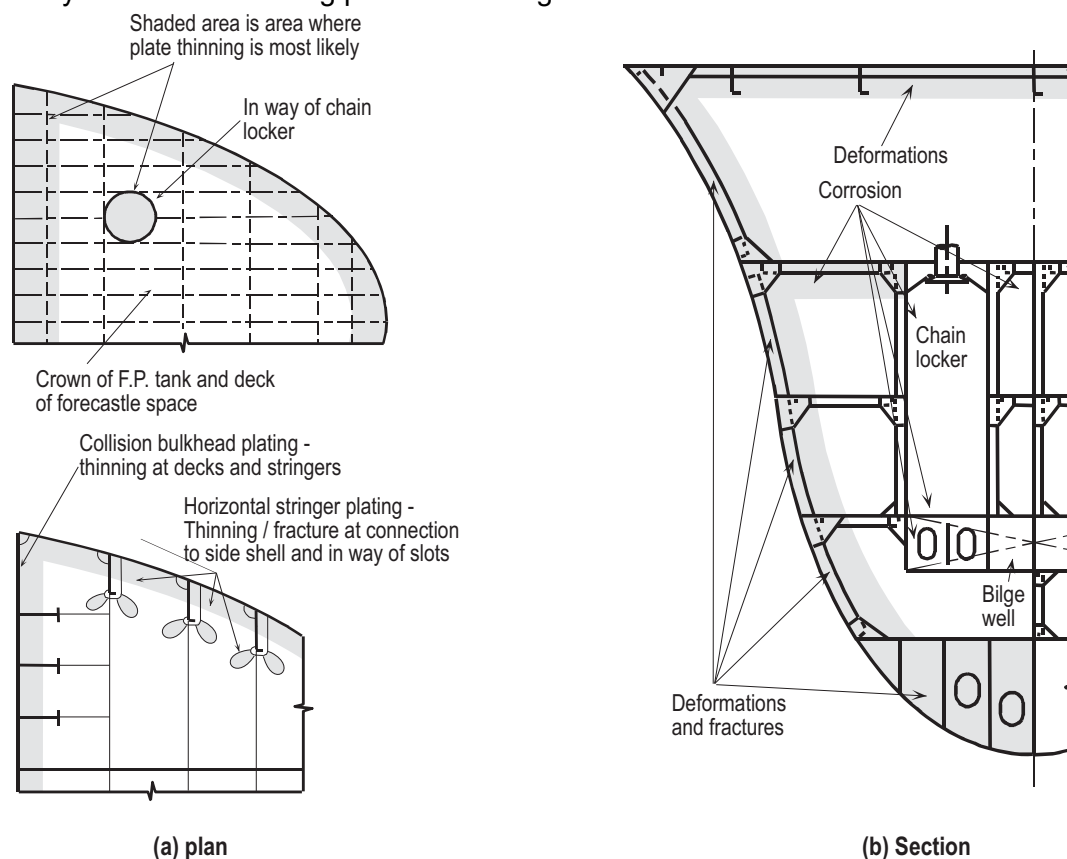

**Fig 1 Fore end structure - Potential problem areas**

## 3 General comments on repair

### 3.1 Material wastage

3.1.1 The extent of steel renewal required can be established based on representative thickness measurements. Where part of the structure has deteriorated to the permissible minimum thickness, then the affected area is to be cropped and renewed. Repair work in tanks requires careful planning in terms of accessibility.

### 3.2 Deformations

3.2.1 Deformed structure caused by contact should be cropped and part renewed or faired in place depending on the nature and extent of damage.



**No. 84**  
(cont)

**3.3 Fractures**

3.3.1 Fractures of a minor nature may be veed-out and rewelded. Where cracking is more extensive, the structure is to be cropped and renewed. In the case of fractures caused by sea loads, increased thickness of plating and/or design modification to reduce stress concentrations should be considered (See **Examples 1a, 1b, 2 and 6**).

<b>CONTAINER SHIPS</b>		<b>Guidelines for Surveys, Assessment and Repair of Hull Structure</b>	
<b>Part 2</b>	<b>Fore and aft end regions</b>		<b>Example No.</b>
<b>Area 1</b>	<b>Fore end structure</b>		<b>1a</b>
<b>Detail of damage</b>	<b>Deformation of forecastle deck (longitudinal stiffening system)</b>		
<b>Sketch of damage</b>		<b>Sketch of repair</b>	
<p>○: Dent in deck plating Hawse pipe Fore-castle deck Buckling Side shell plate</p>		<p>□: Insert plate Newly provided collar plate Part renewal of longitudinal Part renewal of web plate Newly provided stiffener</p>	
<b>Notes on possible cause of damage</b>		<b>Notes on repairs</b>	
<ol style="list-style-type: none"> <li>Green sea on deck.</li> <li>Insufficient strength.</li> </ol>		<ol style="list-style-type: none"> <li>Deformed structure should be cropped and renewed.</li> <li>Additional stiffeners on web of beam should be considered for reinforcement.</li> </ol>	

No. 84  
(cont)

<b>CONTAINERSHIP</b>		<b>Guidelines for Surveys, Assessment and Repair of Hull Structure</b>	
<b>Part 2</b>	<b>Fore and aft end regions</b>	<b>Example No. 1-b</b>	
<b>Area 1</b>	<b>Fore end structure</b>		
<b>Detail of damage</b>		<b>Deformation of forecastle deck (transverse stiffening system)</b>	
<b>Sketch of damage</b>		<b>Sketch of repair</b>	
<b>Notes on possible cause of damage</b>		<b>Notes on repairs</b>	
<ol style="list-style-type: none"> <li>Green sea on deck and bow flare impact pressure.</li> <li>Insufficient strength.</li> </ol>		<ol style="list-style-type: none"> <li>Deformed structure should be cropped and renewed. Plate thickness of the deck plating should be increased.</li> <li>Additional longitudinal stiffeners parallel to the longitudinal girders. Openings in the web should be closed by collar plates.</li> </ol>	

**No. 84**  
(cont)

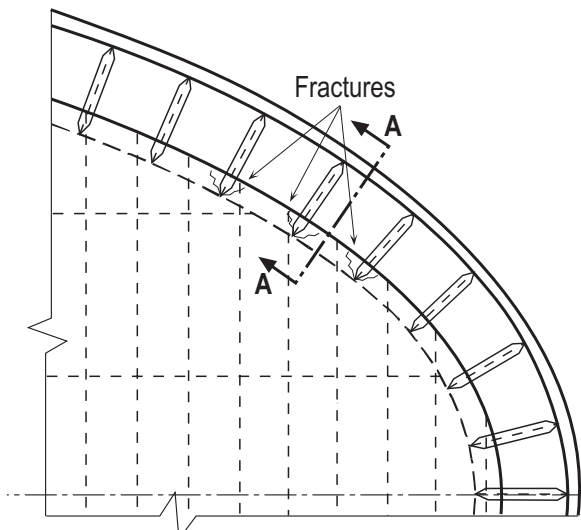
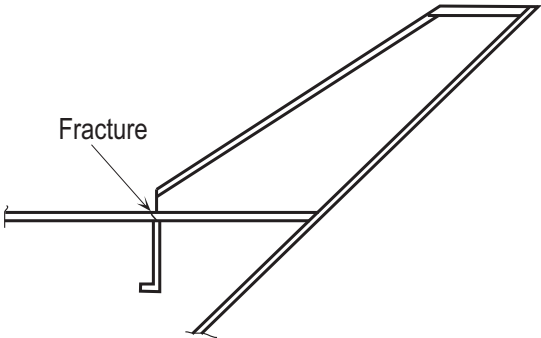
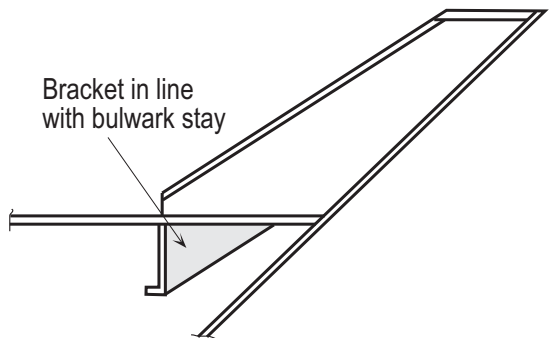
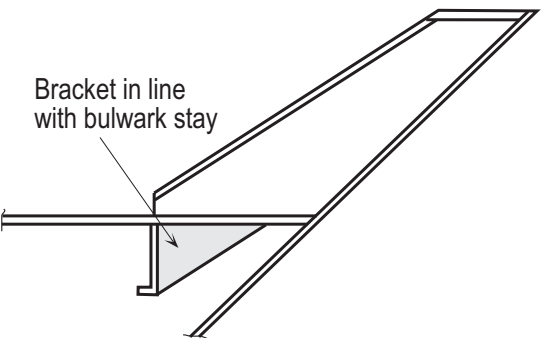
<b>CONTAINER SHIPS</b>		<b>Guidelines for Surveys, Assessment and Repair of Hull Structure</b>	
<b>Part 2</b>	<b>Fore and aft end regions</b>	<b>Example No. 2</b>	
<b>Area 1</b>	<b>Fore end structure</b>		
<b>Detail of damage</b>	Fractures in forecastle deck plating at bulwark		
<b>Sketch of damage</b>		<b>Sketch of repair</b>	
  <p style="text-align: center;">View A - A</p>		  <p style="text-align: center;">View A - A</p>	
<b>Notes on possible cause of damage</b>		<b>Notes on repairs</b>	
<ol style="list-style-type: none"> <li>1. Bow flare effect in heavy weather.</li> <li>2. Stress concentration due to poor design.</li> </ol>		<ol style="list-style-type: none"> <li>1. Fractured deck plating should be cropped and renewed.</li> <li>2. Bracket in line with the bulwark stay to be fitted to reduce stress concentration.</li> </ol>	

**No. 84**  
(cont)

<b>CONTAINER SHIPS</b>		<b>Guidelines for Surveys, Assessment and Repair of Hull Structure</b>	
<b>Part 2</b>	<b>Fore and aft end regions</b>	<b>Example No. 3</b>	
<b>Area 1</b>	<b>Fore end structure</b>		
<b>Detail of damage</b>		Fractures in side in bulkhead plating way of chain locker	
<b>Sketch of damage</b>		<b>Sketch of repair</b>	
<b>Notes on possible cause of damage</b>		<b>Notes on repairs</b>	
<ol style="list-style-type: none"> <li>1. Heavy corrosion in region where mud is accumulated.</li> </ol>		<ol style="list-style-type: none"> <li>1. Corroded plating should be cropped and renewed.</li> <li>2. Protective coating should be applied.</li> </ol>	

**No. 84**  
(cont)

<b>CONTAINER SHIPS</b>		<b>Guidelines for Surveys, Assessment and Repair of Hull Structure</b>	
<b>Part 2</b>	<b>Fore and aft end regions</b>	<b>Example No. 4</b>	
<b>Area 1</b>	<b>Fore end structure</b>		
<b>Detail of damage</b>		Deformation of side shell plating in way of forecastle space	
<b>Sketch of damage</b>		<b>Sketch of repair</b>	
<p>Side shell plating in way of forecastle space</p> <p>Forecastle deck</p> <p>Side shell frames/stiffeners</p> <p>Deck</p> <p>Side shell frame</p> <p>⊘: Buckling</p> <p>View A - A</p>		<p><b>Repair A</b></p> <p>⊘ Newly provided intercostal stiffeners</p> <p><b>Repair B</b></p> <p>⊘ Insertion of plate of increased thickness</p>	
<b>Notes on possible cause of damage</b>		<b>Notes on repairs</b>	
<ol style="list-style-type: none"> <li>1. Heavy weather.</li> <li>2. Insufficient strength.</li> </ol>		<ol style="list-style-type: none"> <li>1. Deformed part should be cropped and part renewed.</li> <li>2. <b>Repair A</b> Additional stiffeners between existing stiffeners should be considered.</li> </ol> <p><b>Repair B</b> Insertion of plate of increased thickness without additional stiffeners.</p>	

**No. 84**  
(cont)

<b>CONTAINER SHIPS</b>		<b>Guidelines for Surveys, Assessment and Repair of Hull Structure</b>	
<b>Part 2</b>	<b>Fore and aft end regions</b>		<b>Example No. 5</b>
<b>Area 1</b>	<b>Fore end structure</b>		<b>5</b>
<b>Detail of damage</b>		Fracture and deformation of bow transverse web in way of cut-outs for side longitudinals	
<b>Sketch of damage</b>		<b>Sketch of repair</b>	
<b>Notes on possible cause of damage</b>		<b>Notes on repairs</b>	
<ol style="list-style-type: none"> <li>1. Localized material wastage in way of coating failure at cut-outs and sharp edges due to working of the structure.</li> <li>2. Dynamic seaway loading in way of bow flare.</li> </ol>		<ol style="list-style-type: none"> <li>1. Sufficient panel strength to be provided to absorb the dynamic loads enhanced by bow flare shape.</li> </ol>	

No.  
84

(cont)

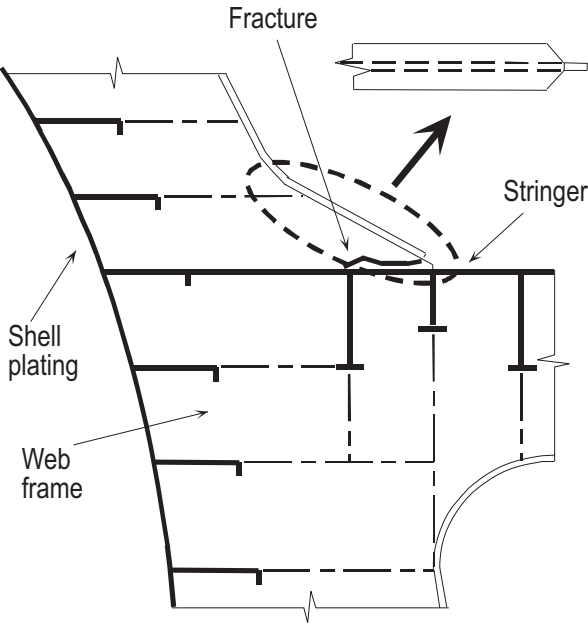
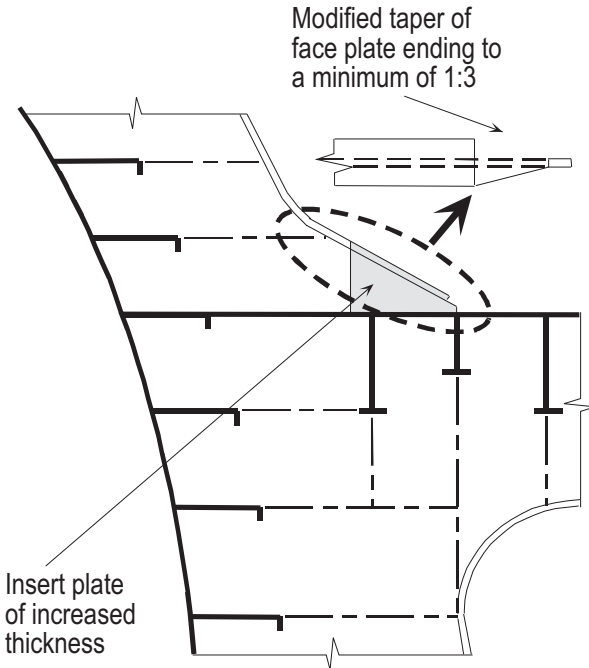
CONTAINER SHIPS		Guidelines for Surveys, Assessment and Repair of Hull Structure	
Part 2	Fore and aft end regions		Example No.
Area 1	Fore end structure		6
<b>Detail of damage</b>		Fractures at toe of web frame bracket connection to stringer platform	
<b>Sketch of damage</b>		<b>Sketch of repair</b>	
			
<b>Notes on possible cause of damage</b>		<b>Notes on repairs</b>	
<ol style="list-style-type: none"> <li>1. Inadequate bracket forming the web frame connection to the stringer.</li> <li>2. Localized material wastage in way of coating failure at bracket due to flexing of the structure.</li> <li>3. Dynamic seaway loading in way of bow flare.</li> </ol>		<ol style="list-style-type: none"> <li>1. Adequate soft nose bracket endings with a face plate taper of at least 1:3 to be provided.</li> </ol>	

## No. 84 Area 2 Aft end structures

84  
(cont)

### Contents

- 1 General
- 2 What to look for
  - 2.1 Material wastage
  - 2.2 Deformations
  - 2.3 Fractures
- 3 General comments on repair
  - 3.1 Material wastage
  - 3.2 Deformations
  - 3.3 Fractures

### Figures and/or Photographs – Area 2

No.	Title
Figure 1	Aft end structure – Potential problem areas

### Examples of structural detail failures and repairs – Area 2

Example No.	Title
1	Fractures in bulkhead in way of rudder trunk
2	Fractures at the connection of floors and girder/side brackets
3-a	Fractures in the steering gear flat by the rudder carrier
3-b	Fractures in steering gear foundation brackets and deformed deck plate



**No.  
84**  
(cont)**1 General**

**1.1** Due to the high humidity salt water environment, wastage of the internal structure in the aft peak ballast tank can be a major problem for many, and in particular ageing, ships. Corrosion of structure may be accelerated where the tank is not coated or where the protective coating has not been properly maintained, and can lead to fractures of the internal structure and the tank boundaries.

**1.2** Deformation can be caused by contact or wave impact action from astern (which can result in damage to the internal structure leading to fractures in the shell plating).

**1.3** Fractures to the internal structure in the aft peak tank and spaces can also result from main engine and propeller excited vibration.

**2 What to look for****2.1 Material wastage**

**2.1.1** Wastage (and possible subsequent fractures) is more likely to be initiated at the locations as indicated in **Figure 1**. An inspection should be carried out with a selection of representative thickness measurements to determine the extent of corrosion. Particular attention should be given to bunker tank boundaries and spaces adjacent to the hot engine room.

**2.2 Deformations**

**2.2.1** Contact with quay sides and other objects can result in large deformations and fractures of the internal structure. This may affect the watertight integrity of the tank boundaries and bulkheads. An examination of the deformed area should be carried out to determine the extent of the damage.

**2.3 Fractures**

**2.3.1** Fractures in welds at floor connections and other locations in the aft peak tank and rudder tank space can normally only be found by inspection.

**2.3.2** The structure supporting the rudder carrier may fracture and/or deform due to excessive loads on the rudder. Bolts connecting the rudder carrier to the steering gear flat may also suffer damage under such loads.

# No. 84 (cont)

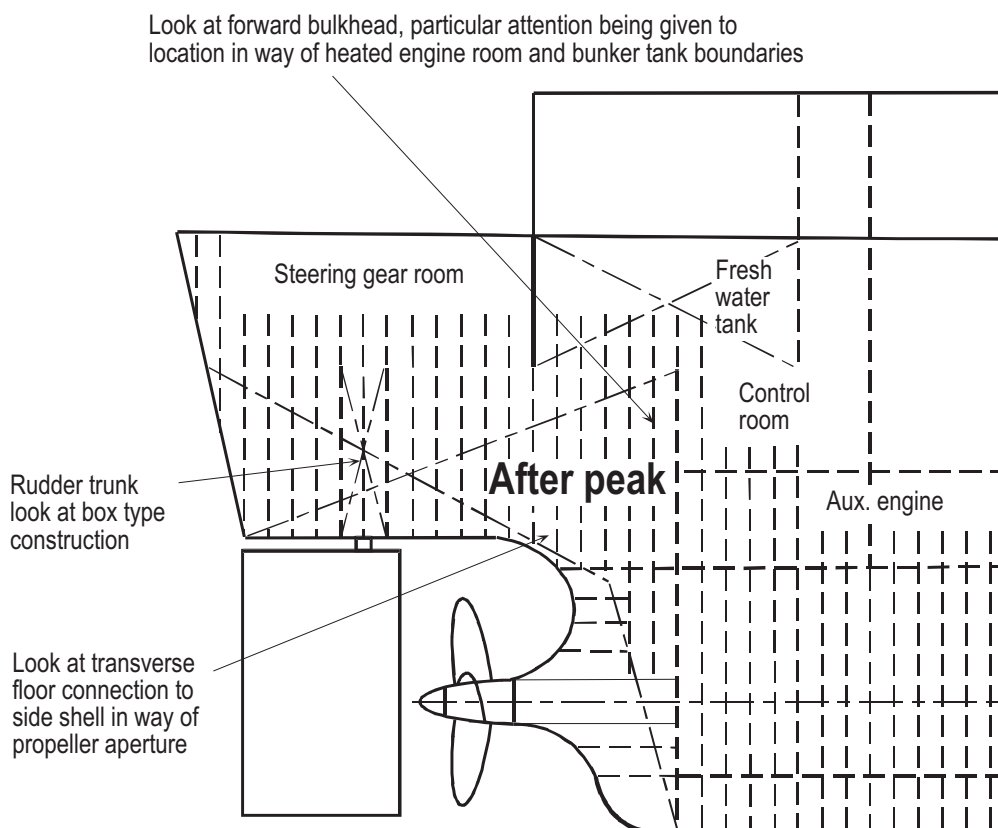

**Figure 1 Aft end structure – Potential problem areas**

### 3 General comments on repair

#### 3.1 Material wastage

**3.1.1** The extent of steel renewal required can be established based on representative thickness measurements. Where part of the structure has deteriorated to the permissible minimum thickness, then the affected area is to be cropped and renewed. Repair work in tanks requires careful planning in terms of accessibility.

#### 3.2 Deformations

**3.2.1** Deformed structure caused by contact should be cropped and part renewed or faired in place, depending on the extent of damage.

#### 3.3 Fractures

**3.3.1** Fractures of a minor nature may be veed-out and rewelded. Where cracking is more extensive, the structure is to be cropped and renewed.

**3.3.2** In order to prevent recurrence of damages suspected to be caused by main engine or propeller excited vibration, the cause of the vibration should be ascertained and additional reinforcements should be provided as found necessary (See **Examples 1** and **2**).

**3.3.3** In the case of fractures caused by sea loads, increased thickness of plating and/or design modifications to reduce stress concentrations should be considered.

**3.3.4** Fractured structure which supports the rudder carrier is to be cropped, and renewed, and may have to be reinforced (See **Examples 3-a** and **3-b**).

No. 84  
(cont)

<b>CONTAINER SHIPS</b>		<b>Guidelines for Surveys, Assessment and Repair of Hull Structure</b>	
<b>Part 2</b>	<b>Fore and aft end regions</b>		<b>Example No. 1</b>
<b>Area 2</b>	<b>Aft end structure</b>		<b>1</b>
<b>Detail of damage</b>		<b>Fractures in bulkhead in way of rudder trunk</b>	
<b>Sketch of damage</b>		<b>Sketch of repair</b>	
<b>Notes on possible cause of damage</b>		<b>Notes on repairs</b>	
<p>1. Vibration.</p>		<p>1. The fractured plating should be cropped and renewed.</p> <p>2. Natural frequency of the plate between stiffeners should be changed, e.g. reinforcement by additional stiffeners.</p>	

**No. 84**  
(cont)

<b>CONTAINER SHIPS</b>		<b>Guidelines for Surveys, Assessment and Repair of Hull Structure</b>	
<b>Part 2</b>	<b>Fore and aft end regions</b>	<b>Example No. 2</b>	
<b>Area 2</b>	<b>Aft end structure</b>		
<b>Detail of damage</b>		<b>Fractures at the connection of floors and girders/side brackets</b>	
<b>Sketch of damage</b>		<b>Sketch of repair</b>	
<p>A.P.T.</p> <p>Rudder trunk</p> <p>↓:Fracture</p> <p>View A - A</p>		<p>Newly provided angle</p>	
<b>Notes on possible cause of damage</b>		<b>Notes on repairs</b>	
<ol style="list-style-type: none"> <li>Vibration.</li> </ol>		<ol style="list-style-type: none"> <li>The fractured plating should be cropped and renewed.</li> <li>Natural frequency of the panel should be changed, e.g. reinforcement by additional strut.</li> </ol>	

**No. 84**  
(cont)

<b>CONTAINER SHIPS</b>		<b>Guidelines for Surveys, Assessment and Repair of Hull Structure</b>	
<b>Part 2</b>	<b>Fore and aft end regions</b>		<b>Example No. 3-a</b>
<b>Area 2</b>	<b>Aft end structure</b>		
<b>Detail of damage</b>		Fractures in flat where rudder carrier is installed in steering gear room	
<b>Sketch of damage</b>		<b>Sketch of repair</b>	
<p>Steering gear flat</p> <p>Rudder trunk</p> <p>View A - A</p> <p>Steering gear flat</p> <p>Fractures</p> <p>A</p> <p>A</p>		<p>Additional brackets</p> <p>Additional stiffening ring</p> <p>View B - B</p> <p>B</p> <p>B</p>	
<b>Notes on possible cause of damage</b>		<b>Notes on repairs</b>	
<ol style="list-style-type: none"> <li>Inadequate design.</li> </ol>		<ol style="list-style-type: none"> <li>Fractured plating should be cropped and renewed.</li> <li>Additional brackets and stiffening ring should be fitted for reinforcement.</li> </ol>	

**No. 84**  
(cont)

CONTAINER SHIPS		Guidelines for Surveys, Assessment and Repair of Hull Structure	
Part 2	Fore and aft end regions	Example No. 3-b	
Area 2	Aft end structure		
Detail of damage	Fractures in steering gear foundation brackets and deformed deck plate		
<p><b>Sketch of damage</b></p> <p>View B - B</p> <p>Fractures View A - A</p> <p>Bracket</p> <p>Buckling</p> <p>Watertight bulkhead</p>		<p><b>Sketch of repair</b></p> <p>View C - C</p> <p>New insert plate of increased thickness</p> <p>Increased bracket</p> <p>Additional stiffening</p> <p>Additional bracket</p>	
<p><b>Notes on possible cause of damage</b></p> <ol style="list-style-type: none"> <li>1. Insufficient deck strengthening (missing base plate).</li> <li>2. Insufficient strengthening of steering gear foundation.</li> <li>3. Bolts of steering gear were not sufficiently pre-loaded.</li> </ol>		<p><b>Notes on repairs</b></p> <ol style="list-style-type: none"> <li>1. New insert base plate of increased plate thickness.</li> <li>2. Additional longitudinal stiffening at base plate edges.</li> <li>3. Additional foundation brackets above and under deck (star configuration).</li> </ol>	

# No. 84 Area 3 Stern frame, rudder arrangement and propeller shaft support

(cont)

## Contents

- 1 General
- 2 What to look for
  - 2.1 Deformations
  - 2.2 Fractures
  - 2.3 Corrosion/Erosion/Abrasion
- 3 General comments on repair
  - 3.1 Rudder stock and pintles
  - 3.2 Plate structure
  - 3.3 Abrasion of bush and sleeve
  - 3.4 Assembling of rudders
  - 3.5 Repair of propeller boss and stern tube

## Figures and/or Photographs – Area 3

No.	Title
Figure 1	Nomenclature for stern frame, rudder arrangement and propeller shaft support
Figure 2	Potential problem areas
Photograph 1	Fractured rudder
Figure 3	Rudder stock repair by welding
Diagram 1	Preheating temperature

## Examples of structural detail failures and repairs – Area 3

Example No.	Title
1	Fractures in rudder horn along bottom shell plating
2	Fractures in rudder stock
3	Fractures in connection of palm plate to rudder blade
4	Fractures in rudder plating of semi-spade rudder (short fractures with end located forward of the vertical web)
5	Fractures in rudder plating of semi-spade rudder extending beyond the vertical web
6	Fractures in rudder plating of semi-spade rudder in way of pintle cutout
7	Fractures in side shell plating at the connection to propeller boss
8	Fractures in stern tube at the connection to stern frame

**No.  
84**  
(cont)**1 General**

- 1.1** The stern frame, strut bearing arrangement (if fitted) and connecting structures are exposed to propeller induced vibrations, which may lead to fatigue cracking in areas where stress concentrations occur.
- 1.2** The rudder and rudder horn are exposed to an accelerated and fluctuating stream from the propeller, which may also lead to fatigue cracking in areas where stress concentrations occur.
- 1.3** In extreme weather conditions the rudder may suffer wave slamming forces causing deformations of rudder stock and rudder horn as well as of the rudder itself.
- 1.4** The rudder and rudder horn as well as struts (on a shafting arrangement with strut bearings) may also come into contact with floating objects such as logs of timber or ice causing damages similar to those described in **1.3**.
- 1.5** Since different materials are used in adjacent compartments and structures, accelerated (galvanic) corrosion may occur if protective coatings and/or sacrificial anodes are not maintained properly.
- 1.6** Pre-existing manufacturing internal defects in cast pieces may lead to fatigue cracking.
- 1.7** A summary of potential problem areas is shown in **Figure 2**.
- 1.8** The mounting process of the rudder after dismantling and repair needs special attention in order to prevent deficiencies that might occur in the future
- 1.9** A complete survey of the rudder arrangement is only possible in drydock. However, in some cases a survey including a damage survey can be carried out afloat by divers or with a trimmed ship.



No.  
84  
(cont)

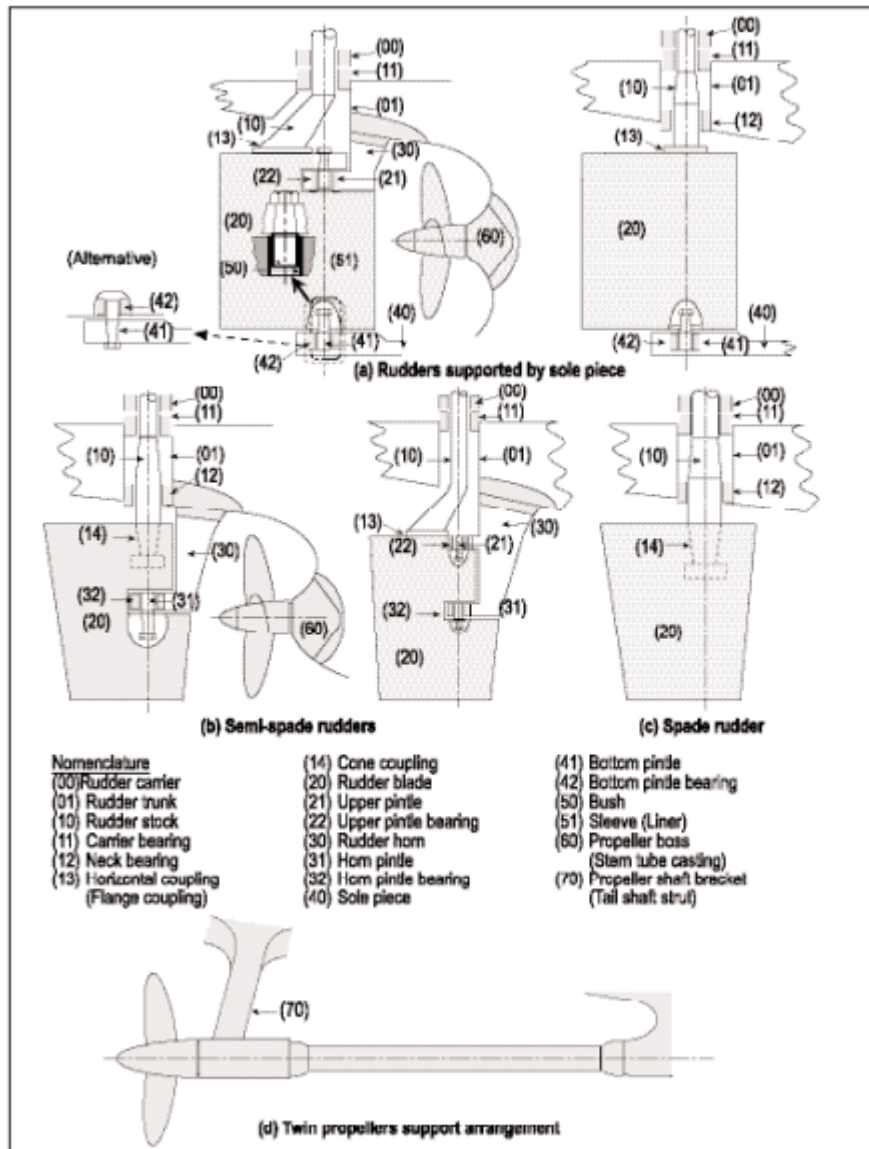

**Figure 1 Nomenclature for stern frame, rudder arrangement and propeller shaft support**

**No.  
84**  
(cont)

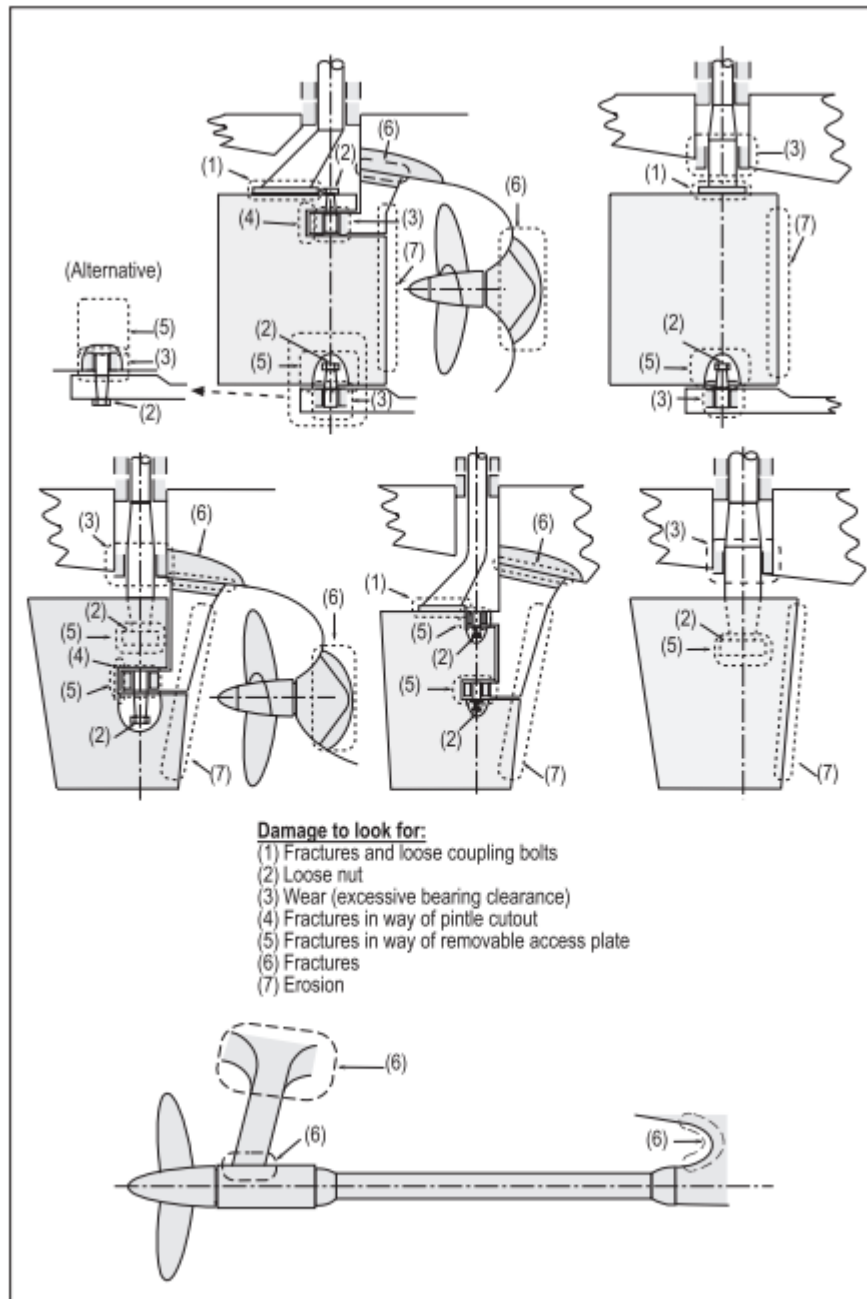

**Figure 2 Potential problem areas**

**No.  
84**  
(cont)**2 What to look for – Drydock inspection****2.1 Deformations**

**2.1.1** Rudder blade, rudder stock, rudder horn, sole piece and propeller boss/brackets have to be checked for deformations.

**2.1.2** Excessive clearance could be an indication of deformation of rudder stock/rudder horn.

**2.1.3** Possible twisting, deformation or slipping of the cone connection can be observed by the difference in angle between rudder and tiller.

**2.1.4** If bending or twisting deformation is found, the rudder has to be dismantled for further inspection.

**2.2 Fractures**

**2.2.1** Fractures in rudder plating should be looked for at slot welds and welds of the access plate of the vertical cone coupling between the rudder blade and rudder stock and/or pintle. Such welds may have latent defects due to the limited applicable welding procedure. Serious fractures in rudder plating may cause the loss of the rudder.

**2.2.2** Fractures should be looked for at weld connections between the rudder horn, propeller boss and propeller shaft brackets, and stern frame.

**2.2.3** Fractures should be looked for at the upper and lower corners in way of the pintle recess in case of semi-spade rudders. Typical fractures are shown in **Examples 4** and **5**.

**2.2.4** Fractures should be looked for at the transition radius between the rudder stock and horizontal coupling (palm) plate, and the connection between the horizontal coupling plate and rudder blade in the case of horizontal coupling. Typical fractures are shown in **Examples 2** and **3**. Fatigue fractures should be looked for at the palm plate itself in case of loosened or lost coupling bolts.

**2.2.5** Fractures should be looked for in the rudder plating in way of the internal stiffening structures since (resonant) vibrations of the plating may have occurred.

**2.2.6** If the rudder stock is deformed, fractures should be looked for in the rudder stock by nondestructive examinations before commencing repair measures, in particular in and around the keyway, if any.

**No.  
84**  
(cont)**2.3 Corrosion/Erosion/Abrasion**

**2.3.1** Corrosion/erosion (such as deep pitting corrosion) should be looked for in rudder/rudder horn plating, especially in welds. In extreme cases the corrosion /erosion may cause a large fracture as shown in

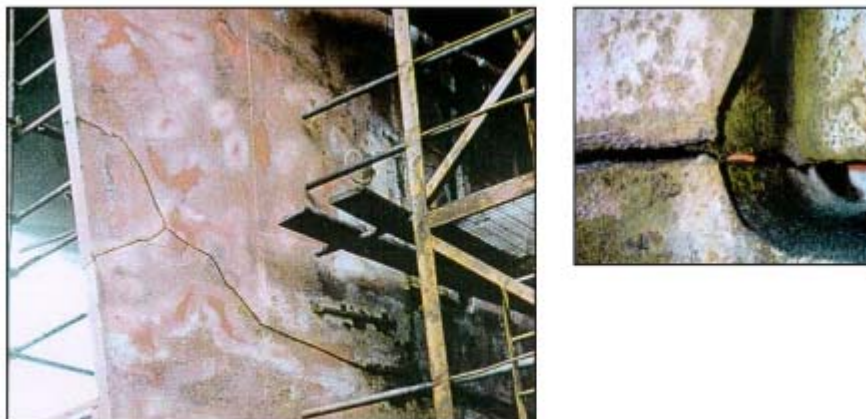
**Photograph 1.**

**Photograph 1 Fractured rudder**

**2.3.2** The following should be looked for on rudder stock and pintle:

- excessive clearance between the sleeve and bush of the rudder stock/pintle beyond the allowable limit specified by the Classification Society.
- condition of sleeve. If the sleeve is loose, ingress of water may have caused corrosion.
- deep pitting corrosion in the rudder stock and pintle adjacent to the stainless steel sleeve.
- slipping of rudder stock cone coupling. For a vertical cone coupling with hydraulic pressure connection, sliding of the rudder stock cone in the cast piece may cause severe surface damage.
- where a stainless steel liner/sleeve/cladding for the pintle/rudder stock is fitted into a stainless steel bush, an additional check should be made for crevice corrosion.

**3 General comments on repair****3.1 Rudder stock and pintles**

**3.1.1** If the rudder stock is twisted due to excessive forces such as contact or grounding and has no additional damage (fractures etc.) or other significant deformation, the stock usually can be used. The need for repair or heat treatment of the stock will depend on the amount of twist in the stock according to the requirements of the Classification Society. The keyway, if any, has to be milled in a new position.

**No.  
84**  
(cont)

**3.1.2** Rudder stocks with bending deformations, not having any fractures, may be repaired, depending on the size of the deformation, either by warm or by cold straightening in an approved workshop according to a procedure approved by the Classification Society. In case of warm straightening, as a guideline, the temperature should usually not exceed the heat treatment temperature of 530-580°C.

**3.1.3** In the case of fractures to a rudder stock with deformations, the stock may be used again depending on the nature and extent of the fractures. If a welding repair is considered acceptable, the fractures are to be removed by machining/grinding and the welding is to be based on an approved welding procedure together with post weld heat treatment as required by the Classification Society.

**3.1.4** Rudder stocks and/or pintles may be repaired by welding replacing wasted material by similar weld material provided its chemical composition is suitable for welding, i.e. the carbon content must usually not exceed 0.25%. The welding procedures are to be identified as a function of the carbon equivalent (Ceq). After removal of the wasted area (corrosion, scratches, etc.) by machining and/or grinding the build-up welding has to be carried out by an automatic spiral welding according to an approved welding procedure. The welding has to be extended over the area of large bending moments (rudder stocks). In special cases post weld heat treatment has to be carried out according to the requirements of the Classification Society. After final machining, a sufficient number of layers of welding material have to remain on the rudder stock/pintle. A summary of the most important steps and conditions of this repair is shown in the **Figure 3**.

**3.1.5** In the case of rudder stocks with bending loads, fatigue fractures in way of the transition radius between the rudder stock and the horizontal coupling plate cannot be repaired by local welding. A new rudder stock with a modified transition geometry has to be manufactured, as a rule (See **Example 2**). In exceptional cases a welding repair can be carried out based on an approved welding procedure. Measures have to be taken to avoid a coincidence of the metallurgical notch of the heat affected zone with the stress concentration in the radius area. Additional surveys of the repair (including non-destructive fracture examination) have to be carried out in reduced intervals.

# No. 84

(cont)

## Replacing wasted material by similar ordinary weld material

- Removal of the wasted area by machining and/or grinding, non-destructive examination for fractures (magnetic particle inspection preferred)
- Build-up welding by automatic spiral welding (turning device) according to an approved welding procedure (weld process, preheating, welding consumables, etc.)
- Extension of build-up welding over the area of **large bending moments (shafts)** according to the sketch

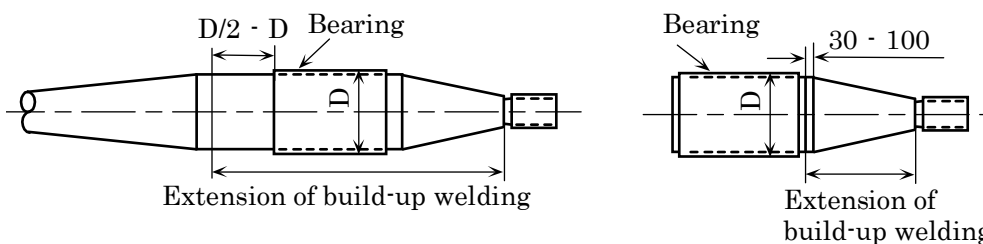

**Rudder stock**

**Pintle**

- Sufficient number of weld layers to compensate removed material, at least one layer in excess (heat treatment of the remaining layer)
- Transition at the end of the build-up welding according to the following sketch

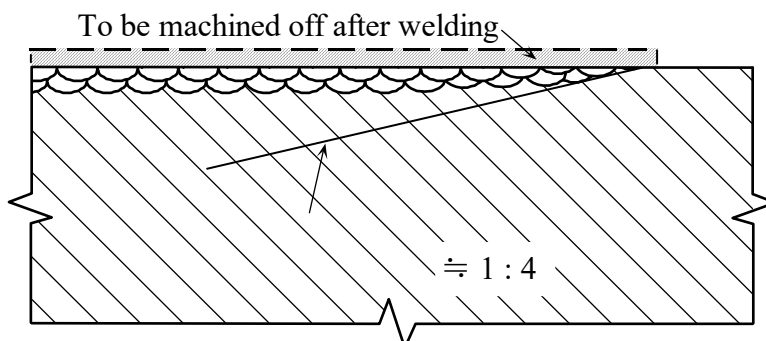

- Post weld heat treatment if required in special cases (never for stainless steel cladding on ordinary steel)
- Final machining, at least two layers of welding material have to remain on the rudder stock (See the above sketch)
- Non-destructive fracture examination

**Figure 3 Rudder stock repair by welding**

**No.**  
**84**  
(cont)**3.2 Plate Structure**

**3.2.1** Fatigue fractures in welding seams (butt welds) caused by welding failures (lack of fusion) can be gouged out and rewelded with proper root penetration.

**3.2.2** In the case of fractures probably caused by (resonant) vibration, vibration analysis of the rudder plating has to be performed, and design modifications have to be carried out in order to change the natural frequency of the plate field.

**3.2.3** Short fatigue fractures starting in the lower and/or upper corners of the pintle recess of semi-spade rudders that do not propagate into vertical or horizontal stiffening structures may be repaired by gouging out and welding. The procedure according to **Example 4** should be preferred.

In the case of longer fatigue fractures starting in the lower and/or upper corners of the pintle recess of semi-spade rudders that propagate over a longer distance into the plating, a thorough check of the internal structures has to be carried out. The fractured parts of the plating and of the internal structures, if necessary, have to be replaced by insert plates. A proper welding connection between the insert plate and the internal stiffening structure is very important (See **Examples 5** and **6**).

The area of the pintle recess corners has to be ground smooth after the repair. In many cases a modification of the radius, an increased thickness of plating and an enhanced steel quality may be necessary.

**3.2.4** For the fractures at the connection between plating and cast pieces an adequate preheating is necessary. The preheating temperature is to be determined taking into account the following parameters:

- a) chemical composition (carbon equivalent  $C_{eq}$ )
- b) thickness of the structure
- c) hydrogen content in the welding consumables
- d) heat input

**3.2.5** As a guide, the preheating temperature can be obtained from **Diagram 1** using the plate thickness and carbon equivalent of the thicker structure.

**3.2.6** All welding repairs are to be carried out using qualified/approved welding procedures.

**No.  
84**  
(cont)

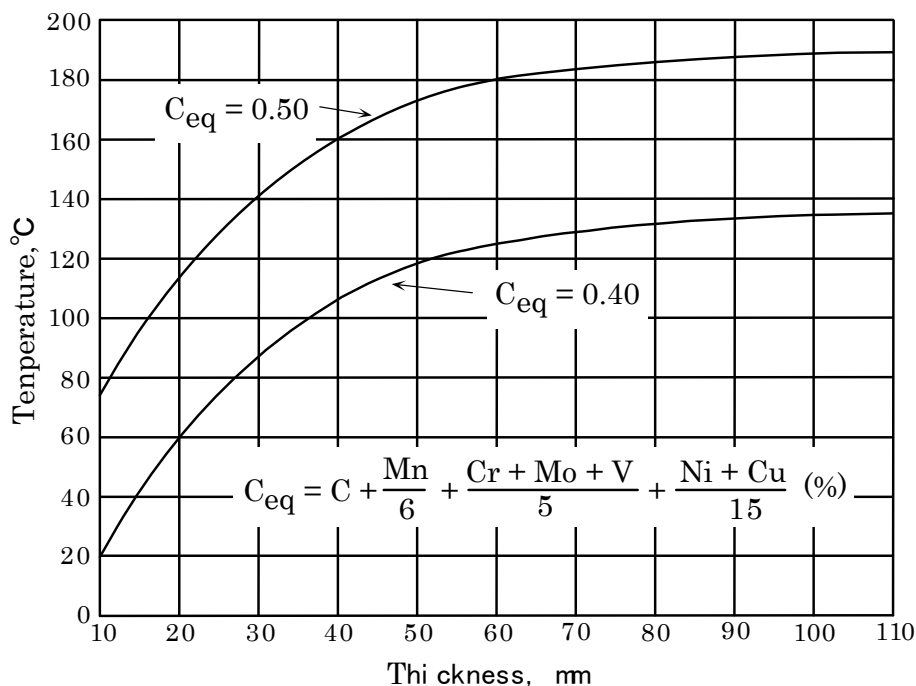

**Diagram 1 Preheating temperature**

### 3.3 Abrasion of bush and sleeve

The abrasion (wear down) rate depends on the features of the ship such as frequency of manoeuvring. However, if excessive clearance is found within a short period, e.g. 5 years, alignment of the rudder arrangement and the matching of the materials for sleeve and bush should be examined together with the replacement of the bush.

### 3.4 Assembling of rudders

During the assembling of the rudder after repair particular attention is to be paid to the alignment of the bearings concerned. For vertical cone couplings the contact surface between rudder stock/pintle and cast piece is to be re-checked after the repair.

After mounting of all parts of the rudder, rudder stocks nuts with a vertical cone coupling and nuts of pintles are to be effectively secured. In the case of horizontal couplings, bolts and their nuts are to be secured either against each other or both against the coupling plates.

### 3.5 Propeller boss and stern tube

Repair examples for the propeller boss and stern tube are shown in Examples 7 and 8. Regarding the welding reference is made to 3.1.4, 3.2.4 and 3.2.5.

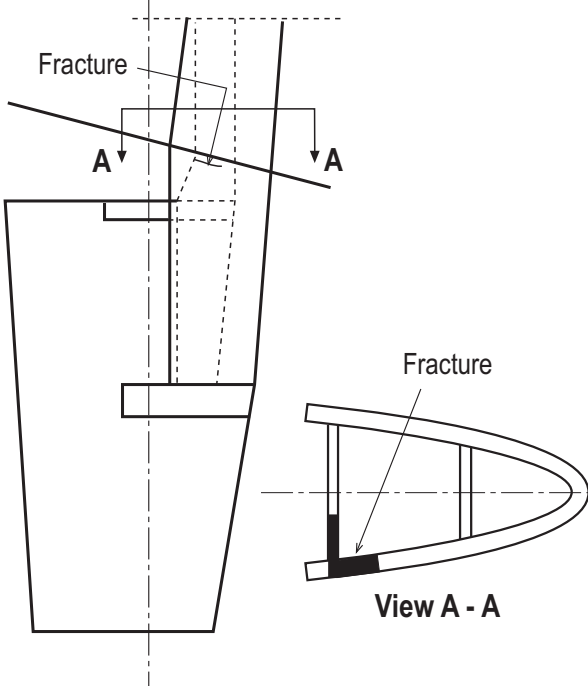
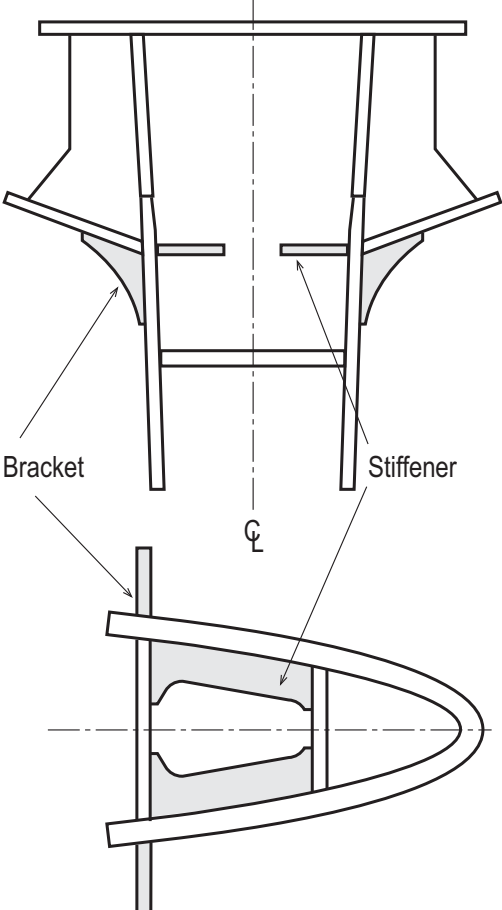

**No. 84**  
(cont)

<b>CONTAINER SHIPS</b>		<b>Guidelines for Surveys, Assessment and Repair of Hull Structure</b>	
<b>Part 2</b>	<b>Fore and aft end regions</b>	<b>Example No. 1</b>	
<b>Area 3</b>	<b>Stern frame, rudder arrangement and propeller shaft support</b>		
<b>Detail of damage</b>	Fractures in rudder horn along bottom shell plating		
<b>Sketch of damage</b>		<b>Sketch of repair</b>	
			
<b>Notes on possible cause of damage</b>		<b>Notes on repairs</b>	
<ol style="list-style-type: none"> <li>Insufficient strength due to poor design.</li> </ol>		<ol style="list-style-type: none"> <li>Fractured plating to be veed-out and rewelded.</li> <li>Fractured plating to be cropped and renewed if considered necessary.</li> <li>Reinforcement should be considered if considered necessary.</li> </ol>	

No. 84  
(cont)

<b>CONTAINER SHIPS</b>		<b>Guidelines for Surveys, Assessment and Repair of Hull Structure</b>	
<b>Part 2</b>	<b>Fore and aft end regions</b>	<b>Example No. 2</b>	
<b>Area 3</b>	<b>Stern frame, rudder arrangement and propeller shaft support</b>	<b>2</b>	
<b>Detail of damage</b>		Fractures in rudder stock	
<b>Sketch of damage</b>		<b>Sketch of repair</b>	
<p>Fracture (see below)</p> <p>View A - A</p>		<p><math>R \geq 100 \text{ mm}</math></p> <p><math>D</math></p> <p><math>\frac{a}{b} = \frac{1}{3} \sim \frac{1}{5}</math></p> <p><math>R \geq 45 \text{ mm}</math></p> <p><math>b</math></p> <p><math>&lt; 8 \text{ mm}</math></p> <p><math>a</math></p> <p><math>30^\circ</math></p> <p><math>2 \text{ mm}</math></p> <p><math>R=8 \text{ mm}</math></p> <p><math>R=8 \text{ mm}</math></p> <p><math>30^\circ</math></p>	
<b>Notes on possible cause of damage</b>		<b>Notes on repairs</b>	
<p>1. Inadequate design for stress concentration in rudder stock.</p>		<p>1. Modification of detail design of rudder stock to reduce the stress concentration.</p>	

**No. 84**  
(cont)

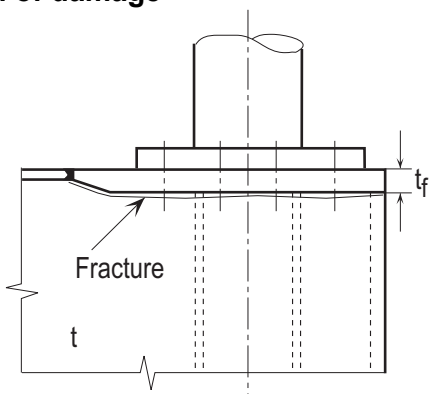
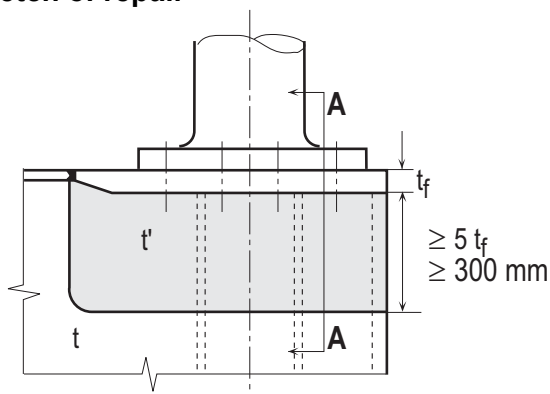
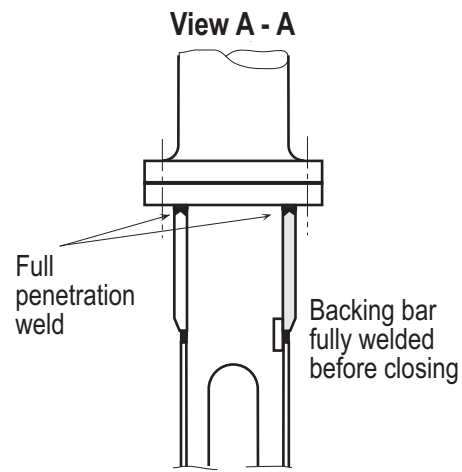
<b>CONTAINER SHIPS</b>		<b>Guidelines for Surveys, Assessment and Repair of Hull Structure</b>	
<b>Part 2</b>	<b>Fore and aft end regions</b>	<b>Example No. 3</b>	
<b>Area 3</b>	<b>Stern frame, rudder arrangement and propeller shaft support</b>		
<b>Detail of damage</b>		Fractures in connection of palm plate to rudder blade	
<b>Sketch of damage</b>		<b>Sketch of repair</b>	
		 <p style="text-align: right;"><math>\geq 5 t_f</math> <math>\geq 300 \text{ mm}</math></p> <p style="text-align: center;"><b>View A - A</b></p>  <p>Full penetration weld</p> <p>Backing bar fully welded before closing</p> <p><math>t</math> = plate thickness [mm]  <math>t_f</math> = actual flange thickness [mm]  <math>t = \frac{t_f}{3} + 5</math> [mm], where <math>t_f \leq 50</math> mm  <math>t = \sqrt[3]{t_f}</math> [mm], where <math>t_f \leq 50</math> mm</p>	
<b>Notes on possible cause of damage</b>		<b>Notes on repairs</b>	
<p>1. Inadequate connection between horizontal coupling plate and rudder blade plating (insufficient plating thickness and/or insufficient fillet weld).</p>		<p>1. Modification of detail design of the connection by increasing the plate thickness and full penetration welding.</p>	

No.  
84

(cont)

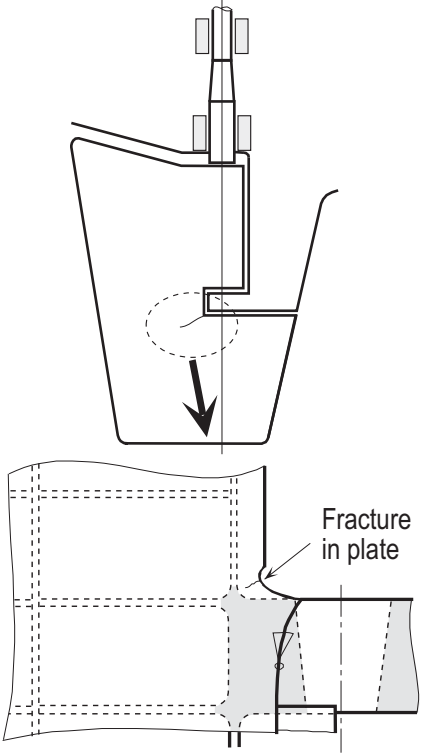
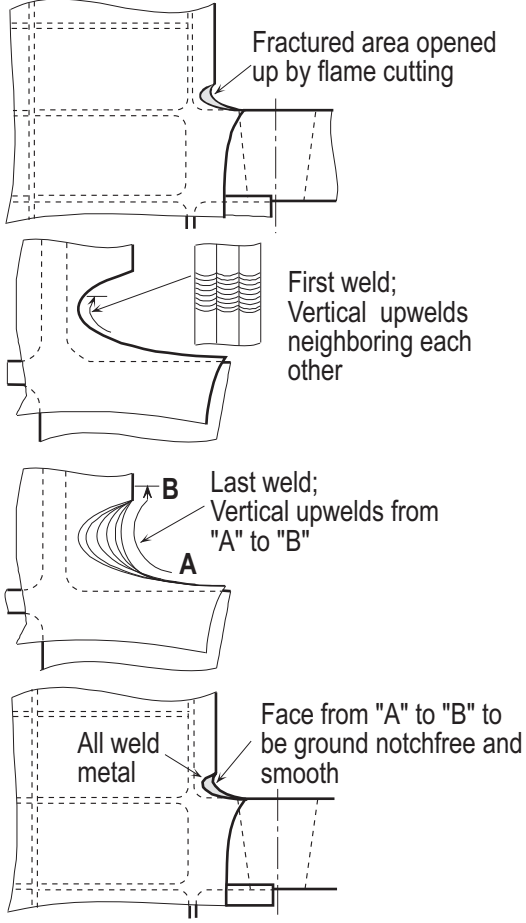
CONTAINER SHIPS		Guidelines for Surveys, Assessment and Repair of Hull Structure	
Part 2	Fore and aft end regions	Example No. 4	
Area 3	Stern frame, rudder arrangement and propeller shaft support		
Detail of damage	Fractures in rudder plating of semi-spade rudder (short fracture with end located forward of the vertical web)		
Sketch of damage		Sketch of repair	
 <p>Fracture in plate</p>		 <p>Fractured area opened up by flame cutting</p> <p>First weld; Vertical upwelds neighboring each other</p> <p>Last weld; Vertical upwelds from "A" to "B"</p> <p>All weld metal</p> <p>Face from "A" to "B" to be ground notchfree and smooth</p>	
Notes on possible cause of damage		Notes on repairs	
<p>1. Stress concentration due to inadequate local design and/or fabrication notches in way of the butt weld between cast piece and plating.</p>		<p>1. Grooving-out and welding of the fracture is not always adequate (metallurgical notch in way of a high stressed area).</p> <p>2. In the proposed repair procedure the metallurgical notches are shifted into a zone exposed to lower stresses.</p> <p>3. After welding a modification of the radius according to the proposal in <b>Example 5</b> is to be carried out.</p> <p>4. In case of very small crack it can be ground off by increasing the radius.</p>	

No.  
84  
(cont)

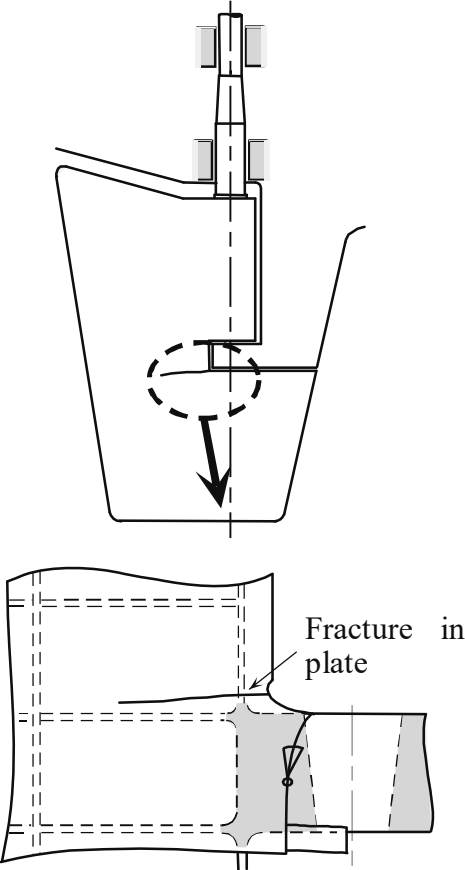
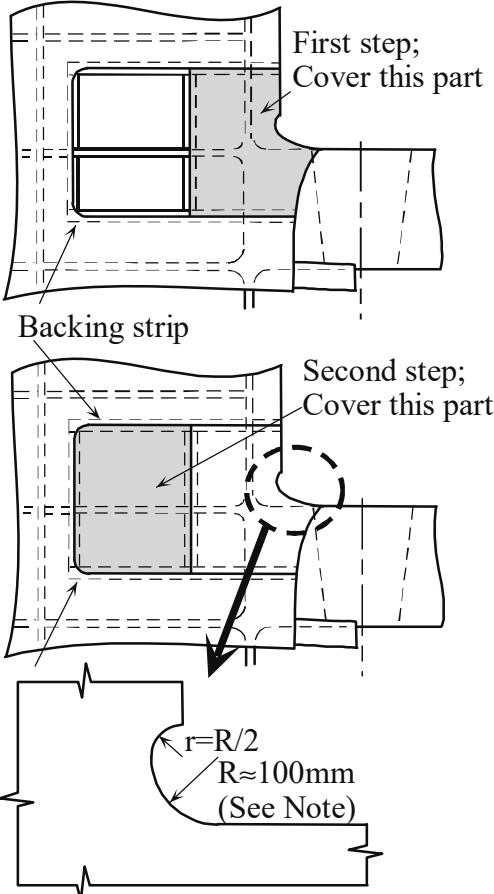
CONTAINER SHIPS		Guidelines for Surveys, Assessment and Repair of Hull Structure	
Part 2	Fore and aft end regions	Example No.	
Area 3	Stern frame, rudder arrangement and propeller shaft support	5	
<b>Detail of damage</b>		Fractures in rudder plating of semi-spade rudder extending beyond the vertical web	
<b>Sketch of damage</b>		<b>Sketch of repair</b>	
 <p>Fracture in plate</p>		 <p>First step; Cover this part</p> <p>Backing strip</p> <p>Second step; Cover this part</p> <p><math>r=R/2</math> <math>R\approx 100\text{mm}</math> (See Note)</p> <p>Note: R should be considered according to local detail</p>	
<b>Notes on possible cause of damage</b>		<b>Notes on repairs</b>	
<ol style="list-style-type: none"> <li>1. Stress concentration due to inadequate local design and/or fabrication notches in way of the butt weld between cast piece and plating.</li> </ol>		<ol style="list-style-type: none"> <li>1. Fractured plating is to be cut-out.</li> <li>2. Internal structures are to be checked.</li> <li>3. Cut-out is to be closed by an insert plating according to the sketch (welding only from one side is demonstrated).</li> <li>4. Modification of the radius.</li> <li>5. In case of a new cast piece, connection with the plating is to be shifted outside the high stress area.</li> </ol>	

No.  
84  
(cont)

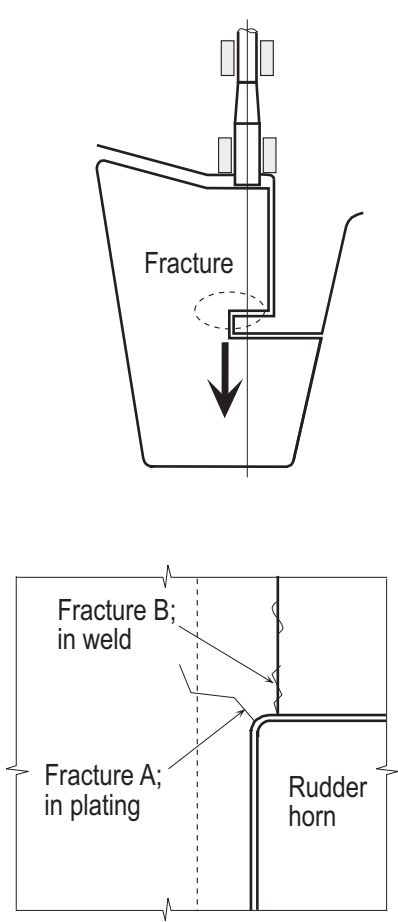
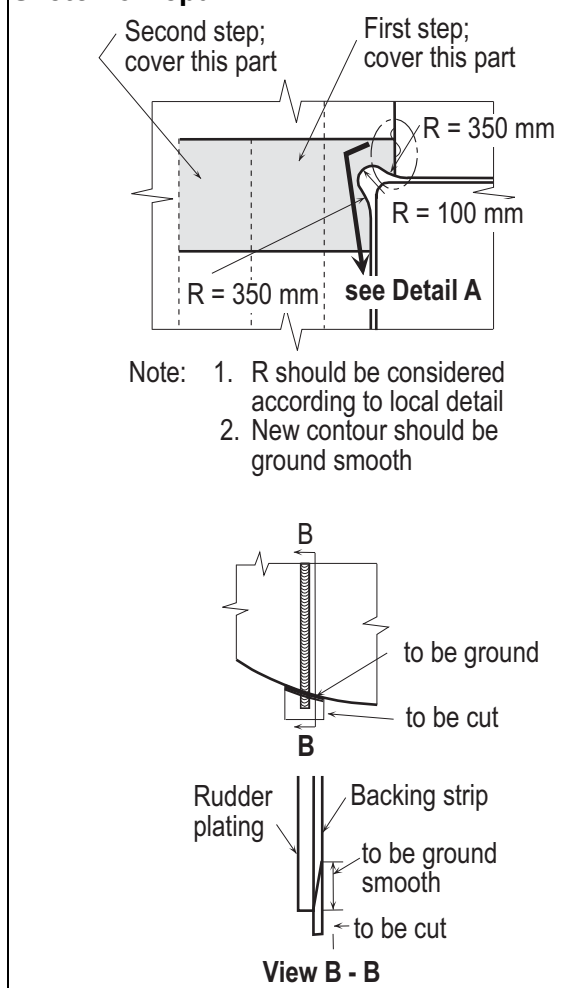
CONTAINER SHIP Guidelines for Surveys, Assessment and Repair of Hull Structure		
Part 2	Fore and aft end regions	Example No.
Area 3	Stern frame, rudder arrangement and propeller shaft support	6
Detail of damage	Fractures in rudder plating of semi-spade rudder in way of pintle cutout	
<p><b>Sketch of damage</b></p>  <p>The sketch shows a semi-spade rudder with a fracture in the plating. A detail view shows 'Fracture B; in weld' and 'Fracture A; in plating' near the 'Rudder horn'.</p>	<p><b>Sketch of repair</b></p>  <p>The repair sketch shows two steps: 'First step; cover this part' and 'Second step; cover this part'. It includes radii <math>R = 350\text{ mm}</math> and <math>R = 100\text{ mm}</math>. A note states: 'Note: 1. R should be considered according to local detail 2. New contour should be ground smooth'. A 'View B - B' shows 'Rudder plating', 'Backing strip', and areas 'to be ground' and 'to be cut'.</p>	
<p><b>Notes on possible cause of damage</b></p> <ol style="list-style-type: none"> <li>1. Inadequate design for stress concentration in way of pintle bearing (<b>Fracture A</b>).</li> <li>2. Imperfection in welding seam (<b>Fracture B</b>).</li> </ol>	<p><b>Notes on repairs</b></p> <ol style="list-style-type: none"> <li>1. Fractured part to be cropped off.</li> <li>2. Repair by two insert plates of modified, stress releasing contour. For the vertical seam no backing strip is used 100mm off contour, welding from both sides, to be ground after welding.</li> <li>3. Variant (See <b>Detail A</b>): Repair as mentioned under 2 with the use of backing strip for the complete vertical seam. After welding backing strip partly removed by grinding.</li> </ol>	

No.  
84  
(cont)

CONTAINER SHIP		Guidelines for Surveys, Assessment and Repair of Hull Structure	
Part 2	Fore and aft end regions		Example No.
Area 3	Stern frame, rudder arrangement and propeller shaft support		7
Detail of damage		Fractures in side shell plating at the connection with propeller boss	
<p><b>Sketch of damage</b></p> <p>Fracture</p> <p>Propeller boss</p> <p>Fracture started at HAZ of welding</p> <p>View A - A</p>		<p><b>Sketch of repair</b></p> <p>Additional stiffener</p> <p>Collar plate</p> <p>View B - B</p>	
<p><b>Notes on possible cause of damage</b></p> <ol style="list-style-type: none"> <li>1. Fatigue fracture due to vibration.</li> </ol>		<p><b>Notes on repairs</b></p> <ol style="list-style-type: none"> <li>1. Fractured side shell plating is to be cropped and part renewed.</li> <li>2. Additional stiffeners are to be provided.</li> <li>3. Collar plate is to be provided.</li> </ol>	

No.  
84  
(cont)

<b>CONTAINER SHIP</b>		<b>Guidelines for Surveys, Assessment and Repair of Hull Structure</b>	
<b>Part 2</b>	<b>Fore and aft end regions</b>		<b>Example No.</b>
<b>Area 3</b>	<b>Stern frame, rudder arrangement and propeller shaft support</b>		<b>8</b>
<b>Detail of damage</b>		Fractures in stern tube at the connection with stern frame	
<b>Sketch of damage</b>		<b>Sketch of repair</b>	
<b>Notes on possible cause of damage</b>		<b>Notes on repairs</b>	
<ol style="list-style-type: none"> <li>1. Fatigue fracture due to vibration.</li> </ol>		<ol style="list-style-type: none"> <li>1. Fractured tube is to be veed-out and welded from both sides.</li> <li>2. Brackets are to be replaced by modified brackets with soft transition.</li> </ol>	



**No. Part 3 Machinery and accommodation spaces**

**84**

(cont)

Contents

Area 1 – Engine room structures

Area 2 – Accommodation structures

---

**No. Area 1 Engine room structures****84**

(cont)

**Contents**

- 1 General**
- 2 What to look for – Engine room inspection**
  - 2.1 Material wastage**
  - 2.2 Fractures**
- 3 What to look for – Tank inspection**
  - 3.1 Material wastage**
  - 3.2 Fractures**
- 4 General comments on repair**
  - 4.1 Material wastage**
  - 4.2 Fractures**

**Examples of structural detail failures and repairs – Area 1****Example No. Title**

1	Fractures in brackets at main engine foundation
2	Corrosion in bottom plating under sounding pipe in way of bilge storage tank in the engine room
3	Corrosion in bottom plating under inlet/suction pipe in way of bilge storage tank in the engine room

**No.  
84**

(cont)

**1 General**

The engine room structure is categorized as follows:

- Boundary structure which consists of upper deck, bulkhead, inner bottom plating, funnel, etc.
- Deep tank structure
- Double bottom tank structure

The boundary structure can generally be inspected routinely and therefore any damages found can usually be easily rectified. Deep tank and double bottom structures, owing to access difficulties, generally cannot be inspected routinely. Damage of these structures is usually only found during dry docking or when a leakage is in evidence.

**2 What to look for – Engine room inspection****2.1 Material wastage**

**2.1.1** Tank top plating, shell plating and bulkhead plating adjacent to the tank top plating may suffer severe corrosion caused by leakage or lack of maintenance of sea water lines.

**2.1.2** The bilge well should be cleaned and inspected carefully for heavy pitting corrosion caused by sea water leakage at gland packing or maintenance operation of machinery.

**2.1.3** Parts of the funnel forming the boundary structure often suffer severe corrosion which may impair weathertightness and fire fighting in the engine room.

**2.2 Deformations**

**2.2.1** Contact with quay sides and other objects can result in large deformations and fractures of the internal structure. This may affect the watertight integrity of the tank boundaries and collision bulkhead. An examination of the damaged area should be carried out to determine the extent of the damage.

**3 What to look for – Tank inspection****3.1 Material wastage**

**3.1.1** The environment in bilge tanks, where a mixture of oily residue and seawater is accumulated, is more corrosive when compared to other double bottom tanks. Severe corrosion may result in holes in the bottom plating, especially under sounding pipes. Pitting corrosion caused by seawater entering via an air pipe is occasionally found in cofferdam spaces.

**3.2 Fractures**

**3.2.1** In general, deep tanks for fresh water or fuel oil are located in the engine room. The structure in these tanks often sustains fractures due to vibration. Fracture of double bottom structure in the engine room is seldom found due to its high structural rigidity.

**No.  
84**

(cont)

**4 General comments on repair****4.1 Material wastage**

**4.1.1** Where part of the structure has deteriorated to the permissible minimum thickness, then the affected area is to be cropped and renewed.

Repair work in a double bottom will require careful planning in terms of accessibility and gas freeing is required for repair work in fuel oil tanks.

**4.2 Deformations**

**4.2.1** When buckling of the tank top plating has occurred, appropriate reinforcement is necessary in addition to cropping and renewal, regardless of the corrosion condition of the plating.

**4.3 Fractures**

**4.3.1** For fatigue fractures caused by vibration, in addition to the normal repair of the fractures, consideration should be given to modification of the natural frequency of the structure to avoid resonance. This may be achieved by providing additional structural reinforcement, however, in many cases, a number of tentative tests may be required to reach the desired solution.

No.  
84

(cont)

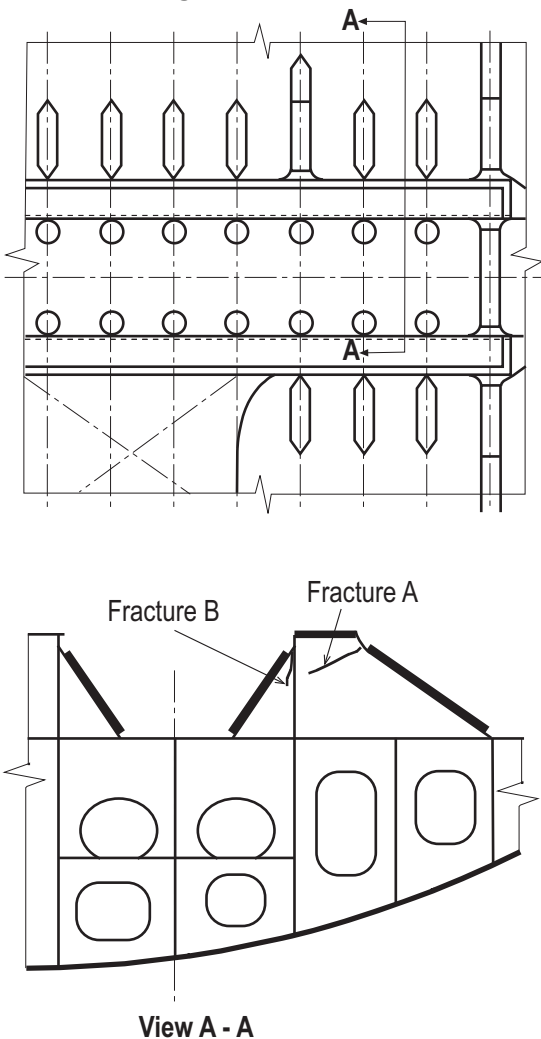
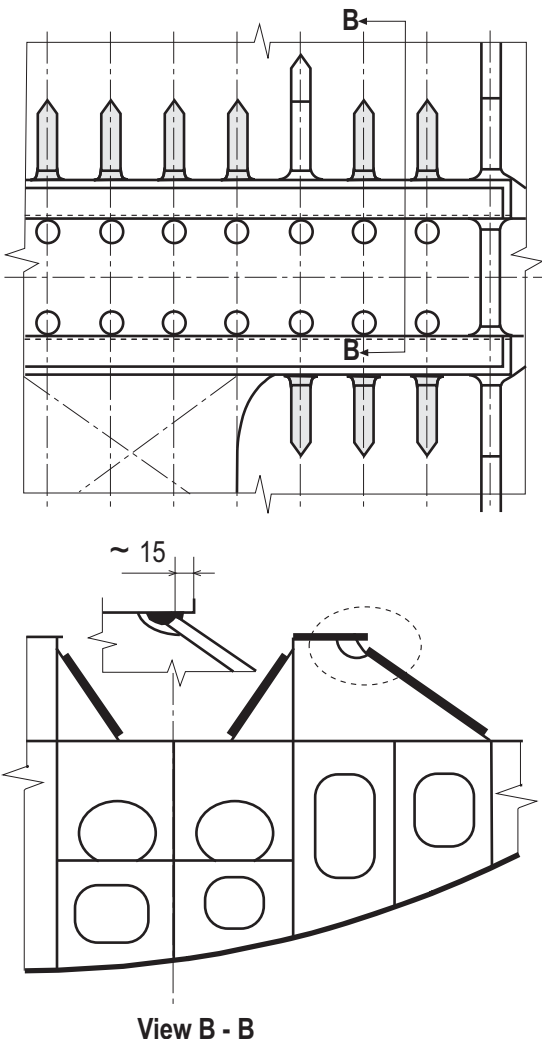
CONTAINER SHIPS		Guidelines for Surveys, Assessment and Repair of Hull Structure	
Part 3	Machinery and accommodation spaces	Example No. 1	
Area 1	Engine room structure		
Detail of damage		Fractures in brackets at main engine foundation	
Sketch of damage		Sketch of repair	
 <p>View A - A</p>		 <p>View B - B</p>	
Notes on possible cause of damage		Notes on repairs	
<ol style="list-style-type: none"> <li>1. Vibration of main engine.</li> <li>2. Insufficient strength of brackets at main engine foundation.</li> <li>3. Insufficient pre-load bolts.</li> </ol>		<ol style="list-style-type: none"> <li>1. Fractures are to be veed-out and rewelded.</li> <li>2. New modified brackets at main engine foundation.</li> <li>3. Or insert pieces and additional flanges to increase section modulus of the brackets.</li> </ol>	

**No. 84**  
(cont)

<b>CONTAINER SHIPS</b>		<b>Guidelines for Surveys, Assessment and Repair of Hull Structure</b>	
<b>Part 3</b>	<b>Machinery and accommodation spaces</b>	<b>Example No. 2</b>	
<b>Area 1</b>	<b>Engine room structure</b>		
<b>Detail of damage</b>	Corrosion in bottom plating under sounding pipe in way of bilge storage tank in engine room		
<b>Sketch of damage</b>		<b>Sketch of repair</b>	
<p>Shell expansion in way of bilge tank</p> <p>Inner bottom plate</p> <p>Bilge tank</p> <p>Keel plate</p> <p>Sounding pipe</p> <p>Striking pipe</p> <p>Hole</p>		<p>Renewal of striking plate</p> <p>Repair by welding</p> <p>Renewal of striking plate</p> <p>Renewal of bottom plate</p> <p>Renewal of striking plate</p> <p>Renewal of bottom plate by spigot welding</p>	
<b>Notes on possible cause of damage</b>		<b>Notes on repairs</b>	
<p>1. Heavy corrosion of bottom plating under sounding pipe.</p>		<p>1. Corroded striking plating should be renewed.</p> <p>2. Bottom plate should be repaired depending on the condition of corrosion.</p> <p>(Note)</p> <p>Repair by spigot welding can be applied to the structure only when the stress level is considerably low. Generally this procedure cannot be applied to the repair of bottom plating of ballast tanks in cargo hold region.</p>	

No.  
84

(cont)

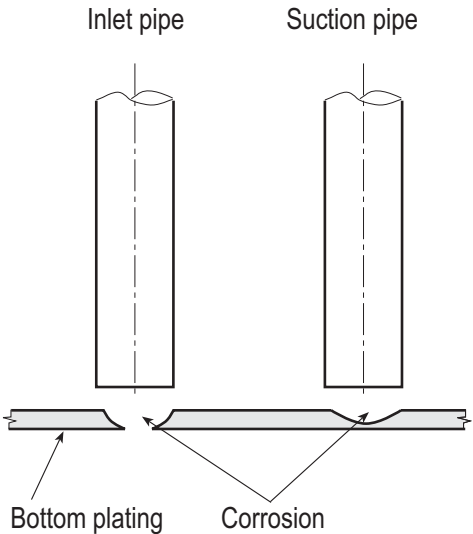
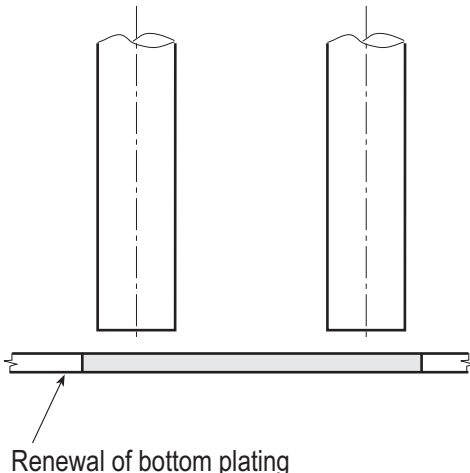
CONTAINER SHIPS		Guidelines for Surveys, Assessment and Repair of Hull Structure	
Part 3	Machinery and accommodation spaces		Example No.
Area 1	Engine room structure		3
<b>Detail of damage</b>		Corrosion in bottom plating under inlet/suction/pipe in way of bilge storage tank in engine room	
<b>Sketch of damage</b>		<b>Sketch of repair</b>	
			
<b>Notes on possible cause of damage</b>		<b>Notes on repairs</b>	
<p>1. Heavy corrosion of bottom plating under the inlet/suction pipe.</p>		<p>1. Corroded bottom plating is to be cropped and part renewed. Thicker plate is preferable.</p> <p>2. Replacement of pipe end by enlarged conical opening (similar to suction head in ballast tank) is preferable.</p>	

---

**No. Area 2 Accommodation structure****84**

(cont)

**Contents****1 General****Figures and/or Photographs – Area 2****No.****Title**

---

Photograph 1	Corroded accommodation house side structure
--------------	---

---



**No. 1 General**

**84**  
(cont) Corrosion is the main concern in accommodation structures and deck houses of ageing ships. Owing to the lesser thickness of the structure plating, corrosion can propagate through the thickness of the plating resulting in holes in the structure.

Severe corrosion may be found in exposed deck plating and the deck house side structure adjacent to the deck plating where water is liable to accumulate (See **Photograph 1**). Corrosion may also be found in accommodation bulkheads around the cutout for fittings, such as doors, side scuttles, ventilators, etc., where proper maintenance of the area is relatively difficult. Deterioration of the bulkheads including fittings may impair the integrity of weathertightness.

Fatigue fractures caused by vibration may be found in the structure itself and in various stays of the structures, mast, antenna etc. For such fractures, consideration should be given to modify the natural frequency of the structure by providing additional reinforcement during repair.



**Photograph 1 Corroded accommodation house side structure**

End of  
Document