

**REPUBLIC OF
THE MARSHALL ISLANDS**

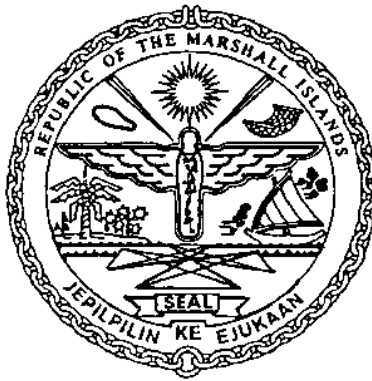

**YACHT CODE
2021**

MARITIME ADMINISTRATOR

May/2021

MI-103 (2021)

NOTICE

The Republic of the Marshall Islands Yacht Code ([MI-103](#)) is designed to be read and used as an electronic document. It includes hyperlinks to referenced publications and internal sub-sections. The link to the updated version of this publication, and any supplements thereto, may be found at www.register-iri.com.

Any complimentary printing of this publication will not be automatically supplemented, and therefore, may be **out of date**.

Requests to be included in the email notification updating service, MI-300 Updates, may be sent to publications@register-iri.com.

REPUBLIC OF THE MARSHALL ISLANDS YACHT CODE

TABLE OF CONTENTS

CHAPTER I: INTRODUCTION, GENERAL APPLICATION, AND DEFINITIONS.....	1
1.0 INTRODUCTION.....	2
2.0 GENERAL.....	3
2.1 Application.....	3
2.1.1 Effective Date	3
2.1.2 Commercial Yachts.....	3
2.1.3 Passenger Yachts (PAXYs).....	3
2.1.4 Private Yachts Limited Charter (PYLCs)	3
2.1.5 Yachts Engaged in Trade (YETs)	3
2.2 Responsibility	4
2.3 Equivalent Standards	4
2.4 Operational Limitations	4
2.5 Coastal State Requirements	5
2.6 Name and Port of Registry.....	6
2.7 Administrator Notices, Advisories, and Circulars	6
2.8 Yacht Contact Email Addresses.....	6
2.9 Yachts Taking Part in Races	7
2.10 Carriage of Supernumeraries	7
3.0 DEFINITIONS	7
CHAPTER II: COMMERCIAL YACHTS.....	19
1.0 STATUTORY AND NATIONAL REQUIREMENTS.....	20
1.1 Convention on the International Regulations for Preventing Collisions at Sea, 1972 (COLREGS '72)	20
1.2 International Convention on Tonnage Measurement of Ships, 1969 (ITC).....	20
1.3 International Convention for the Prevention of Pollution from Ships (MARPOL).....	20
1.3.1 MARPOL Annex I.....	20
1.3.2 MARPOL Annex IV	21
1.3.3 MARPOL Annex V	21
1.3.4 MARPOL Annex VI.....	21
1.4 Anti-Fouling.....	22
1.5 International Convention for the Control and Management of Ships' Ballast Water and Sediments, 2004 (BWM Convention).....	22
1.6 Nairobi International Convention on the Removal of Wrecks, 2007 (WRLC)	22
1.7 International Convention on Civil Liability for Bunker Oil Pollution Damage (CLBC) .	22
1.8 Standards of Training, Certification and Watchkeeping for Seafarers, 1978 (STCW).....	23
1.9 International Convention on Load Lines, 1966 (ILLC).....	23

1.10	International Convention for the Safety of Life at Sea (SOLAS).....	23
1.10.1	SOLAS Chapters II-1 and II-2: Safety Construction.....	23
1.10.2	Classification and Certification	23
1.10.3	SOLAS Chapter III: Safety Equipment	23
1.10.4	SOLAS Chapter IV: Radio Communications.....	24
1.10.5	SOLAS XI-1/3: IMO Number.....	24
1.11	International Safety Management (ISM) Code.....	24
1.12	International Ship and Port Facility Security (ISPS) Code.....	25
1.13	Maritime Labour Convention, 2006 (MLC, 2006)	25
1.14	International Code of Safety for Ships using Gases or other Low-flashpoint Fuels (IGF) Code.....	25
1.15	Inventory of Hazardous Materials (IHM).....	25
2.0	CONVENTION SURVEYS	25
2.1	Survey Standards	25
2.2	Survey Requests.....	26
2.3	Statements of International Convention Voluntary Compliance	26
3.0	MAINTAINING COMPLIANCE WITH THIS CODE.....	26
3.1	General.....	26
3.2	Statutory Compliance and RMI Certification.....	26
3.3	Commercial Yachts Constructed in Accordance with the Code.....	27
4.0	CONSTRUCTION.....	27
4.1	General Requirements.....	27
4.2	Structural Strength	27
4.3	Watertight Bulkheads	28
4.4	Enclosed Compartments Within the Hull and Below the Freeboard Deck Provided with Access through Openings in the Hull	28
4.5	Underwater Observation Spaces	29
5.0	CONDITIONS OF ASSIGNMENT	30
5.1	General.....	30
5.2	Hatchways and Skylight Hatches.....	30
5.2.1	General Requirements.....	30
5.2.2	Hatchways Open at Sea.....	31
5.3	Doorways and Companionways Located Above the Weather Deck	31
5.4	Skylights	32
5.5	Glazed Openings.....	33
5.6	Ventilators and Exhausts	34
5.7	Air Pipes	35
5.8	Scuppers, Sea Inlets, and Discharges.....	35
5.9	Materials for Valves and Associated Piping.....	35

5.10	Underwater Lights	36
5.11	Water Freeing Arrangements.....	36
5.12	Bulwarks and Guard Rails	37
5.13	General Equivalence	37
6.0	FREEBOARD	38
6.1	General.....	38
6.2	Freeboard Mark and Loading.....	38
6.3	Draft and Load Line Marks.....	39
	6.3.1 Draft Marks.....	39
	6.3.2 Load Line Marks.....	39
6.4	Docking Plan.....	39
7.0	STABILITY – INTACT AND DAMAGED.....	40
7.1	General.....	40
7.2	Intact Stability.....	40
	7.2.1 All Motor Yachts	40
	7.2.2 Equivalent Stability Standards.....	41
	7.2.3 High Speed Yachts.....	41
	7.2.4 Sailing Yachts	41
7.3	Damage Stability.....	41
7.4	Elements of Stability.....	43
7.5	Stability Documents.....	43
7.6	Major Refit or Alterations.....	44
8.0	SAILING YACHT RIGGING	45
8.1	General.....	45
8.2	Masts and Spars	45
8.3	Running and Standing Rigging.....	45
8.4	Sails.....	46
9.0	ACCOMMODATIONS.....	46
9.1	General.....	46
9.2	New Yachts.....	46
9.3	Existing Yachts	46
9.4	Headroom and Ceiling Heights.....	47
9.5	Hand Holds and Grab Rails	47
9.6	Access/Escape Arrangements	48
9.7	Lighting.....	48
9.8	Heating and Insulation	48
9.9	Noise and Vibration.....	48
9.10	Food Preparation and Storage Facilities	48
9.11	Water Services	49

9.12	Sleeping Accommodation.....	50
9.13	Stowage Facilities for Personal Effects	52
9.14	Sanitary Facilities	52
9.15	Recreational Facilities.....	53
9.16	Laundry Facilities	53
9.17	Office Space.....	53
9.18	Diversity.....	54
9.19	Onboard Inspections	54
9.20	Mosquito Protection.....	54
9.21	Securing of Heavy Equipment.....	54
9.22	Hospital Facilities	55
9.23	Elevators (Lifts), Escalators, and Other Accommodation Lifting Devices	55
10.0	FIRE SAFETY AND PREVENTION.....	56
10.1	Stowage of Gasoline, Aviation Fuel, and Other Highly Flammable Liquids	56
10.1.1	Portable Containers Including Portable Tanks	56
10.1.2	Permanent Tanks	57
10.1.3	Spaces Designed to Contain Vehicles	58
10.2	Saunas	60
10.3	Steam Room (Thermal Suite)	61
10.4	Fire Control Plans	61
11.0	STRUCTURAL FIRE PROTECTION FOR YACHTS OF LESS THAN 500 GT	62
11.1	Boundaries	62
11.2	Arrangement of Fuel Oil Tanks and Piping.....	66
11.3	Ventilation	67
11.4	Means of Escape	68
11.5	Materials	69
11.6	Open Flame Gas Appliances and Recreational Fire Appliances (RFAs)	70
11.7	Deep Fat Cooking Equipment.....	70
11.8	Paints, Varnishes, and Other Finishes.....	70
11.9	Fire Detection and Fire Alarm Systems.....	70
12.0	STRUCTURAL FIRE PROTECTION FOR YACHTS OF 500 GT AND ABOVE.....	71
12.1	Boundaries	71
12.2	Fire Integrity	72
12.3	Fire Risk Categories.....	74
12.4	Openings in “A” Class Divisions.....	75
12.5	Openings in “B” Class Divisions.....	77
12.6	Windows and Side Scuttles.....	78
12.7	Main Vertical Zones and Horizontal Zones.....	78
12.8	Bulkheads Within a Main Vertical Zone	79

12.9	Structural Integrity	79
12.10	Details of Construction	81
12.11	Ventilation Systems	82
12.12	Protection of Stairways and Elevators (Lifts) in Accommodation and Service Spaces....	83
12.13	Means of Escape	83
	12.13.1 Accommodation and Service Spaces.....	83
	12.13.2 Machinery Spaces.....	85
12.14	Materials	86
12.15	Deep Fat Cooking Equipment.....	87
12.16	Suppression of Fire	87
12.17	Fire Detection and Alarms.....	88
12.18	Public Address Systems.....	89
12.19	Lubricating Oil Arrangements	89
12.20	Arrangements for Other Flammable Oils	89
12.21	Prohibition of Carriage of Flammable Oils in Forepeak Tanks.....	89
12.22	Arrangements for Gaseous Fuel for Domestic Purposes	89
12.23	Space Heaters.....	89
12.24	Paints, Varnishes, and Other Finishes.....	89
12.25	Open Flame Gas Appliances and RFAs.....	90
12.26	Arrangement of Fuel Oil Tanks and Piping.....	90
12.27	Emergency Escape Breathing Devices (EEBDs).....	90
13.0	MACHINERY FOR YACHTS OF LESS THAN 500 GT	90
13.1	General Requirements.....	90
13.2	Installation	91
13.3	Steering Gear	92
	13.3.1 Steering Systems.....	92
	13.3.2 Emergency Steering.....	92
13.4	Bilge Pumping Arrangements.....	92
	13.4.1 Pumps	92
	13.4.2 Periodically Unmanned Machinery Spaces	93
	13.4.3 Pumping and Piping Arrangements.....	93
13.5	Electrical Installations.....	94
	13.5.1 Installation	94
	13.5.2 Emergency Sources of Power.....	95
	13.5.3 Emergency Lighting	96
	13.5.4 Batteries.....	97
	13.5.5 Battery Systems for (Hybrid) Propulsion	97
14.0	MACHINERY FOR YACHTS 500 GT AND ABOVE	97
14.1	General Requirements.....	97

14.2	Main Steering Gear.....	98
14.3	Bilge Pumping Arrangements.....	98
14.4	Electrical Installation.....	98
14.5	Battery Systems for (Hybrid) Propulsion.....	99
15.0	FIRE-FIGHTING EQUIPMENT - YACHTS OF LESS THAN 500 GT.....	99
15.1	General Requirements.....	99
15.2	Specific Requirements.....	99
15.2.1	Fire Pumps.....	99
15.2.2	Fire Main and Hydrants.....	100
15.2.3	Fire Hoses and Nozzles.....	101
15.2.4	Portable Fire Extinguishers for Use in the Accommodation and Service Spaces.....	102
15.2.5	Fire Extinguishing in Machinery Spaces.....	102
15.2.6	Additional Fire Appliances.....	103
16.0	FIRE-FIGHTING EQUIPMENT - COMMERCIAL YACHTS 500 GT AND ABOVE	103
17.0	LIFE-SAVING APPLIANCES.....	104
17.1	General Requirements.....	104
17.1.1	Life-Saving Appliances.....	104
17.1.2	Launching Appliances.....	106
17.2	Equipment Carriage Requirements.....	107
17.2.1	Lifeboats.....	107
17.2.2	Life Rafts.....	108
17.2.3	Recovery of Persons from the Sea.....	109
17.2.4	Rescue Boats.....	110
17.2.5	Life Buoys.....	112
17.2.6	Lifejackets.....	112
17.2.7	Immersion Suits.....	113
17.2.8	Pyrotechnics.....	113
17.2.9	Line Throwing Appliances.....	113
17.2.10	Emergency Position-Indicating Radio Beacon (EPIRB).....	113
17.2.11	Search and Rescue Transponder (SART).....	114
17.2.12	General Alarm.....	114
17.2.13	Lighting.....	114
17.2.14	Life-Saving Signals and Rescue Poster.....	114
18.0	NAVIGATIONAL LIGHTS, SHAPES, AND SOUND SIGNALS.....	115
18.1	General.....	115
19.0	NAVIGATIONAL AND BRIDGE EQUIPMENT AND BRIDGE VISIBILITY.....	115
19.1	Requirements.....	115
19.2	Navigational Equipment Requirements.....	116

19.2.1	Standard Magnetic Compass	116
19.2.2	Gyro Compass	117
19.2.3	Global Navigation Satellite System (GNSS).....	118
19.2.4	Automatic Identification System (AIS).....	118
19.2.5	Long-Range Identification and Tracking (LRIT) System	118
19.2.6	9 GHz Radar (X-band)	118
19.2.7	3 GHz Radar (S-band).....	118
19.2.8	Nautical Charts and Nautical Publications or ECDIS	119
19.2.9	Speed and Distance Measuring Device	119
19.2.10	Echo Sounder.....	119
19.2.11	Rudder, Propeller, Thrust, Pitch, and Operational Mode Indicators	119
19.2.12	Signaling Lamp.....	119
19.2.13	Searchlight.....	119
19.2.14	Instruments	119
19.2.15	Radar Reflector.....	119
19.3	Bridge Navigational Watch Alarm System (BNWAS).....	120
19.4	Bridge Visibility	120
20.0	RADIO	120
20.1	General.....	120
20.2	Sources of Energy.....	122
20.3	Watches.....	122
20.4	Radio Personnel	122
20.5	Global Maritime Distress and Safety System (GMDSS) Logbooks.....	122
21.0	PUBLICATIONS	122
22.0	DECK EQUIPMENT	123
22.1	Equipment.....	123
22.2	Anchors.....	123
22.3	Sailing Yachts.....	124
22.4	Towing Arrangements	124
23.0	MEDICAL STORES	124
23.1	General.....	124
24.0	YACHT-SHORE TRANSFER	125
24.1	Tenders.....	125
24.2	Pilot Transfer Arrangements.....	125
24.3	Gangways, Accommodation Ladders, and Passerelles.....	125
25.0	HELICOPTER AND LANDING FACILITIES	126
26.0	SUBMERSIBLES	126
26.1	General Requirements.....	126
26.2	Lifting Appliances and Attachments	127

26.3	Operation	127
27.0	SAFE WORKING PRACTICES.....	127
27.1	Safe Work Aloft, Over the Side, at Heights, and on the Bowsprit of Sailing Yachts.....	127
27.2	Man-Riding Cranes.....	129
27.3	Noise and Vibration.....	130
27.4	Training Manual	130
27.5	Instructions for Onboard Maintenance	131
27.6	Safety Management System (SMS).....	131
27.7	Maritime Security	131
28.0	PASSENGERS	131
28.1	Limitations.....	131
29.0	MANNING	132
29.1	Minimum Safe Manning.....	132
29.2	Crew Certification.....	132
CHAPTER III: PASSENGER YACHTS (PAXYS).....		133
1.0	STATUTORY AND NATIONAL REQUIREMENTS.....	134
1.1	Convention on the International Regulations for Preventing Collisions at Sea, 1972 (COLREGS '72)	134
1.2	International Convention on Tonnage Measurement of Ships, 1969 (ITC).....	134
1.3	International Convention for the Prevention of Pollution from Ships (MARPOL).....	134
	1.3.1 MARPOL Annex I.....	135
	1.3.2 MARPOL Annex IV	135
	1.3.3 MARPOL Annex V	135
	1.3.4 MARPOL Annex VI.....	136
1.4	Anti-Fouling.....	136
1.5	International Convention for the Control and Management of Ships' Ballast Water and Sediments, 2004 (BWM Convention).....	137
1.6	Nairobi International Convention on the Removal of Wrecks, 2007 (WRLC)	137
1.7	International Convention on Civil Liability for Bunker Oil Pollution Damage (CLBC).....	137
1.8	Athens Convention Relating to the Carriage of Passengers and Their Luggage by Sea (PAL).....	137
1.9	International Convention on Load Lines, 1966 (ILLC).....	137
1.10	International Convention for the Safety of Life at Sea (SOLAS).....	137
	1.10.1 SOLAS Chapter II-1, II-2, III, and IV: Passenger Ship Safety Certificate... ..	137
	1.10.2 Classification and Certification	138
	1.10.3 SOLAS XI-1/3: IMO Number.....	138
1.11	International Safety Management (ISM) Code.....	138
1.12	International Ship and Port Facility Security (ISPS) Code.....	139
1.13	Maritime Labour Convention, 2006 (MLC, 2006).....	139

1.14	International Code of Safety for Ships using Gases or other Low-flashpoint Fuels (IGF) Code.....	139
1.15	Inventory of Hazardous Materials (IHM).....	139
1.16	Standards of Training, Certification and Watchkeeping for Seafarers, 1978 (STCW)...	139
2.0	CONVENTION SURVEYS	140
2.1	Survey Standards	140
2.2	Survey Requests.....	140
2.3	Statements of International Convention Voluntary Compliance	140
3.0	MAINTAINING COMPLIANCE WITH THE CODE	140
3.1	General.....	140
3.2	Statutory Compliance and RMI Certification	140
3.3	PAXYs Constructed in Accordance with the Code	141
4.0	YACHT-SHORE TRANSFER	141
4.1	Tenders.....	141
5.0	HELICOPTER AND LANDING FACILITIES	142
6.0	SUBMERSIBLES	142
6.1	General Requirements.....	142
6.2	Lifting Appliances and Attachments	142
6.3	Operation	143
7.0	SAFE WORKING PRACTICES.....	143
7.1	Safe Work Aloft, Over the Side, at Heights, and on the Bowsprit of Sailing PAXYs ...	143
7.2	Man-Riding Cranes.....	145
7.3	Noise and Vibration.....	145
7.4	Training Manual	146
7.5	Instructions for Onboard Maintenance	146
7.6	Safety Management System.....	147
7.7	Maritime Security	147
8.0	PASSENGERS	147
8.1	Limitations.....	147
9.0	MANNING	147
9.1	Minimum Safe Manning.....	147
9.2	Crew Certification.....	147
CHAPTER IV: PRIVATE YACHTS LIMITED CHARTER (PYLCS)		148
1.0	STATUTORY AND NATIONAL REQUIREMENTS.....	149
1.1	Convention on the International Regulations for Preventing Collisions at Sea, 1972 (COLREGS '72)	149
1.2	International Convention on Tonnage Measurement of Ships, 1969 (ITC).....	149
1.3	International Convention for the Prevention of Pollution from Ships (MARPOL).....	149

1.3.1	MARPOL Annex I.....	149
1.3.2	MARPOL Annex IV	150
1.3.3	MARPOL Annex V	150
1.3.4	MARPOL Annex VI.....	150
1.4	Anti-Fouling.....	151
1.5	International Convention for the Control and Management of Ships' Ballast Water and Sediments, 2004 (BWM Convention).....	151
1.6	Nairobi International Convention on the Removal of Wrecks, 2007 (WRLC)	151
1.7	Standards of Training, Certification and Watchkeeping for Seafarers, 1978 (STCW)...	151
1.8	International Code of Safety for Ships using Gases or other Low-Flashpoint Fuels (IGF) Code.....	152
2.0	CONVENTION SURVEYS	152
2.1	Survey Standards	152
2.2	Survey Requests.....	152
2.3	Statements of International Convention Voluntary Compliance	152
3.0	MAINTAINING COMPLIANCE WITH THIS CODE	152
3.1	General.....	152
3.2	Statutory Compliance and RMI Certification	153
3.3	PYLCs Constructed in Accordance with the Code.....	154
4.0	CONDITIONS OF ASSIGNMENT	154
4.1	General.....	154
4.2	Hatchways and Skylight Hatches.....	154
4.2.1	General requirements	154
4.2.2	Hatchways Open at Sea.....	154
4.3	Doorways and Companionways Located Above the Weather Deck for PYLCs Category 0 and 1.....	155
4.4	Skylights for PYLCs Category 0 and 1.....	156
4.5	Glazed Openings.....	157
4.6	Ventilators and Exhausts for PYLCs Category 0 and 1	158
4.7	Air Pipes for PYLCs Category 0 and 1.....	158
4.8	Scuppers, Sea Inlets, and Discharges.....	159
4.9	Materials for Valves and Associated Piping.....	159
4.10	Underwater Lights	160
4.11	Water Freeing Arrangements for PYLCs Category 0 and 1	160
4.12	Bulwarks and Guard Rails	160
4.13	General Equivalence	161
5.0	STABILITY – INTACT AND DAMAGED.....	161
5.1	General.....	161
5.2	Intact Stability.....	162

5.2.1	Motor Yachts.....	162
5.2.2	Equivalent Stability Standards.....	163
5.2.3	High Speed Yachts.....	163
5.2.4	Sailing Yachts.....	163
5.3	Damaged Stability.....	163
5.4	Elements of Stability.....	165
5.5	Stability Documents.....	165
5.6	Major Refit or Alterations.....	166
6.0	SAILING YACHT RIGGING.....	166
6.1	General.....	166
6.2	Masts and Spars.....	167
6.3	Running and Standing Rigging.....	167
6.4	Sails.....	167
7.0	FIRE SAFETY AND PREVENTION.....	168
7.1	Stowage of Gasoline, Aviation Fuel, and Other Highly Flammable Liquids.....	168
7.1.1	Portable containers including portable tanks.....	168
7.1.2	Permanent Tanks.....	168
7.1.3	Spaces designed to contain vehicles.....	170
7.2	Fire Control Plans.....	171
7.3	Ventilation.....	172
7.4	Means of Escape.....	174
7.5	Open Flame Gas Appliances and Recreational Fire Appliances.....	175
7.6	Paints, Varnishes, and Other Finishes.....	175
7.7	Fire Detection and Fire Alarm Systems.....	175
8.0	MACHINERY FOR PYLCS OF 300 GT AND ABOVE.....	176
8.1	General Requirements.....	176
8.2	Installation.....	176
8.3	Steering Gear.....	178
8.3.1	Steering Systems.....	178
8.3.2	Emergency Steering.....	178
8.4	Bilge Pumping Arrangements.....	178
8.4.1	Pumps.....	178
8.4.2	Periodically Unmanned Machinery Spaces.....	178
8.4.3	Pumping and Piping Arrangements.....	179
8.5	Electrical Installations.....	180
8.5.1	Installation.....	180
8.5.2	Emergency Sources of Power.....	181
8.5.3	Emergency Lighting.....	182
8.5.4	Batteries.....	182

	8.5.5 Battery Systems for (hybrid) propulsion.....	182
9.0	FIRE-FIGHTING EQUIPMENT FOR PYLCS	183
9.1	General Requirements.....	183
9.2	Specific Requirements	183
	9.2.1 Fire Pumps	183
	9.2.2 Fire Main and Hydrants	184
	9.2.3 Fire Hoses and Nozzles.....	185
	9.2.4 Portable Fire Extinguishers for Use in the Accommodation and Service Spaces	185
	9.2.5 Fire Extinguishing in Machinery Spaces	186
	9.2.6 Additional Fire Appliances	187
10.0	LIFE-SAVING APPLIANCES.....	188
10.1	General Requirements.....	188
	10.1.1 Life-Saving Appliances	188
	10.1.2 Launching Appliances	190
10.2	Equipment Carriage Requirements.....	190
	10.2.1 Life Rafts.....	190
	10.2.2 Recovery of Persons from the Sea.....	191
	10.2.3 Rescue Boats.....	192
	10.2.4 Life Buoys	193
	10.2.5 Lifejackets	194
	10.2.6 Immersion Suits.....	194
	10.2.7 Pyrotechnics	195
	10.2.8 Line Throwing Appliances	195
	10.2.9 Emergency Position-Indicating Radio Beacon (EPIRB).....	195
	10.2.10 Search and Rescue Transponder (SART).....	195
	10.2.11 General Alarm	195
	10.2.12 Lighting	196
	10.2.13 Life-Saving Signals and Rescue Poster.....	196
11.0	NAVIGATIONAL LIGHTS, SHAPES, AND SOUND SIGNALS.....	196
11.1	General.....	196
12.0	NAVIGATIONAL AND BRIDGE EQUIPMENT AND BRIDGE VISIBILITY	196
12.1	Requirements	196
12.2	Navigational Equipment Requirements	197
	12.2.1 Standard Magnetic Compass	197
	12.2.2 Global Navigation Satellite System (GNSS).....	198
	12.2.3 Automatic Identification System (AIS).....	198
	12.2.4 Long-Range Identification and Tracking (LRIT) System	199
	12.2.5 9 GHz Radar (X-Band).....	199

12.2.6	Nautical Charts and Nautical Publications or Electronic Chart Display and Information System (ECDIS)	199
12.2.7	Speed and Distance Measuring Device	199
12.2.8	Echo Sounder.....	199
12.2.9	Signaling Lamp.....	199
12.2.10	Searchlight.....	199
12.2.11	Instruments	199
12.2.12	Radar Reflector.....	200
12.3	Bridge Navigational Watch Alarm System (BNWAS).....	200
12.4	Bridge Visibility	200
13.0	RADIO	200
13.1	General.....	200
13.2	Sources of Energy.....	202
13.3	Watches.....	202
13.4	Radio Personnel	202
13.5	Global Maritime Distress and Safety System (GMDSS) Logbooks.....	202
14.0	PUBLICATIONS	202
15.0	DECK EQUIPMENT FOR YACHTS OF 300 GT AND ABOVE	203
15.1	Equipment.....	203
15.2	Anchors.....	203
15.3	Sailing Yachts.....	204
15.4	Towing Arrangements	204
16.0	MEDICAL STORES	204
16.1	General.....	204
17.0	YACHT-SHORE TRANSFER	204
17.1	Tenders.....	204
17.2	Pilot Transfer Arrangements for PYLCs	205
18.0	HELICOPTER AND LANDING FACILITIES	205
19.0	SUBMERSIBLES	206
19.1	General Requirements.....	206
19.2	Lifting Appliances and Attachments	206
19.3	Operation	206
20.0	SAFE WORKING PRACTICES.....	206
20.1	Safe Work Aloft, Over the Side, at Heights, and on the Bowsprit of Sailing Yachts.....	206
20.2	Man-riding Cranes	208
20.3	Training Manual	209
20.4	Instructions for On Board Maintenance.....	209
20.5	Safety Management System (SMS).....	210
21.0	PASSENGERS	210

21.1	Limitations.....	210
22.0	MANNING	210
22.2	Minimum Safe Manning.....	210
22.3	Crew Certification.....	210
CHAPTER V: YACHTS ENGAGED IN TRADE (YETS).....		211
1.0	STATUTORY AND NATIONAL REQUIREMENTS.....	212
ANNEXES		213
ANNEX 1: MINI-SAFETY MANAGEMENT SYSTEM FOR YACHTS OF LESS THAN 500 GT		214
1.0	Introduction.....	214
2.0	General.....	214
3.0	Health, Safety, Security, and Environmental Protection Policy	216
4.0	Responsibilities and Authority.....	216
5.0	Resources, Personnel, and Training.....	216
6.0	Onboard Procedures.....	217
7.0	Emergency Preparedness	217
8.0	Reporting of Accidents	218
9.0	Maintenance of the Yacht and Its Equipment.....	218
10.0	Compliance Verification, Review, and Evaluation.....	218
ANNEX 2: HELICOPTER AND LANDING FACILITIES.....		219
1.0	General.....	219
2.0	Certification	219
3.0	Fire-Fighting.....	220
3.1	Primary Fire Extinguishing Agent – Foam	220
3.2	Complementary Fire Extinguishing Agents.....	222
4.0	Operations.....	223
ANNEX 3: SIMPLIFIED TONNAGE MEASUREMENT METHOD		225
1.0	Applicability	225
2.0	Definitions – <i>for the purpose of this simplified measurement scheme only</i>	225
3.0	Measurements	226
4.0	Calculations	226
5.0	Multihull Yachts	226
6.0	Deck Structures.....	227
ISSUE AND REVISION HISTORY		228

CHAPTER I:
**INTRODUCTION, GENERAL APPLICATION,
AND DEFINITIONS**

1.0 INTRODUCTION

The Republic of the Marshall Islands (RMI) Commercial Yacht Code was originally published in October 2008. It was based on regulatory standards available to the industry at the time of its writing and was developed to address the incompatibility of certain merchant ship standards with the intended use, scope of operations, and safety needs particular to yachts.

The 2008 RMI Commercial Yacht Code was replaced in its entirety by the RMI Yacht Code published in June 2013 (hereinafter, “the Code” or “this Code”). The Code was developed to further address the design, size, and technological advances which had taken place within the yachting industry and to further ensure the safety and protection of all persons on board yachts and the marine environment.

This 2021 Code was further updated to incorporate all Yacht Code Supplements issued as amendments to the previous Code, as well as additional technical and safety updates. These include structural fire protection for yachts of less than 500 gross tonnage (GT) assigned with Category 2 notation, rescue boat requirements for yachts less than 500 GT, alternative standards for firefighting equipment for smaller sized yachts, new requirements for modern design elements such as underwater glazing for observation lounges and glazed bulwarks, and an updated standard for Helicopter Landing Areas as provided in [Annex 2](#), among others.

The Code outlines the requirements for the construction, machinery, equipment, and stability of yachts registered in the RMI. Further, this Code, in conjunction with the relevant international conventions to which the RMI is a party and applicable RMI laws or regulations, establishes the standards and substantial equivalencies for safety, security, pollution prevention, and seafarer accommodations appropriate to the size of the yacht, taking into consideration instances where it is not reasonable or practicable to comply fully with international conventions or RMI laws or regulations.

This Code is periodically revised by the RMI Maritime Administrator (hereinafter, the “Administrator”) in accordance with existing international conventions and codes to which the RMI is a party to the extent that it is reasonable and practicable to apply them, RMI laws and regulations, as well as practical experience.

Compliance with the Code does not obviate the need for compliance, where applicable, with the RMI Maritime Act 1990 (hereinafter, the “Maritime Act”); the RMI Maritime Regulations; RMI Marine Notices and Technical Circulars; other Administrator polices or requirements; and/or local authorities’ licensing, permitting, chartering, or other regulatory requirements.

The RMI has submitted this Code, as amended, to the Secretary-General of the International Maritime Organization (IMO) as an equivalent arrangement as it applies to yachts under the provisions of the International Convention for the Safety of Life at Sea (SOLAS); International Convention for the Prevention of Pollution from Ships

(MARPOL); International Convention on Load Lines, 1966 (ILLC); International Convention on Tonnage Measurement of Ships, 1969 (ITC); and the International Convention on Standards of Training, Certification and Watchkeeping for Seafarers 1978, as amended (STCW). Reference may be made through the IMO Global Integrated Shipping Information System (GISIS).

2.0 GENERAL

2.1 Application

2.1.1 Effective Date

- .1 This Code became effective June 2013. The current revision of the Code shall take effect immediately upon its publication on 11 May 2021, subject to supplements per §2.1.1.2 below.
- .2 This Code contains updates through the effective date listed in §2.1.1.1 above and may be amended by supplements published by the Administrator from time-to-time. Such supplements shall be deemed to be incorporated into this Code and shall take full force and effect as of the date of their publication or as of a future effective date if stated in the supplement.

2.1.2 Commercial Yachts

All commercial yachts, regardless of GT, shall comply with [Chapters I](#) and [II](#) of the Code.

2.1.3 Passenger Yachts (PAXYs)

All PAXYs, regardless of GT, shall comply with [Chapters I](#) and [III](#) of the Code.

2.1.4 Private Yachts Limited Charter (PYLCs)

All PYLCs shall comply with [Chapters I](#) and [IV](#) of the Code.

2.1.5 Yachts Engaged in Trade (YETs)

- .1 All private yachts that have been authorized by the Administrator to operate as a YET shall comply with [Chapters I](#) and [V](#) of the Code.
- .2 All private yachts that have been certified by a Classification Society as a passenger yacht or passenger ship and authorized by the Administrator to operate as a YET shall comply with Chapters I and III of the Code.

2.2 **Responsibility**

It is the responsibility of the owner or the owner's representative to ensure that a yacht is properly maintained, inspected, and certified in accordance with the Code and all other applicable RMI laws and regulations.

2.3 **Equivalent Standards**

- .1 The Administrator acknowledges that a yacht may have been designed and/or constructed to standards other than as provided in this Code. Such standards may provide levels of safety, suitability, and fitness of purpose equivalent to the requirements of this Code. Accordingly, the owner or authorized representative may apply to the Administrator for consideration of such standards, in whole or in part, as an equivalent to the requirements of this Code and other Administrator requirements or standards.
- .2 Exemptions and Equivalencies:
 - (a) To the extent provided for herein, exemptions and/or equivalencies to the provisions of the Code are to be authorized by the Administrator at its sole discretion.
 - (b) A recommendation for an exemption or equivalency shall be made to the Administrator by the Recognized Organization (RO) certifying the yacht. The *Application Form for RMI Yacht Code Exemptions and Equivalencies* (YTEC-02) shall be used in making the recommendation. It shall provide evidence to support the recommendation, including, but not limited to:
 - (i) reasons why application of the Code is impractical;
 - (ii) confirmation that the proposal does not adversely affect, or decrease, the safety of the persons on board the yacht;
 - (iii) drawings; and
 - (iv) where deemed necessary, an evaluation of the engineering analysis to the satisfaction of the RO.

2.4 **Operational Limitations**

- .1 Subject to the suitability for intended use, and degree of compliance with the Maritime Act ([MI-107](#)), Maritime Regulations ([MI-108](#)), and this Code, a commercial yacht, PAXY, or PYLC may be considered for the issuance of a Certificate of Registry (COR) or in the case of a YET, may be considered for the issuance of a Temporary COR, allowing it to operate under one of the following Operating Categories:
 - (a) Category 2 - up to 60 nautical miles (NM) from a safe haven;

- (b) Category 1 - up to 150 NM from a safe haven; or
- (c) Category 0 - unrestricted service.

These categories will be assigned by the Administrator based on the level of compliance as specified in the applicable sections of this Code and by any limitations provided by the RO.

The operational limitations are based on operations outside polar regions. Yachts which intend to operate in polar regions shall comply with §2.4.4 below.

- .2 Depending on the yacht and its intended use, a yacht may be restricted to less than the above specified limits. All limitations or restrictions will be recorded on the Compliance Certificate.
- .3 In order to be assigned a particular Operating Category, a yacht shall comply with all the specific requirements for that Operating Category to the satisfaction of the Administrator. Yachts are prohibited from exceeding the specified operational limitations, unless authorized by the Administrator.
- .4 Polar Regions Operations:
 - (a) Yachts to which the International Code for Ships Operating in Polar Waters ([Polar Code](#)) applies and that are operating in polar regions shall meet the applicable requirements, including those of the Classification Society.
 - (b) In addition to §2.4.4a above, the following IMO publications shall be used as guidance:
 - (i) IMO Resolution [A.1024\(26\) and Corr.1](#), *Guidelines for Ships Operating in Polar Waters*;
 - (ii) IMO Circular [MSC.1/Circ.1185/Rev.1](#), *Guide for Cold Water Survival*; and
 - (iii) IMO Resolution [A.999\(25\)](#), *Guidelines on Voyage Planning for Passenger Ships Operating in Remote Areas*.

2.5 Coastal State Requirements

Coastal States may impose additional requirements on yachts entering or within their sea areas, ports, and harbors. All RMI registered yachts shall comply with these local requirements, as applicable.

2.6 **Name and Port of Registry**

The Port of Registry may be either Jaluit or Bikini. The name and Port of Registry of the yacht shall be permanently marked on the stern of the yacht and shall be in a contrasting color and distinctly visible. The letters or symbols shall not be less than 150 millimeters (mm) in height.

2.7 **Administrator Notices, Advisories, and Circulars**

- .1 The Administrator publishes various documents in order to clarify its policies and requirements regarding international conventions and codes and national laws and regulations, or to bring relevant issues, such as piracy or increased port State control inspections in various ports, to the attention of RMI registered yachts, shipowners, and operators. These publications include, but are not limited to:
 - (a) Marine Notices (MNs);
 - (b) Marine Guidelines (MGs);
 - (c) Technical Circulars (TCs);
 - (d) Marine Safety Advisories (MSAs);
 - (e) Ship Security Advisories (SSAs);
 - (f) Yacht Safety Advisories (YSAs); and
 - (g) Yacht Technical Circulars (YTCs).
- .2 The declared compliance, the length, and/or GT shall be used to determine the applicability of these publications.
- .3 The most up-to-date version of these publications and many others can be found at: www.register-iri.com. However, the Administrator also sends all updates via email. Therefore, it is of the utmost importance to ensure that any changes in contact details be submitted to the Administrator using the *Declaration of Company* ([MI-297A](#)) and/or *Combined Declaration* ([MI-297B](#)) forms, as applicable, via the general yacht email address at yachts@register-iri.com.

2.8 **Yacht Contact Email Addresses**

In an effort to expedite incoming inquiries, requests, and notifications, the Administrator has created yacht specific contact email addresses. See the Administrator's [Yacht Contacts](#) page.

2.9 Yachts Taking Part in Races

For the requirements for yachts whilst racing or whilst in passage directly to or from a race, see *Requirements for Yachts Participating in Races* ([MN 2-011-48](#)).

2.10 Carriage of Supernumeraries

Carriage of supernumeraries, as defined in §3.0 of this Chapter, in addition to the crew, is permissible subject to the provision of sufficient life-saving appliances and appropriate accommodations. Supernumeraries shall undergo onboard familiarization training and shall not be assigned to duties on the muster list for any emergency related functions.

3.0 DEFINITIONS

The following definitions apply to terms as used throughout this Code:

“2010 FTP Code” means the International Code for the Application of Fire Test Procedures, 2010 as defined in SOLAS II-2, as amended;

“Administrator” means the RMI Maritime Administrator;

“Administrator or its representative” means the Administrator or an RO, as appropriate;

“AFS Convention” means the International Convention on the Control of Harmful Anti-fouling Systems on Ships;

“Appointed Representative (AR)”¹ means an Administrator appointed agent or representative who conducts statutory surveys of unclassified yachts for the issuance of statutory certificates; initial, annual, and renewal surveys and Compliance Verifications; and other services in accordance with written agreement;

“Approved Type” means, with respect to materials or equipment, that it is accepted by the Administrator on the basis of the approval of such materials or equipment by another administration or an organization that is formally recognized by the Administrator;

“Aviation Fuel” means fuel used for aircraft engines;

¹ For additional details see *Organizations Acting on Behalf of the RMI Maritime Administrator* ([MG 2-11-15](#)).

“Aviation Inspection Body (AIB)”² means an authority recognized by the Administrator responsible for the verification and certification of helicopter landing areas;

“Bridge” means the control station occupied by the officer of the watch who is responsible for the safe navigation of the yacht;

“BS” means the British Standards;

“Bulkhead deck” means the uppermost continuous deck of a yacht to which all main transverse watertight bulkheads are carried;

“Charter” means an agreement between the owner or managing agent and another party that allows that party, referred to as the “charterer,” to use the yacht;

“Classed yacht” means a yacht that has been issued and maintains a valid Certificate of Classification for hull and machinery by a Classification Society;

“Classification Society” or **“Class”³** means an organization that establishes and applies technical standards in relation to the design, construction, and survey of marine vessels. Only those Classification Societies that have been approved as an RO by the Administrator may carry out services under the RMI Yacht Code for an RMI flagged yacht;

“Code” means the RMI Yacht Code ([MI-103](#));

“Commercial yacht” means any yacht registered as per Chapter 2, Part V, of the RMI Maritime Act ([MI-107](#)) that is described on the COR as a commercial yacht and therefore may be engaged in trade, commerce, or chartered carrying no more than 12 passengers;

“Compartment” means all living and working spaces easily accessible from one to another on any one level;

“Compliance Certificate” means a national certificate that confirms that the yacht meets the applicable requirements of the RMI Yacht Code;

“Compliance Verification” means an initial, annual, or renewal inspection carried out by an AR to verify that the qualifications and certification of the crew and the actual condition of the yacht and the certificates issued to it are in compliance with the requirements of the RMI Yacht Code and any international conventions, as applicable;

² For additional details see [MG 2-11-15](#).

³ For additional details see [MG 2-11-15](#).

“Control stations” mean those spaces in which the yacht’s radio or main navigating equipment or the emergency source of power are located or where the fire recording or fire control equipment is centralized;

“COR” means Certificate of Registry;

“Crew” means collectively the persons other than officers, or the Master, serving in any capacity on board a vessel;

“Daughter craft” means any watercraft associated with a “parent” yacht, which is towed by or carried on the parent yacht but is not issued with its own Certificate of Registry;

“Deadlight” means a watertight cover fitted to the inside of windows and side scuttles;

“Down-flooding angle” is the angle of heel at which openings in the hull, superstructure, or deckhouses, which cannot be closed weather-tight, immerse. Small openings through which progressive flooding cannot take place need not be considered as open;

“Efficient” in relation to a fitting, piece of equipment, or material, means that all reasonable and practicable measures have been taken to ensure that it is suitable for the purpose for which it is intended to be used;

“Emergency source of electrical power” means a designated source of electrical power intended to supply the emergency switchboard in the event of failure of the main source of electrical power;

“Emergency switchboard” means a switchboard that, in the event of failure of the main electrical power supply system, is directly supplied by the emergency source of electrical power or the transitional source of emergency power and is intended to distribute electrical energy to the emergency services;

“EN” means the European Norm;

“EPIRB” means a satellite emergency position-indicating radio beacon, being an earth station in the mobile-satellite service, the emissions of which are intended to facilitate search and rescue operations, complying with performance standards adopted by the IMO, and is capable of:

- (a) floating free and automatically activating if the yacht sinks;
- (b) being manually activated; and
- (c) being carried by one person;

“Excursion” means a trip of limited duration, operating in a restricted area within close proximity to shore originating from the nominated departure point, in favorable weather conditions, and subject to sufficient life-saving appliances being provided. No passengers would be berthed overnight on board during this time;

“Float-free launching” means that method of launching a life-saving appliance whereby it is automatically released from a sinking yacht and is ready for use and/or activated;

“Freeboard” means the distance measured vertically downwards amidships from the upper edge of the deck line to the upper edge of the related load line;

“Freeboard deck” means, as defined in Annex I of the ILLC, the deck that is normally the uppermost complete deck exposed to the weather and sea, which has permanent means of closing all openings in the weather part thereof, and below which all openings in the sides of the yacht are fitted with permanent means of watertight closing;

“FSS Code” means the International Code for Fire Safety Systems, as defined in SOLAS II-2;

“Garbage” means all kinds of victual, domestic, and operational waste as defined in MARPOL Annex V, excluding fresh fish and parts thereof, generated during the normal operation of the yacht and liable to be disposed of continuously or periodically from a yacht;

“GNSS” means Global Navigation Satellite System as defined in SOLAS V/19;

“Gross tonnage (GT)” unless otherwise specified, means the gross tonnage calculated in accordance with the tonnage measurement regulations contained in Annex I to the ITC, or any successor convention; the gross tonnage for vessels covered by the tonnage measurement interim scheme adopted by the IMO will be the gross tonnage which is included in the REMARKS column of the International Tonnage Certificate;

“Hazardous space” means a space or compartment in which combustible or explosive gases or vapors are liable to accumulate in dangerous concentrations;

“Helicopter Landing Area (HLA)” means a designated area and associated facilities certified for intended landing or take off of a helicopter;

“Helicopter Landing Area Technical Certificate (HLATC)” means a certificate issued by an AIB to confirm the helideck and associated facilities meet the minimum physical characteristics required in accordance with this Code;

“HSC 2000 CODE” means the International Code of Safety for High-Speed Craft, 2000.

“**ILLC**” means the International Convention on Load Lines, 1966, as amended;

“**ILO**” means the International Labour Organization, a specialized agency of the United Nations;

“**Immersion suit**” means a protective suit as defined in the International Life-Saving Appliance (LSA) Code Chapter II, as amended, which reduces the body heat loss of a person wearing it in cold water;

“**IMO**” means the International Maritime Organization, a specialized agency of the United Nations;

“**International convention or code**” means any international framework for the design or operation of a vessel that the RMI is a party to and with which it requires vessels under its flag to comply;

“**International voyage**” means a voyage outside the territorial waters of the RMI;

“**IS Code**” means the International Code on Intact Stability, 2008, as amended;

“**ISM Code**” means the International Safety Management Code, as amended;

“**ISO**” means the International Standards Organization;

“**ISPS Code**” means the International Ship and Port Facility Security Code, as amended;

“**Launching appliance**” means a provision for safely transferring a lifeboat, rescue boat, life raft, or inflated boat, from its stowed position to the water and recovery where applicable;

“**Length**” means, unless specified otherwise, Load Line Length;

“**Length Overall (LOA)**” means the distance from the forward side of the stem to the aftermost side of the stern;

“**Lifeboat**” means a lifeboat complying with Chapter IV of the LSA Code;

“**Life buoy**” means a life buoy complying with Chapter II of the LSA Code;

“**Life jacket**” means a life jacket complying with Chapter II of the LSA Code;

“**Life raft**” means a life raft complying with Chapter IV of the LSA Code;

“**Line throwing appliance**” means an appliance complying with Chapter VII of the LSA Code;

“Load Line Length” means, as defined in Annex I of the ILLC, the length which shall be taken as 96% of the total length on the waterline of a yacht at 85% of the least molded depth measured from the top of the keel, or the length from the foreside of the stem to the axis of the rudder stock on that waterline, if that be greater. See following figure;

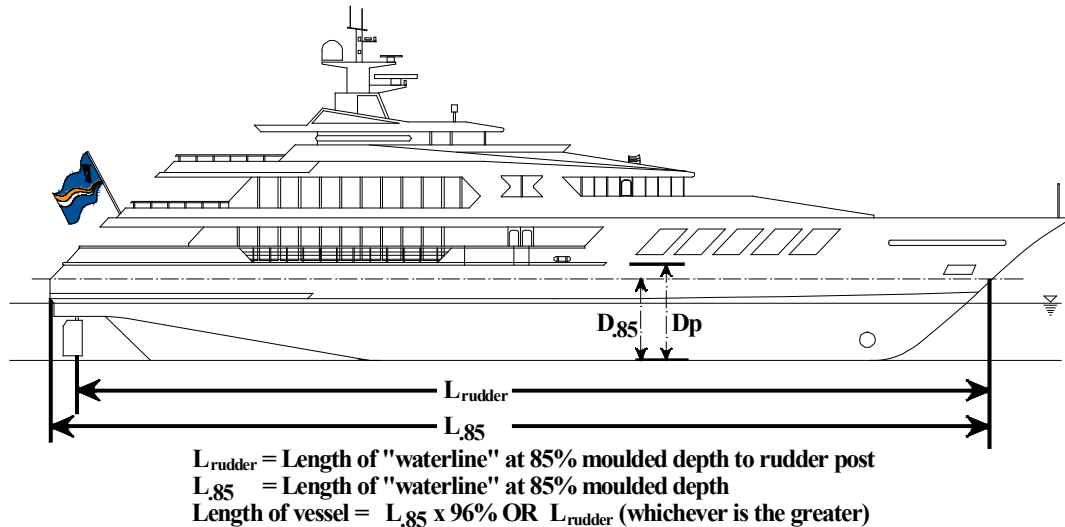

“Low flame spread” means that the surface thus described will adequately restrict the spread of flame, this being determined in accordance with the 2010 FTP Code;

“LSA Code” means the International Life-Saving Appliances Code, as amended;

“Machinery spaces” means all machinery spaces of Category A and all other spaces containing propelling machinery, boilers, oil fuel units, steam and internal combustion engines, generators and major electrical machinery, oil filling stations, refrigerating, stabilizing, ventilation and air conditioning machinery, and similar spaces, and trunks to such spaces;

“Machinery spaces of Category A” means those spaces and trunks to such spaces that contain:

- (a) internal combustion machinery used for main propulsion; or
- (b) internal combustion machinery used for purposes other than main propulsion where such machinery has in the aggregate a total power output of not less than 375 kilowatts (kW); or
- (c) any oil fuel unit;

“Main source of electrical power” means a designated source intended to supply electrical power to the main switchboard for distribution to all services necessary for maintaining the yacht in normal operational and habitable condition;

“Main steering gear” means the machinery and any related appurtenances used for the steering of the yacht under normal service conditions;

“Main switchboard” means a switchboard that is directly supplied by the main source of electrical power and is intended to distribute electrical energy during normal operational and habitable condition;

“Main vertical zone” means those sections into which the hull, superstructure, and deckhouses are divided by “A” class divisions, the mean length of which on any deck does not exceed 48 meters (m);

“Major conversion” means something that in the opinion of the Administrator:

- (a) substantially alters the dimensions or carrying capacity of the yacht; or
- (b) changes the original intent of the design of the yacht; or
- (c) which otherwise so alters the yacht that it would become subject to the relevant provisions of the Code;

“Major refit” or “Major alteration” means either a change in the lightship displacement of 2% and above and/or lightship longitudinal center of gravity of 1% and above (measured from the aft perpendicular) and/or the calculated lightship vertical center of gravity rises by 0.25% and above (measured from the keel);

“Man-riding Crane” means a crane that is used for the lifting of equipment or craft with personnel in it;

“Maritime Regulations” means the RMI Maritime Regulations ([MI-108](#));

“MARPOL” means the International Convention for the Prevention of Pollution from Ships, 1973, and its 1978 Protocol, as amended;

“Master” means the Captain in command of the yacht;

“Maximum ahead service speed” means, for the purpose of steering gear and rudder stock and pintle design, the maximum contractual speed of the yacht, in knots;

“Motor yacht” means a yacht which is described on the COR as such, and which has as a sole means of propulsion from either one or more power units;

“MLC, 2006” means the Maritime Labour Convention, 2006;

“Multihull yacht” means any yacht that in any normal operating trim or heel angle has a rigid hull structure that penetrates the surface of the water over more than one separate or distinct area;

“Nautical mile (NM)” means 1,852 m or 6,076 feet (ft);

“Not readily ignitable” means that the surface thus described will not continue to burn for more than 20 seconds after removal of a suitable impinging test flame;

“Officer” means a seafarer who is required to be qualified under the STCW;

“Passenger” means a person carried on a vessel except:

- (a) a person employed or engaged in any capacity on the business of the vessel;
- (b) a person on board the vessel either in pursuance of the obligation laid upon the Master to carry shipwrecked, distressed or other persons, or by reason of any circumstance that neither the Master nor the owner nor the charterer, if any, could have prevented or forestalled;
- (c) a child under one year of age; or
- (d) a social guest;

“Passenger ship” means a ship carrying more than 12 passengers for consideration;

“Passenger Yacht (PAXY)” means any passenger ship registered as per Chapter 2 of the RMI Maritime Act ([MI-107](#)) that is described on the COR as a passenger yacht and therefore may be engaged in trade, commerce, or chartering carrying more than 12 but no more than 36 passengers under limited operational conditions;

“Position 1” means upon exposed freeboard and raised quarter decks and upon exposed superstructure decks situated forward of a point located a quarter of the yacht’s length from the forward perpendicular;

“Position 2” means upon exposed superstructure decks situated abaft a quarter of the yacht’s length from the forward perpendicular;

“Power actuating system” means the hydraulic equipment provided for supplying power to turn the rudder stock, comprised of a steering gear power unit or units, together with the associated pipes and fittings, and a rudder actuator. The power actuating systems may share common mechanical components, i.e., tiller, quadrant, and rudder stock, or components serving the same purpose. Related equipment used for alternative means of steering on yachts that, for example, use impellers for propulsion, are included;

“Private Use” means that the private yacht is used on a private voyage or excursion, and during such use is not engaged in trade by transporting merchandise or carrying passengers for reward or remuneration (other than as a contribution to the actual cost of the yacht or its operation for the period of the voyage or excursion, cumulatively for not more than 84 days per calendar year, where the private yacht has met the requirements of and is certified as a Private Yacht Limited Charter or a Yacht Engaged in Trade);

“Private yacht” means any yacht 12 m or more in length not carrying passengers for hire, not engaged in trade or commerce, and being used solely for pleasure or recreational purposes of its owner, which, at the time it is being used, is:

- (a) in the case of a yacht owned by a corporate entity, one on which the persons on the yacht are employees, officers, directors, or beneficial owners of the corporate entity, or their immediate family or friends; or
- (b) in the case of other ownership arrangements, one on which the persons on board the yacht are beneficiaries under the trust or the employees, officers, beneficial owners, or persons with similar designations of the ownership arrangement, or their immediate family or friends; or
- (c) in private use;

“Private Yacht Limited Charter (PYLC)” means a private yacht 18 m or more in length overall and less than 500 GT registered as per Chapter 2, Part V, of the RMI Maritime Act ([MI-107](#)) that is described on the COR as a private yacht and holds a valid Private Yacht Limited Charter Compliance Certificate, allowing the yacht to be engaged in limited chartering for no more than 84 days per calendar year and which shall carry no more than 12 passengers;

“Qualified Individual (QI)” means an individual or entity which, upon evidence of relevant and sufficient experience, is deemed qualified in writing by the Administrator to carry out pre-registration inspections and tonnage measurements for unclassed private yachts of less than 24 m in length;

“Rating” means a member of the crew (see definition of “Crew” above);

“Recess” means an indentation or depression in a deck and which is surrounded by the deck and has no boundary common with the shell of the yacht, e.g., a hot tub or spa;

“Recognized Organization (RO)” means an entity: 1) delegated authority to act on behalf of the Administrator with respect to statutory certification and services; and 2) if a Classification Society, has been assessed by the Administrator and found to comply with the RO Code or if an AR, has been assessed by the Administrator and found to substantially comply with the RO Code;

Recreational Fire Appliances (RFAs) mean fire appliances which use wood, ethanol, or liquified petroleum gas (LPG) as a primary fuel source or for ignition purposes and include charcoal galley ovens, LPG or charcoal fire barbeques, spit roasts, and fire pits;

“Representative” means an individual or entity whereby, through written agreement, they may perform certain tasks as delegated to them through the agreement or may provide and agree to certain items as specifically mentioned in this Code;

“Rescue boat” means a boat complying with Chapter V of the LSA Code;

“RMI” means the Republic of the Marshall Islands;

“RO Code” means the Code for Recognized Organizations;

“Rules of Class” means the rules for the construction of yachts as established and used by a Classification Society for the purpose of classification;

“Safe haven” means a harbor or shelter of any kind that affords entry, subject to prudence in the weather conditions prevailing, and protection from the force of the weather;

“Sailing yacht” means a yacht designed to carry sail as a primary means of propulsion regardless of whether or not auxiliary means exist;

“Search and Rescue Transponder (SART)” means a device designed for use in survival craft to facilitate location of survival craft in search and rescue operations by radar and should comply with IMO Resolution [A.802\(19\)](#), *Performance Standards for Survival Craft Transponders for use in Search and Rescue Operations*, as amended by IMO Resolution [MSC.247\(83\)](#);

“Seafarers” means those persons who are employed, engaged, or work in any capacity on board any vessel unless specified otherwise;

“Side scuttle” means an ISO standardized type of round ship’s window with or without a deadlight (ISO 6345:1990) that is of an opening (hinged) or non-opening type;

“Similar stage of construction” means at a stage which:

- (a) construction identifiable with a specific vessel begins;
- (b) assembly of that yacht, comprising at least 1% of the estimated mass of all structural material has commenced, excluding fiberglass reinforced plastic (FRP) or glass reinforced plastic (GRP); and
- (c) in the case of yachts constructed of FRP or GRP, the date when more than 3% of the hull resin and reinforcement has been laid;

“Social guest” means a person who has been invited on board a private yacht by the owner for which no reward or remuneration is given;

“SOLAS” means the International Convention for the Safety of Life at Sea, 1974, and the 1988 Protocol, as amended;

“Statement of International Convention Voluntary Compliance” means a document attesting that the yacht is in substantial compliance to the satisfaction of the Administrator to an international code or convention that it is not required to abide by, but is doing so on a voluntary basis;

“STCW” means the International Convention on Standards of Training, Certification and Watchkeeping for Seafarers 1978, as amended;

“Steering gear power unit” means:

- (a) in the case of electric steering gear, an electric motor and its associated electrical equipment;
- (b) in the case of electrohydraulic steering gear, an electric motor and its associated electrical equipment and connected pump; and
- (c) in the case of other hydraulic steering gear, a driving engine and connected pump;

“Storm cover” means a cover fitted to the outside of windows and side scuttles;

“Strum box” means a perforated metal box fitted around a bilge suction pipe opening to prevent debris from choking the pipe;

“Submersible” means a manned craft able to be submerged and capable of operating under water for short periods;

“Supernumerary” means a person engaged on board a vessel, employed by either the owner or charterer in connection with business interests of the vessel or in relation to social activities on board. Such persons include nannies, security guards, entertainers, butlers, and similar support personnel and are not considered passengers or crew members;

“Superstructure” means the definition as described in Annex I of ILLC;

“Survival craft” means a craft capable of sustaining the lives of persons in distress from the time of abandoning the yacht that meets the requirements of Chapter IV of the LSA Code;

“Tender” means a rigid or inflatable boat carried on or towed by a yacht for the purpose of transporting persons to and from the shore or between other vessels;

“Tender Statement of Compliance (TSC)” means a document issued by an AR to a tender to a commercial yacht, PAXY, PYLC, or YET stating that the tender meets a substantial safety standard as required by this Code;

“To sea” means beyond any partially smooth waters, or smooth waters limits that may have been designated by the authority in which the yacht is operating. In the event that no such areas have been designated, then it means that the yacht is considered to have proceeded beyond the immediate confined designated harbor;

“Training manual” means, with regard to life-saving appliances, a manual complying with the requirements of Chapter II, §[27.4](#) and Chapter IV, §[20.3](#) of this Code;

“Vessel” means any yacht;

“Very high frequency (VHF) radiotelephone” means a portable or a fixed VHF installation for survival craft complying with the performance adopted by the IMO in Resolution [A.762\(18\)](#), *Performance Standards for Survival Craft Two-Way VHF Radiotelephone Apparatus* as amended;

“Void space” means any space not readily accessible and serving no practical function on board the yacht and incapable of readily collecting water under normal operating circumstances;

“Voyage” means any movement of the yacht, including an excursion;

“Watertight” means having the scantlings and arrangements capable of preventing the passage of water in any direction under the head of water likely to occur in intact and damaged conditions;

“Weather deck” means a deck which is completely exposed to the weather from above and from at least two sides;

“Weather-tight” means, as defined in Annex I of ILLC, that in any sea conditions water will not penetrate into the yacht;

“Window” means any window, regardless of shape, suitable for installation aboard yachts; and

“Yacht Engaged in Trade (YET)” means a private yacht of 24 m or more in length, registered as per Chapter 2, Part V, of the RMI Maritime Act ([MI-107](#)) that is eligible to obtain a valid Temporary Certificate of Registry for Yacht Engaged in Trade and which maintains a valid Yacht Engaged in Trade Compliance Certificate, and therefore may be engaged in temporary chartering for no more than 84 days in a calendar year.

CHAPTER II: COMMERCIAL YACHTS

1.0 STATUTORY AND NATIONAL REQUIREMENTS

All commercial yachts⁴ shall comply with the requirements outlined in this Chapter II as well as the applicable requirements of [Chapter I](#) of this Code and all other applicable RMI laws and regulations.

Refer to *RMI Yacht Compliance Requirements* ([MI-103A](#)) for a comprehensive matrix of statutory and national requirements.

1.1 **Convention on the International Regulations for Preventing Collisions at Sea, 1972 (COLREGS '72)**

All yachts shall comply with the requirements of COLREGS '72.

1.2 **International Convention on Tonnage Measurement of Ships, 1969 (ITC)**

All yachts of 24 m or more in length are required to be surveyed and admeasured to the ITC and issued with an International Tonnage Certificate.

1.3 **International Convention for the Prevention of Pollution from Ships (MARPOL)**

All yachts are required to comply with the provisions of MARPOL, subject to the applicability of each Annex.

MARPOL electronic record and logbooks are permitted to be used. They shall be approved by the Administrator where required by international convention. See *Electronic Record Books and Logbook Systems* ([MN 7-041-5](#)).

Refer to *Requirements for MARPOL Surveys for All Yachts* ([MN 2-013-11](#)).

1.3.1 **MARPOL Annex I**

All yachts shall comply with the requirements of MARPOL Annex I. Yachts of 400 GT and above shall be surveyed to verify compliance and issued with the following:

- (a) International Oil Pollution Prevention Certificate (IOPPC); and
- (b) Supplement to the IOPPC; and shall maintain
- (c) an Oil Record Book (ORB)*.

**All yachts less than 400 GT shall maintain a similar ORB.*

⁴ The general term “yacht” when used throughout this Chapter shall mean a commercial yacht.

1.3.2 MARPOL Annex IV

- .1 Yachts of 400 GT and above or certified to carry more than 15 persons, regardless of tonnage, shall comply with the requirements of MARPOL Annex IV. Yachts to which Annex IV applies shall be surveyed to verify compliance and issued an International Sewage Pollution Prevention Certificate.
- .2 In certain cases, MARPOL stipulates criteria for “ships...which are certified to carry more than 15 persons.” The Administrator recognizes that this is not always applicable to all yachts due to non-mandatory requirements of certain certificates.

Therefore, for the purposes of MARPOL Annex IV, where the number of persons carried on board is a stipulated criterion, the figure to be used shall be the number shown on the Cargo Ship Safety Equipment Certificate (supplement). If the yacht is not required to hold a Cargo Ship Safety Equipment Certificate, the figure to be used shall be the number shown on the *Record of Safety Equipment - Form E* (MI-289).

1.3.3 MARPOL Annex V

- .1 All yachts shall comply with the requirements of MARPOL Annex V. Yachts of 400 GT and above and those certified to carry 15 persons or more, regardless of tonnage, shall be surveyed to verify compliance and must maintain a Garbage Record Book.
- .2 Yachts of 100 GT and above or certified to carry 15 persons or more, regardless of tonnage, are required to have a Garbage Management Plan.
- .3 In certain cases, MARPOL Annex V stipulates criteria for “every ship ...which is certified to carry 15 or more persons.” The Administrator recognizes that this is not always applicable to all yachts due to non-mandatory requirements of certain certificates.

Therefore, for the purposes of MARPOL Annex V, where the number of persons carried on board is a stipulated criterion, the figure to be used shall be the number shown on the Cargo Ship Safety Equipment Certificate (supplement). If the yacht is not required to hold a Cargo Ship Safety Equipment Certificate, the figure to be used shall be the number shown on the *Record of Safety Equipment - Form E* (MI-289).

1.3.4 MARPOL Annex VI

- .1 All yachts shall comply with the requirements of MARPOL Annex VI. Yachts of 400 GT and above are required to be surveyed to verify compliance and be issued with the following:
 - (a) International Air Pollution Prevention Certificate (IAPPC); and

- (b) Supplement to the IAPPC; and maintain an
 - (c) Ozone-Depleting Substances Record Book; and
 - (d) International Energy Efficiency Certificate (IEEC); and
 - (e) Ship Energy Efficiency Management Plan (SEEMP).
- .2 In addition, yachts that are required to comply with Regulation 13 of Annex VI shall have an Engine Technical File and an Engine IAPPC (EIAPPC) for each marine diesel engine over 130 kilowatts (kW).

1.4 Anti-Fouling

- .1 All yachts shall comply with the requirements of the International Convention on the Control of Harmful Anti-fouling Systems on Ships (AFS Convention). All yachts of 400 GT and over and engaged in international voyages shall be issued with the following:
- (a) International Anti-fouling System Certificate; and maintain a
 - (b) Record of Anti-fouling Systems.
- .2 Yachts of 24 m or more in length but less than 400 GT engaged in international voyages shall carry a Declaration on Anti-fouling Systems signed by the owner or their representative. The Declaration shall be accompanied by appropriate documentation.

1.5 International Convention for the Control and Management of Ships' Ballast Water and Sediments, 2004 (BWM Convention)

All yachts constructed to carry ballast water shall comply with the requirements of the BWM Convention.

1.6 Nairobi International Convention on the Removal of Wrecks, 2007 (WRLC)

Yachts of 300 GT and above are required to be insured and certificated under the WRLC. Refer to *Nairobi International Convention on the Removal of Wrecks, 2007 Certification Requirements* ([MN 2-011-45](#)).

1.7 International Convention on Civil Liability for Bunker Oil Pollution Damage (CLBC)

Yachts of 1,000 GT and above are required to be insured and certificated under the CLBC. Refer to *Civil Liability for Bunker Oil Pollution Damage, 2001, Certification Requirements* ([MN 2-011-27](#)).

1.8 Standards of Training, Certification and Watchkeeping for Seafarers, 1978 (STCW)

All yachts shall have a Minimum Safe Manning Certificate (MSMC) and the crew must be appropriately certified in accordance with §[29.0](#) of this Chapter.

1.9 International Convention on Load Lines, 1966 (ILLC)

All yachts shall be surveyed in accordance with the applicable provisions of the ILLC as modified by this Code and be issued with the following:

- (a) International Load Line Certificate; and maintain a
- (b) Record of Conditions of Assignment.

1.10 International Convention for the Safety of Life at Sea (SOLAS)

All yachts shall comply with the SOLAS requirements, as outlined below.

1.10.1 SOLAS Chapters II-1 and II-2: Safety Construction

Yachts of 500 GT and above are required to be surveyed under the requirements of SOLAS Chapters II-1 and II-2, as modified by this Code and issued with a Cargo Ship Safety Construction Certificate.

1.10.2 Classification and Certification

- .1 All yachts shall be able to demonstrate that their hull and machinery are built to a known high standard. This is typically accomplished by having the yacht built to the Rules of Class and issued a class certificate.
- .2 Yachts of 500 GT or more must maintain classification and statutory certification with a Classification Society. Refer to *Organizations Acting on Behalf of the Republic of the Marshall Islands Maritime Administrator* ([MG 2-11-15](#)) for a list of the Administrator recognized Classification Societies.

1.10.3 SOLAS Chapter III: Safety Equipment

Yachts of 500 GT and above are required to be surveyed under the requirements of SOLAS Chapter III, as modified by this Code and issued with the following:

- (a) Cargo Ship Safety Equipment Certificate; and maintain a
- (b) Record of Equipment for the Cargo Ship Safety Equipment Certificate (Form E).

1.10.4 SOLAS Chapter IV: Radio Communications

Yachts of 300 GT and above are required to be surveyed under the requirements of SOLAS Chapter IV, as modified by this Code and issued with the following:

- (a) Cargo Ship Safety Radio Certificate; maintain a
- (b) Record of Equipment for the Cargo Ship Safety Radio Certificate (Form R); and
- (c) Ship Radio Station License.

1.10.5 SOLAS XI-1/3: IMO Number

- .1 Yachts of 300 GT and above shall be marked with their IMO number.
- .2 The permanent marking shall be plainly visible and shall be painted in a contrasting color on a horizontal surface visible from the air.
- .3 The permanent marking referred to in §1.10.5.2 above shall be not less than 200 mm in height. The width of the marks shall be proportionate to the height.
- .4 In addition, the permanent marking shall be located in an unobstructed location on an end transverse bulkhead of the machinery space.
- .5 The permanent marking referred to in §1.10.5.4 above shall not be less than 100 mm in height. The width of the marks shall be proportionate to the height. This marking may be made by raised lettering, by cutting it in, by center punching it, or by any other equivalent method of marking the identification number which ensures that the marking is not easily expunged.
- .6 For yachts constructed of a material other than steel or metal where the requirements of marking as referred to in §1.10.5.5 above are not feasible, alternative methods of permanent marking may be approved by the Administrator.

1.11 International Safety Management (ISM) Code

- .1 Yachts of 500 GT and above are required to comply with the requirements of SOLAS Chapter IX and the ISM Code and be issued with the following:
 - (a) A copy of the Document of Compliance (DoC); and
 - (b) Safety Management Certificate (SMC).
- .2 See *International Safety Management (ISM) Code* ([MN 2-011-13](#)) for further details.

- .3 Yachts less than 500 GT are required to implement and maintain a mini-ISM system as part of their commercial yacht compliance certification. Refer to [Annex 1](#) of this Code.

1.12 International Ship and Port Facility Security (ISPS) Code

Yachts of 500 GT and over are required to comply with the requirements of SOLAS Chapter XI-2 and the ISPS Code and be issued an International Ship Security Certificate (ISSC).

See *International Ship and Port Facility Security (ISPS) Code* ([MN 2-011-16](#)) for further details.

1.13 Maritime Labour Convention, 2006 (MLC, 2006)

- .1 All yachts are required to comply with the requirements of MLC, 2006 and shall be subject to inspections to verify compliance.
- .2 All yachts of 500 GT or more shall carry on board a Maritime Labour (ML) Certificate evidencing compliance.
- .3 For yachts less than 500 GT, certification is not required, but voluntary certification is recommended.

1.14 International Code of Safety for Ships using Gases or other Low-flashpoint Fuels (IGF) Code

Where low-flashpoint fuel is used for propulsion machinery, auxiliary power generation machinery and/or other purpose machinery, the requirements of the IGF Code shall be applicable for all yachts.

1.15 Inventory of Hazardous Materials (IHM)

- .1 All yachts of 500 GT and above, irrespective of calling at a European Union (EU) Member State port or anchorage must carry on board a Statement of Compliance (SoC), supplemented by an IHM.
- .2 See *Inventory of Hazardous Materials* ([MG 2-11-9](#)) for further details.

2.0 CONVENTION SURVEYS

2.1 Survey Standards

- .1 Statutory and other certification work may be undertaken by those organizations specified in *Organizations Acting on Behalf of the Republic of the Marshall Islands Maritime Administrator* ([MG 2-11-15](#)).

- .2 Further, entities authorized by ROs to conduct in water surveys, radio surveys, etc., are also duly recognized by the Administrator.

2.2 Survey Requests

All requests for survey and certification must be made to an appropriate RO.

2.3 Statements of International Convention Voluntary Compliance

Yachts that voluntarily comply with the provisions of an international convention or code, which would not otherwise apply to the particular yacht, shall have Statements of International Convention Voluntary Compliance issued instead of convention certificates of compliance.

3.0 MAINTAINING COMPLIANCE WITH THIS CODE

3.1 General

In accordance with RMI laws and regulations, all yachts with a commercial registration shall be inspected annually by an AR, as applicable, to verify compliance with this Code. This compliance verification is in addition to, and separate from, any other inspections or surveys that may be required to meet Class or international statutory requirements.

See *Conducting Surveys and Issuing International Convention and National Certificates for Commercial Yachts, Passenger Yachts, and Yachts Engaged in Trade* ([MN 2-011-53](#)) for further guidance on compliance verification requirements.

3.2 Statutory Compliance and RMI Certification

Every yacht shall maintain valid statutory international convention certification issued by an RO and also maintain a valid RMI Commercial Yacht Compliance Certificate (CYCC).

- .1 Classed yachts shall be certified for compliance to the international statutory conventions by a Classification Society.
- .2 Unclassed yachts of less than 500 GT may be certified for compliance to the international statutory conventions by an AR.
- .3 Unclassed yachts shall be examined in accordance with the *Examination of a Yacht's Hull and Related Items* ([YTC 4](#)).
- .4 It shall be the responsibility of owners/managers and Masters to ensure that their yachts are in compliance with the requirements of all applicable international

treaties, conventions, protocols, codes, and agreements, which have come into force and to which the RMI is a party.

- .5 It is the responsibility of the owner/manager and Master to maintain the validity, and endorsement of all applicable certificates at all times. Invalidation of any certificate issued to the yacht may result in the withdrawal of the COR.
- .6 The RO shall advise the Administrator promptly, in writing, when it suspends, withdraws, cancels, or alters the operational limitations of its certificates, together with the reason(s) why such action was taken.
- .7 The RO shall promptly inform the Administrator when a yacht is found to be in operation with deficiencies or discrepancies, such that the condition of the yacht or its equipment does not meet the requirements or comply with the particulars of its certificates, the applicable international conventions, and/or RMI requirements.

3.3 Commercial Yachts Constructed in Accordance with the Code

See *Delegation of Yacht Code Compliance Reviews and Surveys of New Construction and Conversion of Yachts (YTC 2)* for the delegation of Code compliance reviews and surveys of new constructions and conversions of commercial yachts.

4.0 CONSTRUCTION

4.1 General Requirements

- .1 All yachts shall have a freeboard deck.
- .2 All yachts shall be fitted with a weather-tight deck for the length of the yacht and be of adequate strength to withstand the sea and weather conditions likely to be encountered in the declared area(s) of operation.
- .3 Hull construction material, as it relates to structural fire protection, shall comply with §[11.0](#) and §[12.0](#) of this Chapter.
- .4 Yachts of 80 m or more in length shall meet the double bottom requirements of Class. SOLAS II-1 shall be used where Class requirements are not specified.

4.2 Structural Strength

All yachts of any size shall be/have been approved to, and built in accordance with, the Rules of Class, and as such will be accepted as being of adequate strength for the service conditions covered by the classification notation.

4.3 **Watertight Bulkheads**

- .1 The strength of watertight bulkheads shall be designed and constructed in accordance with the Rules of Class.
- .2 Openings in required watertight bulkheads should have an efficient means of closure that will maintain the watertight integrity of the bulkhead, similar to the standards required of passenger ships as defined in SOLAS II-1/13. In all cases the number of openings in watertight bulkheads is to be kept to a minimum with respect to the design and proper operation of the yacht.
- .3 Watertight doors shall normally be closed, unless frequent access to living and working spaces through sliding watertight doors is necessary. When access to a compartment is unlikely for lengthy periods, the sliding doors or approved hinged doors shall be closed.
- .4 Electrically driven watertight doors shall have the means to be operated from an emergency source of power and each door shall be capable of being operated locally by hand.
- .5 For yachts of less than 500 GT, where it is not reasonable and practicable to meet the requirements of §4.3.1 to §4.3.3 above, hinged watertight doors in lieu of those required by SOLAS II-1/13, may be approved by the Administrator.
- .6 Where hinged watertight doors are approved, as referenced in above §4.3.5, such hinged doors shall only be provided for infrequently used openings in watertight compartments. These doors shall be fitted with audible and visual indicators in the wheelhouse and remain closed at sea, except at the Master's discretion or in accordance with operational procedures. Audible alarms may be provided with a timer delay or an "at port mode" silencer function.
- .7 Watertight doors shall be tested weekly and before each departure of the yacht. This operational test must be recorded in the appropriate logbook.
- .8 Procedures for the operation of watertight doors shall be established and posted in suitable locations.

4.4 **Enclosed Compartments Within the Hull and Below the Freeboard Deck Provided with Access through Openings in the Hull**

- .1 Compartment(s) below the freeboard deck and having access openings in the hull, shall be enclosed by watertight divisions without any opening between compartments (i.e, doors, manholes, ventilation ducts, or any other opening) unless they are provided with sliding watertight doors that are in compliance with SOLAS II-1 and that the compartment is provided with a flooding detection device with visual and audible alarms on the bridge.

- .2 For yachts of less than 500 GT, approved hinged watertight doors may be accepted, provided the following conditions are met:
 - (a) the lower edge of the shell opening shall not be below a line drawn parallel to the freeboard deck at side, which is at its lowest point at least 230 mm above the upper edge of the uppermost load line;
 - (b) a flooding detection device shall be provided in the compartment containing the shell door, with visual and audible alarms locally and on the bridge;
 - (c) the sill of the inner door is above the sill of the shell opening;
 - (d) after flooding of the space containing the shell opening, the resultant waterline is below the sill of the internal openings in that space; and
 - (e) hinged doors are to open into the shell door compartment.
- .3 Openings in the hull shall comply with SOLAS II-1/15-1. Provisions shall be made to ensure that doors may be manually closed and locked in the event of power or hydraulic failure.

4.5 Underwater Observation Spaces

- .1 Yachts that have spaces with glazed openings in the hull that are either partially or fully submerged shall:
 - (a) be enclosed by watertight divisions;
 - (b) be fitted with access via a sliding watertight door in compliance with SOLAS II-1;
 - (c) be provided with a second means of escape via watertight hatch, enabling persons to evacuate to the freeboard deck;
 - (d) be fitted in a location along the hull where excessive pressures and damage can be kept to a minimum, and shall not be along the area of the hull entrance region;
 - (e) have enhanced bilge pumping capacity no less than 150% of a standard compartment; and
 - (f) be provided with specific operational procedures in the safety management system (SMS) addressing occupation and escape of the space.
- .2 The glazed openings shall:
 - (a) along with supporting framing, have sufficient strength for the location on the yacht to the satisfaction of the RO;

- (b) utilize finite element analysis to demonstrate that the system deflections are acceptable; and
- (c) be provided with permanently attached means of watertight closure at or near the hull skin; or
- (d) if located above the turn of the bilge and where means of closure is not practical due to size and space, the Administrator may consider alternative arrangements provided they are to the satisfaction of the RO.

5.0 CONDITIONS OF ASSIGNMENT

5.1 General

- .1 All yachts shall comply with the conditions of assignment of the ILLC, as amended by this Code.
- .2 In individual cases, when the requirements of the ILLC or the Code cannot be met, the Administrator may consider alternative arrangements to achieve adequate safety standards, such as imposing operational limitations.

5.2 Hatchways and Skylight Hatches

5.2.1 General Requirements

- .1 All openings leading to spaces below the weather deck not capable of being closed weather-tight must be enclosed within either an enclosed superstructure or a weather-tight deckhouse of adequate strength.
- .2 All exposed hatchways which give access to spaces below the weather-tight weather deck are to be of substantial weather-tight construction and provided with efficient means of closure. Weather-tight hatch covers shall be permanently attached to the yacht and provided with adequate arrangements for securing the hatch closed.
- .3 Hatches that are to be used for escape purposes shall be provided with covers that are capable of being opened from both sides. An escape hatch shall be readily identifiable and easy and safe to use, having due regard to its position and access to and from the hatch.
- .4 Flush deck hatches are acceptable for escape hatches and lockers on deck, if constructed to the Rules of Class. Wells for rescue boats with flush hatches are acceptable provided they meet the Rules of Class.

5.2.2 Hatchways Open at Sea

Hatches should be kept closed at sea. However, hatchways that may be kept open for access at sea for lengthy periods are to be kept as small as is practical (a maximum of 1 square meter (m²) in a clear area), located on the centerline of the yacht, and fitted with coamings in accordance with the tables in §5.3 below. These coamings do not need to exceed 300 mm. Covers of hatchways are to be permanently attached to the hatch coamings and, where hinged, the hinges are to be located on the forward side. Alarm switches should be installed that indicate the open and close positions of the hatches in the wheelhouse.

5.3 Doorways and Companionways Located Above the Weather Deck

- .1 Exposed doors in deckhouses and superstructures that give access to spaces below the weather deck are to be weather-tight, and door openings shall have coaming heights in accordance with Table 1 below:

Table 1

Location	Category 0	Category 1 or 2
a	600 mm	300 mm
b	300 mm	150 mm
c	150 mm	75 mm

Location:

- a if the door is in the forward quarter length of the yacht and used when the yacht is at sea;
 - b if the door is in an exposed forward facing location aft of the forward quarter length; or
 - c if above the surface of the deck when the door is in a protected location aft of the forward quarter length or an unprotected door on the first-tier deck above the weather deck.
- .2 Exposed doors installed in location c per §5.3.1 may use a self-draining well in lieu of a coaming. The size of the well shall provide an equivalent level of prevention of water ingress to the satisfaction of the RO.
 - .3 Weather-tight doors shall be so arranged to open outwards and when located in the side of the house, shall be hinged at the forward edge. Alternative closing arrangements may be approved if it can be demonstrated that the efficiency of the closing arrangements and their ability to prevent the ingress of water will not impair the safety of the yacht.
 - .4 An access door leading directly to the engine room from the weather deck shall be fitted with a coaming height in accordance with Table 2 below:

Table 2

Location*	Category 0	Category 1 or 2
Position 1	600 mm	450 mm
Position 2	380 mm	200 mm

**Positions as defined as per ILLC*

- .5 Coaming heights, construction, and securing standards for weather-tight doors that are provided for use only when the yacht is in port or at anchor in calm sheltered waters and are locked closed when the yacht is at sea may be considered individually.
- .6 Companion hatch openings:
 - (a) Companionway hatch openings that give access to spaces below the weather deck shall be fitted with a coaming, the top of which is at least 300 mm above the deck. Yachts of Category 2 shall have a coaming of at least 150 mm above the deck.
 - (b) Washboards may be used to close the vertical opening. When washboards are used, they shall be so arranged and fitted that they will not be dislodged readily. Provisions are to be made to ensure that they are stowed in a secure location when not in use.
 - (c) The maximum breadth of an opening in a companion hatch shall not exceed 1 m.

5.4 Skylights

- .1 All skylights shall be of efficient weather-tight construction approved by Class. The location of the skylights shall be on or as near to the centerline of the yacht as practicable.
- .2 Skylights of the opening type shall be provided with efficient means for securing the skylight in the closed position.
- .3 A minimum of one portable cover for each size of glazed opening shall be provided which can be accessed rapidly and efficiently secured in the event of a breakage of a skylight.
- .4 Skylights that are provided as a means of escape shall be operable by hand from both sides. An escape skylight shall be readily identified and easy and safe to use, having due regard to its position and to the access to and from the skylight. Portable covers for these skylights shall be able to be opened from the inside to enable escape to the outside in case of emergency.

- .5 The skylight glazing material shall be in accordance with the requirements of glazed openings of §5.5 below.

5.5 Glazed Openings

- .1 Glazed openings shall:
- (a) be made of toughened safety glass;
 - (b) be of strength appropriate to their location in the yacht and meet the Rules of Class or a recognized national or international standard such as ISO 11336-1:2012(E);
 - (c) be substantially framed and efficiently secured to the structure;
 - (d) shall not be fitted in way of machinery spaces; and
 - (e) be of non-readily opening type.
- .2 Where glazed openings are fitted by bonding, the bonding agent(s) shall be of an approved type.
- .3 Glazed openings that are fitted:
- (a) below the freeboard deck or protect buoyant volumes shall:
 - (i) have a sill height at least 500 mm or 2.5% of the breadth of the yacht, whichever is greater, above the smallest freeboard assigned; and
 - (ii) shall be provided with a deadlight which is to be permanently attached and effectively closed and secured watertight in the event of a breakage of the glazing. Proposals to fit portable deadlights will be subject to special consideration and approval by the Administrator, having regard for the location of the glazed openings and ready availability of deadlights to be fitted.
 - (b) in the first tier front and sides of enclosed superstructures or second tier front of enclosed superstructures of a yacht of category 0 or 1; shall be:
 - (i) fitted with storm covers; or
 - (ii) where glazing thickness is increased to an equivalent strength of a storm cover, a blanking plate shall be provided for each opening size.

- .4 Regular inspections of glazing shall include, but should not be limited to:
 - (a) the surface of the glazing; and
 - (b) bonded glazed openings with respect to the bond line and any deterioration.
- .5 Where glazed openings are fitted in spaces or bulkheads that require a fire rating, the glazed openings shall meet the requirements of §[12.6](#) below.
- .6 Glazed openings in way of the conning position shall comply with the requirements of §[19.4](#) below.

5.6 Ventilators and Exhausts

- .1 Adequate natural and/or mechanical ventilation is to be provided throughout the yacht. The accommodation spaces are to be protected from the entry of gas and/or vapor fumes from galley, machinery, exhaust, and fuel systems.
- .2 Ventilators in exposed locations are to be of efficient construction and provided with permanently attached means of weather-tight closure. Ventilators serving any space below the freeboard deck or an enclosed superstructure shall have coamings of minimum heights as specified in Table 3 below:

Table 3

Location	Category 0	Category 1 or 2
Forward Quarter Length	900 mm	450 mm
Elsewhere	760 mm	380 mm

- .3 Ventilators shall be kept as far inboard as practicable and the height above the deck of the ventilator opening shall be sufficient to prevent the ingress of water when the yacht heels.
- .4 The ventilation of spaces, such as the machinery space, that must remain open require special attention with regard to the location and height of the ventilation openings above the deck taking into account the effect of down-flooding angle on stability standard.
- .5 The means of closure of ventilators serving the machinery space shall be selected with regard to the fire protection and extinguishing arrangements provided in the machinery space.
- .6 Engine exhaust outlets that penetrate the hull below the freeboard deck shall be provided with means to prevent back-flooding into the hull through a damaged exhaust system. Yachts of Category 0 shall have a means of positive closure where the outboard side is of an equivalent construction to the hull. Where it is not practicable for yachts of Category 1 and 2 to comply with the above

requirements of positive closure, well-constructed anti-siphon loops shall be installed on all exhaust lines at a minimum of 1 m above the waterline or a satisfactory waterbreak system.

5.7 Air Pipes

- .1 Air pipes serving fuel and other tanks shall be of efficient construction and provided with permanently attached means of weather-tight closure. Means of closure may be omitted if it can be shown that the open end of an air pipe is protected by other structures that will prevent the ingress of water.
- .2 Where located on the weather deck, air pipes shall be kept as far inboard as practicable and be fitted with a coaming of sufficient height to prevent inadvertent flooding. Where this is impractical to do so, air pipes may be fitted in a suitable protected area elsewhere, provided that this location is to the satisfaction of the RO. Air pipes to tanks should have coamings of minimum heights as specified in Table 4 below:

Table 4

Location	Category 0	Category 1 or 2
On Weather Deck	760 mm	380 mm
Elsewhere	450 mm	225 mm

- .3 Air pipes to fuel tanks shall terminate at a height of not less than 760 mm above either the top of the filler pipe for a gravity filling tank or the top of the overflow tank for a pressure filling tank.

5.8 Scuppers, Sea Inlets, and Discharges

The standards of the ILLC shall be applied to every discharge led through the shell of the yacht. All sea inlet and overboard discharges shall be provided with efficient shut-off valves arranged in positions where they are readily accessible at all times.

5.9 Materials for Valves and Associated Piping

- .1 Valves that are fitted below the waterline shall be of steel, bronze, or other material having a similar resistance to impact and fire.
- .2 The associated piping shall, in areas as indicated above, be of steel, bronze, copper, or other equivalent material that is considered of equal or greater strength than the hull.
- .3 Where the use of plastic piping is proposed, it will be considered on an individual basis and full details of the type of piping and its intended location and use shall be submitted to the Administrator for consideration. The Administrator may

require tests to be carried out on the plastic piping, as necessary, before approving its use.

- .4 The use of flexible piping in any situation should be kept to a minimum, compatible with the essential reason for its use. The RO shall approve flexible piping and the means of joining it to its associated hard piping system as fit for the purpose.

5.10 Underwater Lights

Underwater lights and their installation shall be approved by the RO.

5.11 Water Freeing Arrangements

- .1 For all yachts, the standards for water freeing arrangements shall comply with the ILLC. In individual cases where the requirements of the ILLC cannot be met, the Administrator may consider alternative arrangements to achieve adequate safety standards, such as, operational limitations. In any case, the intention should be to achieve a standard of safety that is at least equivalent to the standard of the ILLC.
- .2 When a yacht is unable to fully comply with the ILLC, the Administrator may take into account the yacht's past performance in service and the declared area(s) of operation and assign a limited range Category 1 or 2. This notation will be recorded on the CYCC, as applicable.
- .3 Recesses on a yacht:
 - (a) any recess in the weather deck shall be of weather-tight construction and shall be self-draining under all normal conditions of heel and trim of the yacht;
 - (b) an open swimming pool or spa shall be treated as a recess;
 - (c) the recess drainage arrangement shall be capable of efficient operation when the yacht is heeled at an angle of 10 degrees (°) for a motor yacht and 30° for a sailing yacht;
 - (d) the drainage arrangement shall be such as to be able to empty the full recess within three minutes when a yacht is in a normal seagoing condition and to prevent the backflow of water into the recess; and
 - (e) any alternative arrangements proposed for consideration by the Administrator should take into account the mass of water and its free surface effect on the intact and damage stability.

5.12 **Bulwarks and Guard Rails**

Yachts shall comply with the ILLC requirements, unless compliance is unreasonable or not practicable.

- .1 Where there will be people on the deck frequently, bulwarks or three courses of rail or taut wires shall be fitted around the deck at a height of not less than 1 m from the deck. Guard rails or taut wires when used shall be supported by stanchions at intervals not exceeding 2.2 m. Intermediate courses of rails or wires shall be evenly spaced.
- .2 Where the function of the yacht would be impeded by the provision of bulwarks and/or guard rails complying with §5.12 above, alternative proposals detailed to provide an equivalent level of safety for persons on deck may be submitted to the Administrator for review and approval.
- .3 Glazed bulwarks may be used provided they are constructed and installed to the satisfaction of the RO or to a recognized national or international standard.

5.13 **General Equivalence**

Where yachts cannot comply with the requirements of §5.1 to §5.12 above, equivalent arrangements may be considered by the Administrator. Such proposals shall take into account the following non-exhaustive list:

- (a) closure at sea;
- (b) enhanced bilge pumping capacity and bilge alarms;
- (c) full compliance with damage stability;
- (d) provision of dorade boxes or baffle systems to prevent direct water ingress;
- (e) alternative ventilation for use in bad weather;
- (f) excess freeboard – greater than one standard superstructure height;
- (g) consideration of risk of down-flooding angle and height due to position;
- (h) consideration of risk of green sea loads;
- (i) enhanced survey inspection regime; and
- (j) operational limitations.

6.0 FREEBOARD

6.1 General

- .1 Compliance with the ILLC is mandatory for all yachts of 24 m or more in length.
- .2 For existing yachts where full compliance with the ILLC cannot be attained, the Administrator may consider exemptions in accordance with Article 4 of the ILLC.
- .3 The freeboard of the yacht and its markings shall be approved by the RO for the assignment of freeboard and the issuance of the International Load Line Certificate.
- .4 Yachts shall comply with the ILLC for the assignment of a greater than minimum freeboard mark which corresponds to the deepest loading condition included in the stability information booklet for the yacht.
- .5 The assigned freeboard shall reflect damage as well as intact stability, geometry, hull structure, and fittings. The assigned freeboard shall ensure compliance with minimum bow height and reserve buoyancy.
- .6 Yachts of novel design and yachts which, to suit exceptional operational requirements, cannot meet the bow height requirements may be given special consideration by the Administrator.
- .7 The RO issuing the ILLC Certificate shall provide the yacht with a copy of the particulars of the freeboard assigned and a copy of the record of conditions of assignment, which is required to be kept on board at all times.

6.2 Freeboard Mark and Loading

- .1 The freeboard mark applied may be an all seasons mark positioned port and starboard at amidships of the length.
- .2 The fresh water freeboard allowance shall be obtained by deducting from the all seasons freeboard assigned:

$$\Delta/4T \text{ mm}$$

Where:

Δ = displacement in salt water in tons at the all seasons load waterline; and

T = tons per centimeter (cm) immersion in salt water at the all seasons load waterline.

Alternatively, the deduction may be taken as $1/48^{\text{th}}$ of the all seasons draft of the yacht at amidships.

- .3 Marking of the fresh water allowance is optional.
- .4 A yacht shall not operate in any condition that will result in its appropriate freeboard marks being submerged when it is at rest and upright in calm water.

6.3 Draft and Load Line Marks

6.3.1 Draft Marks

- .1 Draft marks shall be provided at the bow and stem, port and starboard, and be adequate in number for assessing the condition and trim of the yacht. A draft mark may be a single datum line.
- .2 Draft marks shall be permanent and easily read but need not be of contrasting color to the hull. The marks need not be at more than one draft at each position but shall be above and within 1,000 mm of the deepest load waterline. The paint line of the boot topping may be used if this has permanent marks indented in the hull.
- .3 The draft to which marks relate shall be indicated either above the mark on the hull and/or in a record on the docking plan or stability information for the yacht.

6.3.2 Load Line Marks

- .1 The load line or Plimsoll mark shall be permanent and easily seen by raising the mark or using a contrasting color to the hull in way of the mark and dimensionally consistent with requirements of the ILLC. The center of the ring shall be placed amidships and at a distance equal to the assigned summer freeboard measured vertically below the upper edge of the deck line.
- .2 The summer load line is indicated by the upper edge of the line which passes through the center of the ring.
- .3 For classed yachts, the mark of the authority by whom the load lines are assigned may be indicated alongside the load line ring above the horizontal line which passes through the center of the ring, or above and below it. This mark shall consist of not more than four initials to identify the authority's name, each measuring approximately 115 mm in height and 75 mm in width.
- .4 For unclassified yachts carrying a Plimsoll mark, the marking used shall be "MI."
- .5 The ring, lines, and letters shall be of a permanent form and be of contrasting color to the hull in way of the marks.

6.4 Docking Plan

The yacht shall be provided with a docking plan, a copy of which shall be maintained on board.

7.0 STABILITY – INTACT AND DAMAGED

7.1 General

- .1 The standards set forth in this section shall be met for both intact and damaged stability.
- .2 An intact stability standard proposed for assessment of a yacht configuration, which is not covered by this Code, shall be submitted to the RO for review at the earliest opportunity.
- .3 Permanent ballast used onboard a yacht shall be located and installed to the requirements of the RO. Permanent ballast shall be installed as such that prevents shifting of position and shall not be removed from the yacht or relocated within the yacht without the approval of the RO. Permanent ballast particulars shall be noted in the stability booklet. Local or global hull strength requirements for the installation of additional ballast shall be assessed.

7.2 Intact Stability

7.2.1 All Motor Yachts

The statical stability curves for seagoing conditions shall meet the following criteria:

- (a) the area under the righting lever (GZ) curve shall not be less than 0.055 meter-radians up to $\phi=30^\circ$ angle of heel and not less than 0.09 meter-radians up to $\phi=40^\circ$ angle of heel, or the angle of down-flooding ϕ_f^5 , if this angle is less than 40° ; additionally, the area under the GZ curve between the angles of heel of 30° and 40° or between 30° and the angle of down-flooding ϕ_f , if this angle is less than 40° , shall not be less than 0.03 meter-radians;
- (b) the GZ shall be at least 0.20 m at an angle of heel equal to or greater than 30° ;
- (c) the maximum GZ shall occur at an angle of heel not less than 25° ;
- (d) after correction for free surface effects, the initial metacentric height (GM) shall not be less than 0.15 m; and
- (e) for Category 2 yachts, in the event that the intact stability standard fails to comply with the criteria defined in §7.2.1a to §7.2.1d above, the equivalent stability standards of §7.2.2 below may be considered by the Administrator as recommended by the RO.

⁵ ϕ_f is an angle of heel which openings in the hull, superstructures, or deck-houses which cannot be closed weather-tight immerse. In applying this criterion, small openings through which progressive flooding cannot take place need not be considered as open.

7.2.2 Equivalent Stability Standards

Where Category 2 motor yachts are unable to meet the criteria in §7.2.1 above, the following criteria may be used:

- (a) the area under the GZ curve shall not be less than 0.07 meter-radians up to 15° angle of heel, when maximum GZ occurs at 15°, and 0.055 meter-radians up to 30° angle of heel, when maximum GZ occurs at 30° or above. Where the maximum GZ occurs at angles of between 15° and 30°, the corresponding area under the GZ curve shall be:

$$0.055 + 0.001(30^\circ - \varphi_{\max}) \text{ meter-radians;}^6$$

- (b) the area under the GZ curve between the angles of heel of 30° and 40°, or between 30° and the angle of down-flooding (φ_f) if this is less than 40°, shall not be less than 0.03 meter-radians;
- (c) the GZ shall be at least 0.20 m at an angle of heel equal to or greater than 30°;
- (d) the maximum GZ shall occur at an angle of heel not less than 15°; and
- (e) after correction for free surface effects, the GM shall not be less than 0.15 m.

7.2.3 High Speed Yachts

Yachts capable of attaining higher speeds or planing shall also take into consideration the characteristics of these hull forms, including but not limited to directional instability, bow diving, reduction of transverse stability, porpoising, and chine tripping.

7.2.4 Sailing Yachts

Sailing yacht stability shall be considered on a case-by-case basis by the RO.

7.3 Damage Stability

- .1 Damage stability shall be applied to all yachts as an equivalency for non-compliance with full ILLC Conditions of Assignment.
- .2 Damage stability is not applicable to:
 - (a) yachts that obtain full compliance with the ILLC Conditions of Assignment; and
 - (b) yachts less than 500 GT and limited to Category 2 on the basis that the freeboard is greater than the required minimum and the yacht's restricted

⁶ φ_{\max} is the angle of heel in degrees at which the GZ curve reaches its maximum.

service. It is recommended that the requirements of §7.3.3 through §7.3.6 are met where practicable.

- .3 The watertight bulkheads of the yacht shall be so arranged that minor hull damage that results in the free flooding of any one compartment will cause the yacht to float at a waterline which, at any point, is not less than 75 mm below the weather deck, freeboard deck, or bulkhead deck, if not concurrent.
- .4 Minor damage shall be assumed to occur anywhere in the length of the yacht, but not on a watertight bulkhead (transverse or longitudinal).
- .5 Standard permeabilities shall be used in this assessment, as follows in Table 5 below:

Table 5

Space	Percentage Permeability
Stores	60
Stores but not a substantial quantity thereof	95
Accommodation	95
Machinery	85
Liquids	95 or 0 whichever results in the more onerous requirements

- .6 In the damaged condition, the residual stability shall be such that any angle of equilibrium does not exceed 7° from the upright, the resulting GZ curve has a range to the down-flooding angle of at least 15° beyond any angle of equilibrium, the maximum GZ within that range is not less than 100 mm and the area under the GZ curve is not less than 0.015 meter-radians.

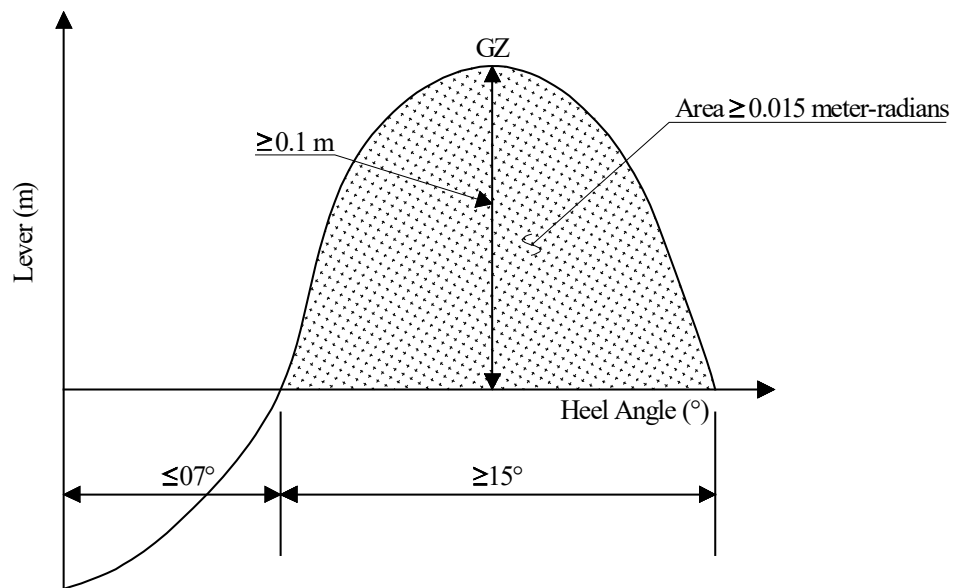

- .7 A yacht of 80 m in length and above shall meet a SOLAS one-compartment standard of subdivision calculated using the deterministic damaged stability methodology.

7.4 Elements of Stability

- .1 The lightship displacement, vertical center of gravity (KG), and longitudinal center of gravity of a yacht shall be determined from the results of an inclining experiment.
- .2 An inclining experiment shall be conducted in accordance with a detailed standard as well as a specific test procedure that is approved by the RO. In addition, the experiment shall be conducted in the presence of the RO.
- .3 The report of the inclining experiment and the lightship particulars derived shall be approved by the RO.
- .4 At the discretion of the owner(s) or managing agent(s), and prior to approval of the lightship particulars by the RO, a margin for safety may be applied to the lightship displacement and KG calculated after the inclining experiment.
- .5 Such a margin shall be clearly identified and recorded in the stability booklet.
- .6 A formal record shall be kept in the stability booklet of alterations or modifications to the yacht which affect lightship displacement, KGs, and/or longitudinal center of gravity (LCG).
- .7 When sister yachts are built at the same shipyard, the RO may accept lightweight check on subsequent yachts to corroborate the results of the inclining experiment conducted on the lead yacht of the class.

7.5 Stability Documents

- .1 All yachts shall be provided with a stability booklet for the Master that is approved by the RO, which contains sufficient information to enable the Master to operate the yacht in compliance with the applicable requirements contained in the Code.
- .2 The stability booklet shall take into account the additional guidelines in accordance with the IS Code Part B, Chapter 3, Sections:
 - (a) 3.1 – Effect of free surfaces of liquid in tanks;
 - (b) 3.2 – Permanent ballast;
 - (c) 3.3 – Assessment of compliance with stability criteria;

- (d) 3.4 – Standard conditions of loading to be examined;
 - (e) 3.5 – Calculation of stability curves; and
 - (f) 3.6 – Stability booklet.
- .3 Sailing yachts shall have a copy of the *Curves of Maximum Steady Heel Angle to Prevent Downflooding in Squalls* placed in a suitable position for the ready reference of the crew. This shall be a direct copy taken from that contained in the approved stability booklet.
- .4 For yachts where the damage stability has not been assessed, the following note shall be added to the approved stability booklet:
- “This yacht has not been assessed for damage stability, and therefore might not remain afloat in the event of damage or flooding.”*
- .5 Yachts of 500 GT and above shall carry damage control information as required per SOLAS II-1/19 consisting of:
- (a) an approved Damage Control Plan which must be permanently exhibited or readily available in the wheelhouse; and
 - (b) approved Damage Control Booklets which are made available to the officers performing the watch. The Stability Booklet, as referred to in §7.5.1 above, may contain the Damage Control Booklet, but this must be in a separate section, easily distinguished from the stability information. See *Intact Stability, Damage Stability, and Strength of Vessels* ([MN 2-015-1](#)), §1.0.

7.6 Major Refit or Alterations

- .1 A yacht with previously approved stability information, which undergoes a major refit or major alterations, shall be subjected to re-inclining, in accordance with §7.4 above, and a reassessment of the stability booklet.
- .2 Changes in a yacht’s buoyancy (such as a stern extension) which results in a calculated change in displaced volume of more than 2%, shall require a complete reassessment of stability and newly approved stability information booklets.
- .3 Reconfiguration of the tank arrangement shall require a revision of the yacht’s stability booklet.

- .4 A lightweight survey shall be carried out at an interval not exceeding five years, unless it can be clearly demonstrated that no major change has occurred.
- .5 Notwithstanding §7.6.4 above, a yacht shall undergo a lightweight survey every 10 years.
- .6 The yacht shall be re-inclined whenever, in comparison with the approved stability information, a deviation from the lightship displacement exceeding 2% or a deviation of the lightship LCG exceeding 1% is found or anticipated.

8.0 SAILING YACHT RIGGING

8.1 General

- .1 The condition of the rigging shall be monitored in accordance with a planned maintenance manual and schedule, approved by the RO. The schedule shall include, in particular, regular monitoring of all the gear associated with safe work aloft and on the bowsprit (see §[27.1](#)).
- .2 The overall sail area and spar weights and dimensions shall be documented in the stability information book. Modifications that increase sail area and/or weights and dimensions must be reflected in an approved updating of the stability information booklet.
- .3 All equipment items used for standing rigging, including loose items of gear such as shackles, bottle screws, sheaves, etc. are to be tested and periodically surveyed by a Classification Society that has rules for such equipment.

8.2 Masts and Spars

- .1 Dimensions and materials of the masts and spars shall be certified as being in accordance with the rules or recommendations of a Classification Society or an internationally recognized standard.
- .2 The associated structure for masts and spars (including fittings, decks, and floors) shall be certified as being constructed as to absorb the forces involved.

8.3 Running and Standing Rigging

Running and standing rigging shall meet the following requirements:

- (a) wire rope used for standing rigging (stays or shrouds) is not to be flexible wire rope (fiber rope core);

- (b) the strength of all blocks, shackles, rigging screws, cleats and associated fittings, and attachment points shall exceed the breaking strength of the associated running or standing rigging; and
- (c) chainplates for standing rigging shall be constructed to support and absorb the forces involved. Only one shroud or stay should load an individual attachment point, unless the approved design specifically allows for more.

8.4 Sails

- .1 Adequate means of reefing or shortening sail shall be provided.
- .2 Category 0 and Category 1 yachts shall either be provided with separate storm sails or have specific sails designated and constructed to act as storm canvas.

9.0 ACCOMMODATIONS

9.1 General

Sections [9.4](#) to [9.23](#) describe the minimum standards of accommodations, recreational facilities, food, and catering for new and existing yachts as defined in §9.2 and §9.3.

9.2 New Yachts

The Administrator acknowledges that, due to the size and operational limitations, certain yachts built after the date of entry into force of the MLC, 2006 (“new yachts”) cannot always fully comply with Title 3 of the MLC, 2006. In such cases, a substantially equivalent arrangement shall be submitted to the Administrator by the certifying RO.

For further guidance on the MLC, 2006 certification, refer to [§1.13](#) of this Chapter.

9.3 Existing Yachts

For yachts constructed before the date of entry into force of MLC, 2006 (“existing yachts”):

- (a) Seafarer accommodations on board a yacht should, to the extent reasonable and practicable, comply with the applicable standards set by the ILO conventions and any other international convention to which the RMI is a signatory and shall comply with the applicable requirements of the RMI Maritime Regulations ([MI-108](#)) and the RMI Maritime Act ([MI-107](#)). The applicable international conventions which have been adopted by the RMI are referenced in *International Maritime Conventions and Other Instruments Adopted by the Republic of the Marshall Islands* ([MN 2-011-1](#)).

- (b) The Administrator acknowledges that existing yachts may find it very difficult to comply with Title III of ILO Convention No. 92 and Title II of ILO Convention No. 133 in their entirety. In lieu of having to fully comply, the following are areas considered to be subject to the establishment of substantial equivalencies:
- (i) Each owner shall meet, provide, and maintain minimum standards for safe, decent, and comfortable living accommodations, recreational facilities, food, catering, and water for seafarers which are required to work or live on board, or both, consistent with promoting the seafarer's health and well-being.
 - (ii) Attention is to be drawn to the achievement of appropriate standards for means of access and escape, lighting, heating, food preparation and storage, safety of movement about the yacht, ventilation, and water services.
 - (iii) For smaller yachts, in particular sailing yachts and motor yachts of less than 200 GT, the standards found in this §9.0 shall be applied as far as is reasonable and practicable to do so and to the satisfaction of the Administrator.
 - (iv) The crew accommodation shall not be located below the deepest waterline or within hazardous spaces and in no case forward of the collision bulkhead. Where it is not possible to locate the accommodation above the deepest waterline, an audible and visual flooding alarm shall be installed to alert persons and provide them with sufficient time to evacuate the accommodation.

9.4 Headroom and Ceiling Heights

- .1 Adequate headroom shall be provided for all seafarers on board, taking the size and operation of the yacht into consideration.
- .2 In areas where a crewmember is expected to stand for a prolonged period of time, the headroom shall be not less than 190 cm. The Administrator may approve reduced heights in certain locations as long as this does not result in discomfort to the crewmember and will not cause a seafarer to inadvertently come in contact with the ceiling or appurtenances thereto during their normal course of work.

9.5 Hand Holds and Grab Rails

There shall be sufficient hand holds and grab rails within the accommodation to allow safe movement around the accommodation at all times.

9.6 Access/Escape Arrangements

See §[11.4](#) below for yachts less than 500 GT and §[12.13](#) below for yachts of 500 GT or more, as applicable.

9.7 Lighting

- .1 An electric lighting system shall be installed which is capable of supplying adequate light to all enclosed accommodation and working spaces. The system shall be designed and installed in accordance with §[13.5](#) and §[14.4](#) of this Chapter, as applicable.
- .2 Sleeping rooms and mess rooms shall be lit by natural light, as far as is reasonable and practicable, and additionally provided with adequate artificial light.

9.8 Heating and Insulation

- .1 Where appropriate, an adequate heating installation shall be provided in all accommodation spaces.
- .2 External bulkheads of crew accommodation spaces shall be adequately insulated taking all climatic conditions into account. All machinery casings and all boundary bulkheads of galleys and other spaces in which heat is produced shall be adequately insulated where there is a possibility of resulting heat effects in adjoining accommodation or passageways. Measures shall also be taken to provide protection from heat effects of steam or hot-water service pipes, or both.
- .3 Radiators or other external heating apparatus shall be shielded so as to avoid risk of fire or danger or discomfort to the occupants.

9.9 Noise and Vibration

Please reference §[27.3](#) of this Chapter.

9.10 Food Preparation and Storage Facilities

- .1 The galley shall be provided with a cooking stove fitted with fiddle bars and a sink and shall have adequate working surface for the preparation of food.
- .2 The galley floor shall be provided with a non-slip surface and provide a good foothold.
- .3 When a cooking appliance is gimballed, a crash bar or other means to prevent personal injury shall protect it. Means shall be provided to lock the gimbal mechanism.

- .4 Means shall be provided to allow the cook to work safely in a steadied position, with both hands free for working, when a yacht's motion threatens safe working.
- .5 Galley furniture and fittings shall be, as far as is reasonable and practicable, made of rust resistant material which is impervious to dirt and moisture.
- .6 Secure and hygienic storage for food shall be provided.
- .7 The galley ventilation shall be adequate to supply fresh air and efficient discharge of fumes into the open air. Galley hood filters shall be kept free from oil and grease.
- .8 Separate storage for garbage that is intended to be disposed of ashore or otherwise shall be provided and such storage shall not be within the seafarer accommodation. Garbage shall be stored in a manner which avoids health and safety hazards, such as in sealed containers or bags.
- .9 One single common mess room for seafarers who are officers and other seafarers is acceptable.
- .10 Mess rooms shall be provided and equipped with tables and appropriate seats, fixed or movable, sufficient to accommodate the greatest number of seafarers likely to use them at any one time.
- .11 For yachts of less than 200 GT, the mess room may be a shared facility for seafarers and passengers.
- .12 When seafarers are on board, the following shall be available at all times:
 - (a) a refrigerator, which shall be conveniently situated and of sufficient capacity for the number of persons using the mess room(s);
 - (b) facilities for hot beverages; and
 - (c) cool potable water facilities.

9.11 Water Services

- .1 An adequate supply of fresh filtered drinking water shall be provided and piped to convenient positions throughout the accommodation spaces, especially the galley.
- .2 In addition, an emergency reserve supply of drinking water shall be carried, sufficient to provide at least 2 liters (L) per person.

- .3 Fresh water systems (including fresh water tanks and reception facilities) shall be of an approved marine type and maintained in a clean condition to protect contamination of the water.
- .4 If a yacht cannot produce its own water supply, sterilization by ultraviolet (UV) is not acceptable on its own, but may be accepted as a secondary means. Disinfection arrangements are to be accepted by the Administrator (for this purpose silver ionization or chlorination would be considered acceptable).
- .5 Any equipment for the production and filtering of fresh water shall be maintained in accordance with the manufacturer's instructions. It is recommended that a maintenance log be kept and maintained that includes any service or repairs carried out.

9.12 Sleeping Accommodation

- .1 Yachts of 3,000 GT or more constructed on or after 20 August 2013 shall comply with the full requirements of standard A3.1 of the MLC, 2006.
- .2 Yachts up to but less than 3,000 GT:
 - (a) The Master, the Chief Engineer, and the Chief Navigating Officer should have cabins that, in addition to their sleeping rooms, include an adjoining sitting room, day room, or equivalent additional space. Where this is not practicable, an alternative comfortable shared sitting area may be provided. Such space shall allow officers to meet privately with other seafarers.
 - (b) Single berth cabins for seafarers who are officers where an adjoining sitting room, day room, or equivalent additional space to the sleeping room is provided, the sleeping room shall not be less than 4.5 m² including en-suite sanitary facilities.
 - (c) Single berth cabins for seafarers who are officers where no adjoining sitting room, day room, or equivalent additional space are provided shall not be less than 7.5 m² including en-suite sanitary facilities.
 - (d) Seafarers who are officers should not be required to share a cabin.
 - (e) To the extent possible, an individual cabin shall be provided for each seafarer who is not an officer, the floor area of which shall not be less than 4.5 m² which may include en-suite sanitary facilities.
 - (f) Where it is not practicable to provide single occupancy cabins, sleeping rooms may be occupied by two seafarers who are not officers. The floor area shall not be less than 7.0 m² which may include en-suite sanitary facilities.

- .3 Yachts of less than 1,250 GT:
- (a) Single berth cabins for seafarers who are not officers without en-suite sanitary facilities shall have a floor area of not less than 3.6 m².
 - (b) Single berth cabins provided with en-suite facilities for seafarers who are not officers, shall have a floor area of not less than 4.5 m² including the sanitary module.
 - (c) Double berth cabins without en-suite facilities for seafarers who are not officers shall have a floor area of not less than 7 m².
 - (d) Double berth cabins for seafarers who are not officers, where en-suite sanitary facilities are provided, shall have a minimum floor area of not less than:
 - (i) 6.2 m² for a yacht of 500 GT to 1,149 GT; and
 - (ii) 7 m² for a yacht of 1,150 GT and over, including the sanitary module.
 - (e) En-suite sanitary facilities are considered to compensate for reduced floor area and form part of the floor area.
 - (f) Where the reduced floor areas in §9.12.3a to §9.12.3d above are adopted, the free floor area in the cabin shall be at least 1.45 m² per seafarer.
 - (g) Where the requirement of §9.12.3f above is not practical due to the hull shape or hull stiffening, but the arrangements in the cabin allow for a free movement of the upper part of the body equivalent to an area of 1.45 m², a reduced free floor area may be provided with the Administrator's agreement, but shall not be less than 1 m² per seafarer.
- .4 Sleeping accommodations shall be situated and/or equipped as to provide appropriate levels of privacy for men and women.
- .5 There shall be no access into sleeping rooms from spaces for machinery, galleys, paint rooms, or any store rooms and communal wash, shower, or toilet facilities. Bulkheads separating such places from sleeping rooms shall be efficiently constructed of steel or equivalent material and be watertight and gas-tight.
- .6 A berth shall be provided for every seafarer on board, which has at least one unobstructed access. Where considered appropriate, means for preventing the occupants from falling out shall be provided.

- .7 The minimum inside dimensions of a berth shall be either:
 - (a) not less than 190 cm by 70 cm, without tapering; or
 - (b) at least 198 cm by 80 cm where tapering may be permitted when half of the length of the berth is not narrower than 50 cm.
- .8 When one berth is placed over another, a dust-proof bottom shall be fitted beneath the bottom mattress or spring bottom of the upper berth.
- .9 Each berth shall be fitted with a comfortable mattress with a cushioning bottom. The mattress and cushioning material used shall be made of approved material.
- .10 Sleeping rooms shall be fitted with curtains or equivalent for the sidelights.
- .11 In sleeping rooms, a shielded electric reading lamp shall be installed at the head of each berth.
- .12 Each sleeping room shall be provided with a table or desk, which may be of the fixed, drop-leaf or slide-out type, and with comfortable seating accommodation.

9.13 Stowage Facilities for Personal Effects

- .1 Every seafarer is to be provided with a clothes locker of ample space (minimum 475 L and a drawer or equivalent space of not less than 56 L). If the drawer is incorporated in the clothes locker then the combined minimum volume of the clothes locker shall be 500 L. The locker shall be fitted with a shelf and be able to be locked by the seafarer so as to ensure security and maintain privacy. Where the total required volume cannot be provided within the cabin, the Administrator may consider accepting secure facilities for the individual elsewhere within the seafarer accommodation, provided that within the cabin a minimum of 300 L storage space is provided for each individual seafarer.
- .2 For yachts less than 200 GT, storage facilities must be a minimum of 125 L per seafarer.

9.14 Sanitary Facilities

- .1 Adequate sanitary toilet facilities shall be provided. The facilities shall be provided with a lockable door and at least one water closet, one sink (hand wash basin) and one shower for every four persons or part thereof.
- .2 For yachts of less than 200 GT, the sanitary toilet facilities as referenced in §9.14.1 may be increased to six persons or part thereof.
- .3 Hot and cold running fresh water shall be available in all wash places.

- .4 Separate sanitary facilities shall be provided for men and women, where it is reasonable and practicable to do so.
- .5 Where a sanitary system, including a holding tank, is provided, care shall be taken to ensure that there is no possibility of fumes from the tank finding their way back to a toilet, should the water seal at the toilet be broken.
- .6 En-suite sanitary facilities are considered to compensate for reduced floor area and form part of the floor area. The en-suite sanitary facilities should be large enough to allow for the facilities to be used with the door closed and would not be expected to have a floor area of less than 1.2 m². Where the floor area of the en-suite sanitary facilities provided is greater than 1.2 m², the free floor area of the cabin may be reduced accordingly, but shall never be less than 1 m² per seafarer.

9.15 Recreational Facilities

- .1 Seafarers shall be provided with appropriate recreational facilities, amenities, and services.
- .2 Safe space(s) on open deck shall be provided to which the seafarers can have access when off duty, which are of adequate area having regard to the size of the yacht and the number of seafarers on board.

9.16 Laundry Facilities

- .1 For yachts of 500 GT and above, appropriate laundry facilities shall be available.
- .2 The laundry facilities provided for seafarer use shall include:
 - (a) washing machines supplied with hot and cold fresh water;
 - (b) drying machines or adequately heated and ventilated drying rooms; and
 - (c) irons and ironing boards or their equivalent.

9.17 Office Space

All yachts of 500 GT and above shall be provided with separate offices or a common ship's office for use by deck and engine departments. The Administrator may consider an alternative equivalent arrangement.

9.18 **Diversity**

In accordance with Title 3, Regulation 3.1 of the MLC, 2006, in the case of yachts where there is need to take into account the interests of seafarers having differing and distinctive religious and/or social practices, fairly applied variations in respect of these standards may be permitted on the condition that such variations do not result in overall facilities less favorable than those which would result from the application of these minimum standards.

9.19 **Onboard Inspections**

- .1 Weekly inspections shall be carried out on board by, or under the authority of, the Master to ensure that crew accommodations are clean, decently habitable, and maintained in a good state of repair.
- .2 These inspections shall also be carried out, with respect to:
 - (a) the sufficiency of supplies of food and potable drinking water;
 - (b) the sufficiency and cleanliness of all spaces and equipment used for the storage and handling of food and potable drinking water; and
 - (c) the sufficiency and cleanliness of the galley and other equipment for the preparation and service of meals.
- .3 The date and results of each such inspection shall be recorded in the Master's official logbook and be available for review.

9.20 **Mosquito Protection**

Yachts regularly trading to mosquito-infested ports shall be fitted with appropriate devices.⁷

9.21 **Securing of Heavy Equipment**

- .1 Appropriate provisions shall be provided to allow the securing of all heavy items of equipment such as ballast, batteries, cooking stove, etc.
- .2 All stowage lockers containing heavy items shall have lids or doors that are capable of being securely fastened.

⁷ The World Health Organization provides the International Health Regulations and Guide to Ship Sanitation within which are guidelines to be taken into account when designing and constructing the yacht in order to control insects. These guidelines are also relevant to the sleeping quarters, mess rooms, and dining rooms, indoor recreational areas, as well as all food spaces, where yachts are in transit in areas where flies and mosquitoes are prevalent. Control measures that may be employed by the Master and crew are also provided in these guidelines.

9.22 Hospital Facilities

- .1 Yachts of 500 GT and above and carrying 15 or more seafarers and engaged in a voyage of more than three days duration shall provide separate hospital accommodation to be used exclusively for medical purposes.
- .2 The hospital accommodation shall be designed to facilitate consultation and the giving of medical first aid and to help prevent the spread of infectious diseases.
- .3 The arrangement of the entrance, berths, lighting, ventilation, heating, and water supply shall be designed to ensure the comfort and to facilitate the treatment of the occupants.
- .4 Sanitary accommodations shall be provided for the exclusive use of the occupants of the hospital accommodation, either as part of the accommodation or in close proximity thereto. Such sanitary accommodation comprises a minimum of one water closet, one sink (hand wash basin), and one shower.
- .5 The Administrator may amend or waive the requirements of this §9.22 for yachts of Category 1 or 2, as appropriate.
- .6 Equivalent arrangements for the hospital accommodation shall be considered by the Administrator on a case-by-case basis.

9.23 Elevators (Lifts), Escalators, and Other Accommodation Lifting Devices

- .1 Lifting devices shall be designed and constructed to recognized international standards.
- .2 Elevators shall be provided with:
 - (a) suitable means of escape from the car and shaft; and
 - (b) emergency power and emergency lighting in the shaft and car; and
 - (c) means of alarm that shall provide an audible and visual alarm in the crew area and bridge; or
 - (d) means of fixed communication with the bridge and any other emergency control station(s); and
 - (e) a clear marking or sign that the elevator is not to be used in case of emergency.

- .3 Before a lifting device is put into service, it must be tested and examined with regard to load and functions by a competent person and a certificate issued to the yacht. The term "competent person" is as defined in the ILO Convention No. 152.
- .4 Regular in service examination as required by the manufacturer shall be carried out by a manufacturer certified person.

10.0 FIRE SAFETY AND PREVENTION

10.1 Stowage of Gasoline, Aviation Fuel, and Other Highly Flammable Liquids

The following apply to ensure for the safe stowage of gasoline, aviation fuel, and other highly flammable liquids having a flash point of less than 60° Celsius (C) (herein referred to as "flammable liquids") that may be carried in portable container(s), permanently fitted tank(s), or other methods.

10.1.1 Portable Containers Including Portable Tanks

- .1 Portable containers shall not be stored at a location which is exposed to the environment. Weather conditions, sea state, wind force, etc., are to be taken into consideration.
- .2 Portable containers shall be kept to a minimum, containing no more than 150 L of flammable liquids in total. Means of carriage to consider for portable containers or tanks may be:
 - (a) recessed stowage with overboard chutes;
 - (b) lockers on deck, fully ventilated and with a fixed fire suppression system;
or
 - (c) internal lockers with a fixed fire suppression system.

Such locations shall be clearly marked to identify that flammable liquids are contained within.

- .3 Portable containers used for the carriage of flammable liquids shall be constructed to a recognized standard that is appropriate to the type of flammable liquid to be carried. Additionally, each container shall be clearly marked to indicate its contents.

10.1.2 Permanent Tanks

- .1 Yachts fitted with storage tanks for aviation fuel shall comply with the requirements of the *Rules of The Civil Aviation Authority's Standards for Offshore Helicopter Landing Areas* (CAP 437) Chapter 7 and in accordance with the Rules of Class.
- .2 Yachts fitted with permanent tanks for the carriage of flammable liquids, other than in §10.1.2.1 above, shall comply to the below requirements in §10.1.2.3 through §10.1.2.16 below.
- .3 The design, construction and material of the permanent installed tank shall comply to the Rules of a Classification Society.
- .4 Tanks shall be explosion protected, ventilate to a safe environment, and prevent the risk of overpressure and fire/explosion. A vapor recovery system shall be considered.
- .5 High level alarm systems to warn the crew for overfilling of the tank(s) and means of remote tank level monitoring shall be provided. The remote measuring must be capable of monitoring outside the tank space. Gauge glasses are not permitted.
- .6 Tanks shall be located in a purposely built gas tight compartment. This space shall only be used for the installation of the storage tank(s) and associated equipment for fuel transfer to and from the tank. Permanently fixed tanks shall not be installed:
 - (a) within category A machinery spaces;
 - (b) under sleeping accommodations;
 - (c) forward of the collision bulkhead;
 - (d) less than B/5 from ship side;
 - (e) less than 760 mm from bottom plating; and
 - (f) adjacent to the aft end of the hull.
- .7 The purposely built space in which the tank is located, shall have gas-tight boundaries to adjacent spaces and be insulated to class "A-60."
- .8 The compartment shall be provided with an addressable fire detection system and a fire suppression system in accordance with [§11.9.1](#) below.
- .9 A ventilation system of the compartment shall be provided in accordance with §10.1.3.3 and the ventilation exhaust shall be provided with flame arresting protection as required by IMO Circular MSC/Circ.677, *Revised Standards for the*

Design, Testing and Locating of Devices to Prevent the Passage of Flame into Cargo Tanks in Tankers, as amended by IMO Circulars [MSC.1/Circ.1009](#) and [MSC.1/Circ.1324](#).

- .10 A Water drainage system within the space shall be provided and capable to remove no less than 125% of the water capacity from the required fire-suppression systems, and be independent from any other drainage or bilge system. If the stability requirements are met in the event of the tank space being completely filled with water, the drainage system can be less than the capacity of the required fire suppression system.
- .11 A suitable gas detection system shall be provided within the compartment, with audible and visual alarms on the bridge and where the crew can be easily alerted.
- .12 Electrical equipment, including fixed and portable lighting, for use in the tank space and within the hazardous zone areas shall be kept to a minimum and is to be certified safe for flammable vapours. The electrical equipment and installation shall be to the rules of the RO.
- .13 Petrol system piping shall be to the rules of the RO. They shall not lead directly through accommodation or category A machinery spaces.
- .14 Tank refilling connections shall be of closed type and suitably grounded during bunkering operation
- .15 Hazardous zone areas shall be designed in accordance with the rules of the RO.
- .16 Appropriate warning signs addressing the dangers of smoking, open flames, radio transmitting equipment, etc, shall be provided in areas including, but not limited to:
 - (a) bunkering;
 - (b) dispensing;
 - (c) tank storage; and
 - (d) vent outlets.

10.1.3 Spaces Designed to Contain Vehicles

- .1 Enclosed spaces designed to contain vehicles, such as jet skis, automobiles, motorcycles, etc., with flammable liquids in their tanks shall be fitted as follows:
 - (a) with a fixed fire detection and fire alarm system complying with the requirements of SOLAS II-2 and the FSS Code, Chapter IX;

- (b) with a gas detection system with audible and visible alarms on the bridge and where the crew can be easily alerted;
 - (c) with a manually activated deluge water spray system with the capacity to cover the total area of deck and container/vehicle support platform(s) (if any) at a rate of 3.5 L/m² per minute; or for a space in which the provision of a deluge system would be inappropriate and or impractical, alternative provisions shall be made to the satisfaction of the Administrator;
 - (d) with adequate provisions for the drainage of water introduced to the space by §10.1.3.1c above. Drainage shall not lead to machinery or other spaces where a source of ignition may exist nor shall they drain directly overboard; and
 - (e) electrical equipment, including fixed and portable lighting, for use in the tank space and within the hazardous zone areas shall be kept to a minimum and is all to be certified safe for petrol vapors. The electrical equipment and installation shall be to the rules of the RO.
- .2 The location of flammable liquid storage, quantities of flammable liquid, and procedures to be followed in an emergency shall be approved and recorded on the fire safety plan and/or safety manual, as appropriate.
- .3 Areas below the weather deck shall be provided with continuous pressure-positive ventilation at each level on which vehicles are transported. Each ventilation system shall be totally independent and isolated from all other ventilated spaces:
- (a) Each ventilation outlet shall not be less than 10 m separated from any opening to an accommodation space, machinery ventilation intake, accommodation heating, ventilation and air conditioning (HVAC)/ventilation intake, or unprotected electrical source.
 - (b) The ventilation system shall be ducted and mechanically forced in order to continuously supply air to the space so that at least six air changes per hour occur based on the volume of the empty space. Any reduction of the airflow shall be signalled by both audible and visual alarms on the navigating bridge and at the “in port” control station(s).

- (c) The ventilation system shall be capable of rapid shut down and automatic closure in the event of fire.
- (d) The exhaust intake shall be located at the lowest point possible in the space.
- (e) Any fans located in the space or ducting for the space shall be certified safe for the flammable liquid and its vapor.

10.2 Saunas

- .1 The perimeter of the sauna shall be of “A” class boundaries and may include changing rooms, showers, and toilets. The sauna shall be insulated to “A-60” for yachts of 500 GT and above, A-30 for yachts of less than 500 GT, and B-15 for Category 2 yachts of less than 500 GT against other spaces except those inside the perimeter.
- .2 Bathrooms which have direct access to saunas shall comply with §10.2.1 above; except that, the door between the sauna and the bathroom is not required to comply with fire safety requirements.
- .3 Paneling and/or linings made of wood may be used on the bulkheads and ceilings of the sauna, provided that:
 - (a) the ceiling above the oven/heater shall be lined with a non-combustible plate with an air gap of at least 30 mm; and
 - (b) the distance from the oven/heater to any combustible materials shall be at least 500 mm or the combustible materials shall be protected; for example, a noncombustible plate with an air gap of at least 30 mm.
- .4 Wooden benches are permitted.
- .5 The sauna door shall open outwards by pushing from within the sauna.
- .6 An alarm or similar means which can be activated from inside the room in the case of an emergency shall be fitted. An activated alarm shall also act as an emergency stop for the oven/heater.
- .7 Electric heaters shall be fitted with a timer that will turn off the heating element within one hour.
- .8 All spaces within the perimeter of the sauna (including any bathroom(s) identified in §10.2.2 above) shall be protected by a fire detection system and a fire suppression system.

10.3 Steam Room (Thermal Suite)

- .1 The perimeter of the steam room may include changing rooms, showers, bathroom, etc.
- .2 Bathrooms which have direct access to steam rooms shall comply with [§10.2.1](#) above; except that, the door between the steam room and the bathroom is not required to comply with fire safety requirements.
- .3 If a steam generator of more than 5 kW is contained within the perimeter of the steam room, the perimeter shall be constructed of an A-0 class division (B-0 for Category 2 yachts). If a steam generator of more than 5 kW is not contained within the perimeter, then the boundaries of the spaces shall be constructed of B-0 class divisions, and the space containing the steam generator shall be protected by A-0 class divisions (B-0 for Category 2 yachts). The pipes leading to the discharge nozzles shall be lagged to an appropriate standard to avoid heat transmission.
- .4 If a steam room arrangement also contains a sauna then the requirements contained in [§10.2](#) above are applicable, regardless of the steam generator location.
- .5 All spaces within the perimeter are to be protected by a fire detection and alarm system and an automatic fire suppression system.
- .6 An alarm or similar means which can be activated from inside the room in the case of an emergency shall be fitted. An activated alarm shall also act as an emergency stop for the steam generator.

10.4 Fire Control Plans

- .1 A fire control plan shall be permanently and clearly exhibited in an easily visible and prominent place for the guidance of the Master and crew of the yacht. The plan may be a combined fire and safety plan and shall be subject to review during plan approval processes by Class. On yachts of less than 500 GT, where the Class Society has not been contracted to perform the review, this function shall be carried out by the AR.
- .2 The content of the plan shall adequately show the positions of stowage of the life-saving and fire appliances. Symbols used on the plan shall comply with the recognized international standard in accordance with *Fire Control Plans and Life-Saving Symbols* ([MN 2-011-10](#)); however, the symbols used in the fire control plan shall remain consistent to those used to identify the actual location of various equipment.

- .3 For each deck, the plan shall, at a minimum, show:
 - (a) the position of control stations;
 - (b) sections of the yacht which are enclosed respectively by “A” class divisions and “B” class divisions;
 - (c) location of flammable liquid storage (see §[10.1](#) above);
 - (d) particulars of and locations of fire alarms, fire detection systems, suppression systems, and fixed and portable fire extinguishing appliances;
 - (e) fireman’s outfit(s);
 - (f) means of access and emergency escapes for compartments and decks; and
 - (g) locations and means of control of systems and openings which should be closed down in a fire emergency.
- .4 The plan required by §10.4.1 above shall be regularly updated. Updated alterations shall be applied to all copies of the plan without delay. Each copy of the plan shall include a list of alterations and the date on which each alteration was applied.
- .5 A duplicate current plan shall be permanently stored in a prominently marked weather-tight enclosure readily accessible to assist non-yacht fire-fighting personnel who may board the yacht in a fire emergency.
- .6 Instructions relevant to the maintenance and operation of all the equipment and installations on board for the fighting and containment of fire shall be kept in one document holder, readily available in an accessible location.
- .7 All yachts shall be provided with a yacht specific training manual, as required. Refer to §[27.4](#) below.

11.0 STRUCTURAL FIRE PROTECTION FOR YACHTS OF LESS THAN 500 GT

This section establishes the criteria by which a yacht of less than 500 GT shall be built so that, in the case of a fire, it will be contained to the extent possible and that the yacht will maintain its structural integrity for the longest period possible.

11.1 Boundaries

- .1 Yachts shall be subdivided into spaces by thermal and structural divisions having due regard to the fire risks of each space.

- .2 “A” class divisions are those divisions formed by bulkheads and decks which comply with the following criteria:
- (a) they are constructed of steel or other equivalent material;
 - (b) they are suitably stiffened;
 - (c) they are constructed so as to be capable of preventing the passage of smoke and flame to the end of the one-hour standard fire test; and
 - (d) they are insulated with approved non-combustible materials such that the average temperature of the unexposed side will not rise more than 140°C above the original temperature, nor will the temperature, at any one point, including any joint, rise more than 180°C above the original temperature, within the time listed in Table 6:

Table 6

Class “A-60”	Class “A-30”	Class “A-15”	Class “A-0”
60 Minutes	30 Minutes	15 Minutes	0 Minutes

- .3 “B” class divisions are those divisions formed by bulkheads, decks, ceilings, or linings which comply with the following criteria:
- (a) they are constructed of approved non-combustible materials and all materials used in the construction and erection of “B” class divisions are non-combustible, with the exception that combustible veneers may be permitted provided they meet other appropriate requirements of this §11.0;
 - (b) they are constructed as to be capable of preventing the passage of flame to the end of the first half hour of the standard fire test; and
 - (c) they have an insulation value such that the average temperature of the unexposed side will not rise more than 140°C above the original temperature, nor will the temperature at any one point, including any joint, rise more than 225°C above the original temperature, within the time listed in Table 7:

Table 7

Class “B-15”	Class “B-0”
15 Minutes	0 Minutes

- .4 “C” class divisions are those divisions formed by bulkheads, decks, ceilings, or linings which are constructed of approved non-combustible materials.

- .5 Table 8 below outlines the thermal and structural divisions suitable for the bulkheads and decks separating adjacent spaces on yachts of less than 500 GT:

Table 8

Space	Category 0	Category 1	Category 2
Category A Machinery Spaces	A-30	B-15	B-15
Service Spaces (high risk)	B-15	B-15	B-15
Control Stations	B-15	B-0	-
Other Machinery Spaces	B-0	C	-
Service Spaces (low risk)			
Corridors	B-0	C	-
Stairways			
Accommodation Spaces	C	C	-

Table Notes:

The boundary of two adjacent spaces shall be insulated in accordance with the higher fire integrity standard.

- (1) **Category A Machinery Spaces** – Spaces so defined in SOLAS II-2.
- (2) **Service Spaces (high risk)** – Galleys, pantries containing cooking appliances, paint and lamp rooms, lockers and store-rooms having areas of 4 m² or more, spaces for the storage of flammable liquids, and workshops other than those forming part of the machinery spaces.
- (3) **Control Stations:**
 - Spaces containing emergency sources of power and lighting
 - Wheelhouse and chartroom
 - Spaces containing the yacht’s radio equipment
 - Fire control stations
 - Control room for propulsion machinery when located outside the machinery space
 - Spaces containing centralized fire alarm equipment
- (4) **Other Machinery Spaces** – Spaces so defined in SOLAS II-2, excluding machinery spaces of Category A.
- (5) **Service Spaces (low risk)** – Lockers and storerooms not having provisions for the storage of flammable liquids and having areas less than 4 m², drying rooms, and laundries.
- (6) **Corridors** – Passenger and crew corridors.
- (7) **Stairways** – Interior stairways, elevators, totally enclosed emergency escape trunks and enclosures thereto; other than those within machinery spaces; in this respect, a stairway which is enclosed only at one level shall be regarded as part of the space from which it is not separated by a fire door.
- (8) **Accommodation Spaces** – Spaces so defined in SOLAS II-2, excluding corridors.

- .6 Fire Risk Categories
- (a) To determine the appropriate fire integrity standards to be applied to divisions between adjacent spaces, such spaces shall be classified according to their fire risk as shown in Categories (1) to (8) in Table 8 above.
 - (b) Where the contents and use of a space are such that there is a doubt as to its classification for the purpose of this regulation, or where it is possible to assign two or more classifications to a space, it shall be treated as a space within the relevant Category having the most stringent boundary requirements. Smaller, enclosed rooms within a space that have less than 30% communicating openings to that space are considered separate spaces.
 - (c) The fire integrity of the boundary bulkheads and decks of such smaller rooms shall be as prescribed in Table 8 above. The title of each Category is intended to be inclusive rather than restrictive. The number preceding each Category refers to the applicable column or row in the table.
- .7 When boundaries are constructed of materials other than steel (or steel equivalent) they may be accepted by the Administrator as long as calculation methods are used, where appropriate, to determine if the boundary is:
- (a) capable of preventing the passage of smoke and flame to the end of the 60 minute standard fire test; and
 - (b) be so insulated where necessary with a suitable non-combustible material, that if the division is exposed to a standard fire test, the average temperature on the unexposed side of the division should not increase by more than 139°C above the initial temperature within a period of 30 minutes.
- .8 Steel divisions may be insulated on the side of the space posing the highest risk of fire; however, divisions of other materials shall have insulation placed on both sides.
- .9 Galleys shall be enclosed with “B-15” class divisions. Where mess rooms may be open or otherwise directly attached to the galley, it shall be considered of the same space.
- .10 In spaces where contamination of insulation by oil residues is possible, means shall be provided to protect the insulation. For yachts built of wood, or other impervious materials, similar care shall be taken.
- .11 Any opening in an “A” or “B” class division shall have permanently attached means of securing them when closed and shall provide resistance to fire (as well

as to the passage of smoke for “A” class divisions) equivalent to that of the bulkheads in which the doors are fitted.

- .12 Windows should not be fitted in machinery space boundaries.
- .13 Penetrations in fire-resisting divisions.
 - (a) Where “A” class divisions are penetrated for the passage of electric cables, pipes, trunks, ducts, etc., or for girders, beams, or other structural members, arrangements shall be made to ensure that the fire resistance is not impaired.
 - (b) Where “B” class divisions are penetrated for the passage of electric cables, pipes, trunks, ducts, etc., or for the fitting of ventilation terminals, lighting fixtures, and similar devices arrangements are to be made to ensure that the fire resistance is not impaired.
 - (c) Where “A” class divisions are not required to be insulated, it is to be ensured that the heat from a fire is not transmitted through the intersections and terminal points of the divisions or penetration to uninsulated boundaries by use of a fire tested penetration device, or other means.
- .14 Where the insulation installed does not achieve the above, arrangements are to be made to prevent this heat transmission by insulating the horizontal and vertical boundaries or penetrations for a distance of 450 mm.

11.2 Arrangement of Fuel Oil Tanks and Piping

- .1 For guidance on installation of fuel oil tanks and piping, see §[13.2](#) of this Chapter.
- .2 Fuel tanks and associated pipes and fittings shall be located so as to reduce to a minimum the risk of fire or explosion.
- .3 Every oil fuel pipe, which, if damaged, would allow oil to escape from a storage, settling, or daily service tank situated above the double bottom, shall be fitted with a cock or valve directly on the tank capable of being closed from a safe position outside the space concerned in the event of a fire occurring in the space in which such tanks are situated.
- .4 Fuel filter bowls shall be made of metal.
- .5 Surfaces that may exceed 220°C shall be insulated. Any piping connection that may, in the event of failure, drip or spray oil onto the hot surface shall be covered with approved splash tape.
- .6 Spaces containing oil tanks and piping shall be provided with an adequate and efficient ventilation system.

- .7 Fuel oil transfer pumps, purifiers, or other pumps used for the transport of oil under pressure shall be fitted with an emergency shut off outside the space.
- .8 Oil fuel tanks situated within, or adjacent to, the boundaries of Category A machinery spaces are not to contain oil fuel having a flashpoint of less than 60°C.

11.3 Ventilation

- .1 The ventilation systems provided in way of machinery spaces and galleys are to be designed to sufficiently prevent the accumulation of flammable gasses and be capable of being shut down from outside of the space.
 - (a) All inlets and outlets of the ventilation system shall be capable of being closed from outside the space.
 - (b) The locations to operate the shut off and closure as required shall be such that they are easily accessible in case of an emergency.
- .2 Ventilation ducts that feed or exhaust air from high risk areas such as machinery spaces, garages containing vehicles with fuel in their tanks, fuel storage lockers, etc., shall not pass through an accommodation space.

If this requirement is unachievable, the ducts shall be constructed of steel or other equivalent material and insulated to the same fire integrity as the space it serves. In addition, automatic fire dampers shall be fitted to the ducts where they pass through the high risk space into the accommodation space; they shall also be capable of being closed manually.

- .3 Ventilation ducts that feed or exhaust air from accommodation, service, and control spaces shall not pass through high risk areas such as machinery spaces, garages containing vehicles with fuel in their tanks, fuel storage lockers, etc.

If this requirement is unachievable, the ducts shall be constructed of steel or other equivalent material and insulated to the same fire integrity as the high risk area through which it passes. In addition, automatic fire dampers shall be fitted to the ducts, where they pass through the accommodation space into the high risk area, on the accommodation side of the ducts that pass through the high risk area. The automatic fire dampers shall also be capable of being closed manually.

- .4 Storage rooms that contain highly flammable products shall be provided with ventilation that is separate and independent of other ventilation systems. The inlets and outlets of the systems shall be positioned as to pose the lowest risk possible and shall be fitted with flame arrestors.

- .5 Ventilation serving Category A machinery spaces shall be separate and independent of systems serving other spaces.
- .6 Ventilation serving enclosed spaces containing free standing fuel tanks shall be separate and independent of systems serving other spaces.
- .7 Ventilation shall be provided for areas where batteries are stored in order to prevent dangerous accumulations of flammable gas.
- .8 The ducts of exhaust ventilation for clothing driers shall be provided with access at suitable locations for cleaning and inspection.
- .9 Exhaust ducts from galley ranges shall be fitted with suitable means for extinguishing and containing the fire within the duct. Exhaust ducts that pass through accommodation spaces shall be fitted with additional fire dampers at the accommodation boundaries. This system shall be to the satisfaction of the RO.

11.4 Means of Escape

- .1 In order to aid with the escape of persons on board in the case of an emergency, means shall be provided to provide quick and safe access to the life raft embarkation deck.
- .2 The arrangement of the hull shall be such that all under deck compartments are provided with a satisfactory means of escape. In the case of the under deck and above deck accommodations and engine room spaces, two means of escape from every restricted space or group of spaces shall be provided.

Only in exceptional cases will one means of escape be accepted by the Administrator, and then only if the means of escape provided does not require passage through a hazardous area, e.g., a galley or engine room, leads directly to the open air, and it can be demonstrated that the provision or retrofitting of a second means of escape would be impractical or detrimental to the overall safety of the yacht.

- .3 Secondary means of escape which pass through windows or hatches, shall have a minimum clear opening not less than 600 mm by 600 mm and shall provide escape to an open deck:
 - (a) Where a second means of escape is via a sealed window, breakable glass, not polycarbonate or laminated glass, which can be readily broken with a conveniently located crash hammer, is acceptable.
 - (b) Where not practicable to comply with the sill requirements, weatherdeck flush hatches may be used as a secondary escape from the accommodation spaces.

- (c) The Administrator may consider, on a case-by-case basis, a second means of escape from an accommodation space that leads via a hatch into another space.
- .4 All doors and hatches in escape routes shall be able to be opened from either side to allow for escape from and entry into the space (e.g., by rescue workers). In the direction of escape, they shall be able to be opened without the use of a key. All handles on the inside of weather-tight doors and hatches shall be non-removable.
- .5 In the accommodation, where concealed escapes and routes may be used, they both are to be clearly marked.
- .6 All escapes and escape routes shall be kept clear of any other item or fitting that may impede escape during an emergency.
- .7 The design of the escapes and escape routes shall be in accordance with international conventions and codes.

11.5 Materials

- .1 Insulating materials shall be non-combustible except in refrigerated compartments. Vapor barriers and adhesives used in conjunction with insulation, as well as the insulation of pipe fittings for cold service systems, need not be of non-combustible materials, but they shall be kept to the minimum quantity practicable and their exposed surfaces shall have low flame-spread characteristics.
- .2 Pipes that penetrate “A” or “B” class divisions are to be of an approved material that takes into account the temperature such divisions are required to withstand as well as the liquid (e.g., oil or other combustible) carried.
- .3 Materials that may be readily rendered ineffective by heat are not to be used for overboard scuppers, sanitary discharges, and other outlets which are close to the waterline, the failure of which would give rise to danger of flooding. The requirements of the 2010 FTP Code shall be applied.
- .4 Except for spaces fitted with an appropriate, approved fixed fire extinguishing system, upholstery composites (fabric in association with any backing or padding material) used throughout the yacht shall be approved in accordance with the 2010 FTP Code, or an equivalent standard.
- .5 Organic foams used in upholstered furniture and mattresses shall be of the combustion-modified type satisfying the fire test procedures of the 2010 FTP Code, or an equivalent standard.

- .6 Except for spaces fitted with an appropriate approved fixed fire extinguishing system, suspended textile materials such as curtains or drapes shall be approved in accordance with the 2010 FTP Code, or an equivalent standard.

11.6 Open Flame Gas Appliances and Recreational Fire Appliances (RFAs)

- .1 An open flame gas appliance provided for cooking, heating, or any other purpose shall comply with the requirements of ISO 10239:2014 or an equivalent standard.
- .2 RFAs as defined in Chapter 1 shall meet the requirements of *Recreational Fire Appliances* ([MN 2-011-57](#)).

11.7 Deep Fat Cooking Equipment

The provisions of SOLAS II-2 should be complied with as far as is reasonable and practicable for all deep fat cooking equipment installed.

11.8 Paints, Varnishes, and Other Finishes

Paints, varnishes, and other finishes which pose an undue fire hazard shall not be used in the engine room, galley, or in other areas of high fire risk. Elsewhere such finishes should be kept to a minimum.

11.9 Fire Detection and Fire Alarm Systems

- .1 A fire detection and fire alarm system shall be installed in accordance with SOLAS II-2 and the FSS Code. The system shall be provided with a control panel located within the wheelhouse and audible alarms provided in locations where they are most likely to be heard. The system shall be comprised of smoke, heat, or other suitable detectors fitted in the machinery space and galley as a minimum; and in yachts of 30 m or more in length, suitable detectors shall be fitted in all enclosed spaces except those that afford no substantial fire risk such as toilets, bathrooms, void spaces, etc. Manually operated call points shall be placed to ensure a readily accessible means of notification.
- .2 In the exceptional case of a space or compartment having only one means of escape (§11.4 above), the integrity of the escape route shall be protected by the installation of fire detectors that give instantaneous early warning of danger by means of audible and visible alarms in the space or compartment, audible throughout the yacht.
- .3 The installation of fixed fire extinguishing systems not required by this Code shall be done to the satisfaction of the RO.

12.0 STRUCTURAL FIRE PROTECTION FOR YACHTS OF 500 GT AND ABOVE

This section establishes the criteria by which a yacht of 500 GT and above shall be built so that, in the case of a fire, it will be contained to the extent possible and that the yacht will maintain its structural integrity for the longest period possible.

12.1 Boundaries

- .1 Yachts shall be subdivided into spaces by thermal and structural divisions having due regard to the fire risks of each space.
- .2 “A” class divisions are those divisions formed by bulkheads and decks which comply with the following criteria:
 - (a) they are constructed of steel or other equivalent material;
 - (b) they are suitably stiffened;
 - (c) they are constructed so as to be capable of preventing the passage of smoke and flame to the end of the one-hour standard fire test; and
 - (d) they are insulated with approved non-combustible materials such that the average temperature of the unexposed side will not rise more than 140°C above the original temperature, nor will the temperature, at any one point, including any joint, rise more than 180°C above the original temperature, within the time listed in Table 9:

Table 9

Class “A-60”	Class “A-30”	Class “A-15”	Class “A-0”
60 Minutes	30 Minutes	15 Minutes	0 Minutes

- .3 “B” class divisions are those divisions formed by bulkheads, decks, ceilings, or linings which comply with the following criteria:
 - (a) they are constructed of approved non-combustible materials and all materials used in the construction and erection of “B” class divisions are non-combustible, with the exception that combustible veneers may be permitted provided they meet other appropriate requirements of §[12](#) to §[12.27](#) of this Chapter;
 - (b) they are constructed as to be capable of preventing the passage of flame to the end of the first half hour of the standard fire test;
 - (c) they have an insulation value such that the average temperature of the unexposed side will not rise more than 140°C above the original temperature, nor will the temperature at any one point, including any joint,

rise more than 225°C above the original temperature, within the time listed in Table 10:

Table 10

Class “B-15”	Class “B-0”
15 Minutes	0 Minutes

- .4 “C” class divisions are those divisions formed by bulkheads, decks, ceilings, or linings which are constructed of approved non-combustible materials.

12.2 Fire Integrity

- .1 Tables 11 and 12 below outline the thermal and structural divisions suitable for the bulkheads and decks of yachts of 500 GT and above. In addition to the tables, the fire integrity of bulkheads and decks shall be as per the relevant sections found in this section.
- (a) In determining the applicable fire integrity standard of a boundary between two spaces within a main vertical zone or horizontal zone which is protected by a fire suppression system between such zones, both of which are so protected, the lesser of the two values given in the Tables below shall apply.
- (b) Where a zone protected by an automatic sprinkler system and a zone which is not protected meet within accommodation and service spaces, the higher of the two values given in Tables 11 and 12 below shall apply to the division between the zones.

Table 11

Fire Integrity of Bulkheads Separating Adjacent Spaces

Space	1	2	3	4	5	6	7	8	9
Control Station	A-0 ^c	A-0	A-60	A-0	A-15	A-60	A-15	A-60	*
Corridors	-	C ^d	B-0 ^d	A-0 ^a B-0 ^d	B-0 ^d	A-60	A-0	A-0	*
Accommodation Spaces	-	-	C ^d	A-0 ^a B-0 ^d	B-0 ^d	A-60	A-0	A-0	*
Stairways	-	-	-	A-0 ^a B-0 ^d	A-0 ^a B-0 ^d	A-60	A-0	A-0	*
Service Spaces (low risk)	-	-	-	-	C ^d	A-60	A-0	A-0	*
Category A Machinery Spaces	-	-	-	-	-	*	A-0	A-60	*
Other Machinery Spaces	-	-	-	-	-	-	A-0 ^b	A-0	*

Table 11
Fire Integrity of Bulkheads Separating Adjacent Spaces

Space	1	2	3	4	5	6	7	8	9
Service Spaces (high risk)	-	-	-	-	-	-	-	A-0 ^b	*
Open Decks	-	-	-	-	-	-	-	-	*

Table 12
Fire Integrity of Decks Separating Adjacent Spaces

Spaces Above Spaces Below	1	2	3	4	5	6	7	8	9
Control Station	A-0	A-0	A-0	A-0	A-0	A-60	A-0	A-0	*
Corridors	A-0	*	*	A-0	*	A-60	A-0	A-0	*
Accommodation Spaces	A-60	A-0	*	A-0	*	A-60	A-0	A-0	*
Stairways	A-0	A-0	A-0	*	A-0	A-60	A-0	A-0	*
Service Spaces (low risk)	A-15	A-0	A-0	A-0	*	A-60	A-0	A-0	*
Category A Machinery Spaces	A-60	A-60	A-60	A-60	A-60	*	A-60 ^c	A-60	*
Other Machinery Spaces	A-15	A-0	A-0	A-0	A-0	A-0	*	A-0	*
Service Spaces (high risk)	A-60	A-0	A-0	A-0	A-0	A-60	A-0	A-0	*
Open Decks	*	*	*	*	*	*	*	*	*

Table Notes (to be applied to both Tables 11 and 12 as appropriate):

- a. Where spaces are of the same numerical Category A and superscript b appears, a bulkhead or deck of the rating shown in the Tables is only required when the adjacent spaces are for a different purpose; e.g., in Category A, a galley next to a galley does not require a bulkhead but a galley next to a paint room requires an “A-0” bulkhead.
- b. Bulkheads separating the wheelhouse and chartroom from each other may be “B-0” rating.
- c. See §12.0 for clarification of what applies if the item is not listed in the table.
- d. For the application of §12.7.1, “B-0” and “C,” where appearing in Table 11, should be read as “A-0.”
- e. Fire insulation need not be fitted if the machinery space in Category A, in the opinion of the Administrator or its representative, has little or no fire risk.

* *Where an asterisk appears in Tables 11 and 12, the division is required to be of steel or other equivalent material but is not required to be of “A” class standard. For the application of an asterisk, where appearing in Table 12, except for Category A, should be read as “A-0.”*

(1) Control Stations:

- Spaces containing emergency sources of power and lighting
- Wheelhouse and chartroom
- Spaces containing the yacht’s radio equipment
- Fire control stations
- Control room for propulsion machinery when located outside the machinery space
- Spaces containing centralized fire alarm equipment

(2) Corridors – Passenger and crew corridors.

(3) Accommodation Spaces – Spaces so defined in SOLAS II-2, excluding corridors.

(4) Stairways – Interior stairways, elevators, totally enclosed emergency escape trunks and enclosures thereto; other than those within machinery spaces; in this respect, a stairway which is enclosed only at one level shall be regarded as part of the space from which it is not separated by a fire door.

(5) Service Spaces (low risk) – Lockers and storerooms not having provisions for the storage of flammable liquids and having areas less than 4 m², drying rooms, and laundries.

(6) Category A Machinery Space – Spaces so defined in SOLAS II-2.

(7) Other Machinery Spaces – Spaces so defined in SOLAS II-2, excluding machinery spaces of Category A.

(8) Service Spaces (high risk) – Galleys, pantries containing cooking appliances, paint and lamp rooms, lockers and storerooms having areas of 4 m² or more, spaces for the storage of flammable liquids, and workshops other than those forming part of the machinery spaces. Pantries shall meet the requirements for the fitting of equipment as per MSC/Circ.1120.

(9) Open Decks – Open deck spaces and enclosed promenades having little or no fire risk. Such spaces should be primarily naturally ventilated by permanent means. Air spaces (the space outside superstructures and deckhouses).

12.3 Fire Risk Categories

- .1 To determine the appropriate fire integrity standards to be applied to divisions between adjacent spaces, such spaces shall be classified according to their fire risk as shown in Categories (1) to (9) above.

- .2 Where the contents and use of a space are such that there is a doubt as to its classification for the purpose of this regulation, or where it is possible to assign two or more classifications to a space, it shall be treated as a space within the relevant Category having the most stringent boundary requirements. Smaller, enclosed rooms within a space that have less than 30% communicating openings to that space are considered separate spaces.
- .3 The fire integrity of the boundary bulkheads and decks of such smaller rooms shall be as prescribed in Tables 11 and 12 above. The title of each Category is intended to be inclusive rather than restrictive. The number preceding each Category refers to the applicable column or row in the tables.
- .4 Continuous “B” class ceilings or linings, in association with the relevant decks or bulkheads, may be accepted as contributing, wholly or in part, to the required insulation and integrity of a division.
- .5 External boundaries, which are required to be of steel or other equivalent material, may be pierced for the fitting of windows and side scuttles provided that there is no requirement for such boundaries of passenger ships to have “A” class integrity. Similarly, in such boundaries which are not required to have “A” class integrity, doors may be constructed of materials which are to the satisfaction of the Administrator.

12.4 Openings in “A” Class Divisions

- .1 Except for hatches between store and baggage spaces, and between such spaces and the weather decks, openings shall be provided with permanently attached means of closing which shall be at least as effective for resisting fires as the divisions in which they are fitted.
- .2 The construction of doors and door frames in “A” class divisions, together with the means of securing them when closed, shall provide resistance to fire as well as the passage of smoke and flame, as far as is reasonable and practicable, equivalent to that of the bulkheads in which the doors are situated.
- .3 The doors and door frames referred to in §12.4.2 above shall be constructed of steel or other equivalent material. Watertight doors need not be insulated.
- .4 Each door shall be able to be opened and closed from each side of the bulkhead by one person only.
- .5 Fire doors in main vertical zone bulkheads, galley boundaries, and stairway enclosures, other than power-operated watertight doors and those which are normally locked, shall satisfy the following requirements.
 - (a) The doors shall be of the self-closing type and capable of closing against an inclination of 3.5° opposing closure.

- (b) The speed of door closure shall be controlled to prevent undue danger to persons, but in no case shall the speed of the door closure be greater than 40 seconds.
- (c) The doors, except those that are normally closed or are for an emergency escape trunk, shall be capable of remote release from a control station, either simultaneously or in groups, and shall also be capable of manual release individually from a position at both sides of the door.
- (d) Doors with hold-back devices not subject to control station release are not permitted.
- (e) A door closed remotely from the central control station shall be capable of being reopened from both sides of the door by local control, after which, the door shall automatically close again.
- (f) The release mechanism of the doors shall be so designed that they will automatically close in the event of disruption of the control system; however, approved power-operated watertight doors will be considered acceptable for this purpose.
- (g) Local power accumulators for hydraulically operated doors shall be provided in the immediate vicinity of the doors to enable the doors to be operated at least 10 times (fully opened and closed) after disruption of the control system or central power supply using the local controls.
- (h) The fire door indicator panel in the control station shall be equipped so as to indicate whether each door is closed.
- (i) Disruption of the control system or central power supply at one door shall not impair the safe functioning of the other doors.
- (j) Remote-released sliding or power-operated doors shall be equipped with an alarm that sounds at least five seconds but no more than 10 seconds after the door is released from the central controls station and before the door begins to move. This alarm shall be such that it continues sounding until the door is completely closed.
- (k) A door designed to reopen upon contacting an object in its path shall reopen not more than 1 m from the point of contact.
- (l) Double-leaf doors equipped with a latch necessary for their fire integrity shall have a latch that is automatically activated by the operation of the doors when released by the system.

- (m) The components of the local control system shall be readily accessible for maintenance and adjusting.
 - (n) When double swing doors are permitted by the Administrator, they shall have a latch arrangement that is automatically engaged by the operation of the door release system.
 - (o) Power-operated doors shall be provided with a control system of an Approved Type which shall be able to operate in case of fire and be in accordance with the 2010 FTP Code. This system shall satisfy the following requirements:
 - (i) the control system shall be able to operate the door at a temperature of at least 200°C for at least 60 minutes, served by the power supply;
 - (ii) the power supply for all other doors not subject to fire shall not be impaired; and
 - (iii) at temperatures exceeding 200°C the control system shall be automatically isolated from the power supply and shall be capable of keeping the door closed up to a temperature of at least 945°C.
- .6 When a space is protected by an automatic sprinkler system complying with the provisions of §[12.16](#) below or fitted with a continuous “B” class ceiling, openings in decks not forming steps in main vertical zones nor bounding horizontal zones shall be closed reasonably tight and such decks shall meet the “A” class integrity requirements in so far as is reasonable and practicable.
- .7 Where “A” class divisions are penetrated by such items as electric cables, pipes, trunks or ducts, or for girders, beams, or other structural members, arrangements shall be made to ensure that the fire resistance is not impaired.

12.5 Openings in “B” Class Divisions

- .1 Doors and door frames in “B” class divisions and means of securing them shall provide a method of closure which shall have resistance to fire, to the extent reasonable and practicable, equivalent to that of the divisions, except that a ventilation opening may be permitted in the lower portion of such doors. Where such openings are in or under a door, the total net area of the opening(s) shall not exceed 0.05 m². All ventilation openings shall be fitted with a grill made of non-combustible material. Doors shall be of non-combustible construction as far as is reasonable and practicable.
- .2 The requirements for “B” class division of the outer boundaries of a yacht shall not apply to glass partitions, windows, and side scuttles. Similarly, the requirements for “B” class divisions shall not apply to exterior door.

- .3 When a fixed fire suppression system complying with the provisions of §[12.16](#) below is fitted:
 - (a) openings in decks not forming steps in main vertical zones nor bounding horizontal zones shall be closed reasonably tight and such decks shall meet the “B” class integrity requirements, as far as is reasonable and practicable; and
 - (b) openings in corridor bulkheads of “B” class materials shall be protected in accordance with the provisions of §12.5.1 above.

12.6 Windows and Side Scuttles

- .1 All windows and side scuttles in bulkheads within accommodation, service spaces, and control stations shall be so constructed to preserve the integrity requirements of the type of bulkheads in which they are fitted.
- .2 Notwithstanding the requirements of Tables 11 and 12 above, all windows and side scuttles in bulkheads separating accommodation, service spaces, and control stations from weather shall be constructed with frames of steel or other suitable material. A metal glazing bead or angle shall retain the glass.
- .3 With regard to conditions of assignment for windows and side scuttles/portlights, see §[5.4](#) and §[5.5](#) above.

12.7 Main Vertical Zones and Horizontal Zones

- .1 Hull superstructure and deckhouses in way of accommodation and service spaces shall be subdivided into main vertical zones by “A” class divisions. These divisions shall have insulation values in accordance with Tables 11 and 12 in §[12.2](#) above.
- .2 As far as reasonable and practicable, the bulkheads forming the boundaries of the main vertical zones shall be in line with watertight subdivision bulkheads; or
- .3 As far as reasonable and practicable, the bulkheads forming the boundaries of the main vertical zones above the bulkhead deck shall be in line with watertight subdivision bulkheads situated immediately below the bulkhead deck. The length and width of main vertical zones may be extended to a maximum of 48 m in order to bring the ends of main vertical zones to coincide with watertight subdivision bulkheads or in order to accommodate a large public space extending for the whole length of the main vertical zone provided that the total area of the main vertical zone is not greater than 800 m² on any deck. The length or width of a main vertical zone is the maximum distance between the furthestmost points of the bulkheads bounding it.

- .4 Such bulkheads shall extend from deck to deck and to the shell or other boundaries.
- .5 When a main vertical zone is subdivided by “A” class divisions for the purpose of providing an appropriate barrier between spaces protected by a fire suppression system and a space which is not protected, the divisions shall be insulated in accordance with the class division values given in Tables 11 and 12 above.

12.8 Bulkheads Within a Main Vertical Zone

- .1 All bulkheads within accommodation and service spaces which are not required to “A” class divisions shall be at least “B” class or “C” class divisions as prescribed in Tables 11 and 12 in §[12.2](#) above.
- .2 All corridor bulkheads where not required to be “A” class shall be “B” class divisions which shall extend from deck to deck except:
 - (a) when continuous “B” class ceilings or linings are fitted on both sides of the bulkhead, the portion of the bulkhead behind the continuous ceilings or linings shall be of material which, in thickness and composition, is acceptable in the construction of “B” class divisions, but which shall be required to meet “B” class standards so far as is reasonable and practicable in the opinion of the Administrator; and
 - (b) in the case of a yacht protected by an automatic fire suppression system complying with the provisions of the FSS Code, the corridor bulkheads of “B” class materials may terminate at a ceiling in the corridor provided such a ceiling is of material which, in thickness and composition, is acceptable in the construction of “B” class standards. All doors and frames in such bulkheads shall be so constructed and erected to provide equivalent fire resistance.
- .3 All bulkheads required to be “B” class divisions, except corridor bulkheads, shall extend from deck to deck and to the shell or other boundaries unless continuous “B” class ceilings or linings are fitted on both sides of the bulkhead, in which case the bulkhead may terminate at the continuous ceiling or lining.
- .4 All such divisions may be faced with combustible materials in accordance with the provisions of §[12.1.3](#) above

12.9 Structural Integrity

- .1 The hull, superstructures, structural bulkheads, decks, and deckhouses shall be constructed of steel or other equivalent material.

- .2 However, in cases where any part of the structure is of aluminum alloy, the following shall apply.
- (a) Insulation of aluminum alloy components of “A” or “B” class divisions, except structure that, in the opinion of the Administrator, is non-load-bearing, shall be such that the temperature of the structural core does not rise more than 200°C above the ambient temperature at any time during the applicable fire exposure to the standard fire test;
 - (b) Special attention shall be given to the insulation of aluminum alloy components of columns, stanchions, and other structural members required to support lifeboat and life raft stowage, launching, and embarkation areas, and “A” and “B” class divisions to ensure that for members:
 - (i) supporting lifeboat and life raft areas and “A” class divisions, the temperature rise limitation specified in (a) shall apply at the end of 60 minutes; and
 - (ii) supporting “B” class divisions, the temperature rise limitation specified in (a) shall apply at the end 30 minutes.
 - (c) Aluminum alloy components of divisions that are required to be equivalent to steel (identified by an asterisk in Tables 11 and 12 in §[12.2](#) above) shall be insulated with 25 mm of mineral wool approved for use in “A” class divisions or with an equivalent insulation acceptable to the Administrator.
- .3 Crowns and casings of a Category A machinery space shall be of steel construction; where this is not reasonable or practical they are to be “A-60” class divisions. In either case, any openings therein shall be arranged and protected to prevent the spread of fire.
- .4 The floor plating, its supporting structure, and stairs in Category A machinery spaces shall be made of steel. Where this is not reasonable or practicable, aluminum floor plates and supporting structure may be used provided that:
- (a) floorplates with unsupported spans of more than 550 mm are additionally stiffened to reduce deflection; and
 - (b) the machinery space bilges are fitted with an appropriate fixed fire suppression system.
- .5 Materials readily rendered ineffective by heat shall not be used for overboard scupper, sanitary discharges, and other outlets which are close to the waterline and where the failure of the material in the event of fire would give rise to danger of flooding.
- .6 For composite structures, the insulation is to be such that the temperature of the laminate does not rise more than the minimum temperature of deflection under

load of the resin at any time during the specified fire exposure. This insulation is to be applied on all sides except for the upper sides of decks and the outside of the yacht.

- (a) Special attention shall be given to the insulation of composite components of columns, stanchions, and other structural members required to support lifeboat and life raft stowage, launching, and embarkation areas, and “A” and “B” class divisions to ensure that:
 - (i) when supporting lifeboat and life raft areas and “A” class divisions, the temperature rise limitation specified in §[12.9.2](#) above shall apply at the end of one hour; or
 - (ii) when supporting “B” class divisions, the temperature rise limitation specified in §[12.9.2](#) above shall apply at the end of half an hour.
- .7 For structures in contact with seawater, the required insulation shall extend to at least 300 mm below the lightest waterline.
- .8 Fire divisions using steel equivalent or alternative forms of construction may be accepted if it can be demonstrated to the satisfaction of the Administrator that the material by itself, or due to non-combustible insulation provided, has the fire resistance properties equivalent to the “A” or “B” class divisions standards.
- .9 Insulation required by §12.9.8 above is to be such that the temperature of the structural core does not rise above the point at which the structure would begin to lose its strength at any time during the applicable exposure to the standard fire test. For “A” class divisions, the applicable exposure is 60 minutes, and for “B” class divisions, the applicable exposure is 30 minutes.

12.10 Details of Construction

- .1 In accommodation and service spaces, control stations, corridors, and stairways:
 - (a) air spaces enclosed behind ceilings, paneling, or linings shall be suitably divided by close-fitting draught stops not more than 14 m apart; and
 - (b) in the vertical direction, enclosed air spaces, including those behind linings of stairways and trunks, shall be closed at each deck.
- .2 The draught stops are to be non-combustible and are to form a continuation above the ceiling of the bulkhead below or the other side of the paneling or lining to the bulkhead, as far as possible.
- .3 Where the structure or “A” class divisions are required to be insulated, it is to be ensured that the heat from a fire is not transmitted through the intersections and terminal points of the divisions or penetrations to un-insulated boundaries. Where

the insulation installed does not achieve this, arrangements are to be made to prevent this heat transmission by insulating the horizontal and vertical boundaries or penetration for 450 mm.

- .4 Without impairing the efficiency of the fire protection, the construction of ceilings and bulkheads should allow a fire patrol to detect any smoke originating in concealed and inaccessible places, except where there is no risk of fire originating in such places.
- .5 When gaseous fuel is used for domestic purposes, the arrangements for the storage, distribution, and utilization of the fuel shall be such that, having regard to the hazards of fire and explosion which the use of such fuel may entail, the safety of the yacht and the persons on board are preserved.

12.11 Ventilation Systems

- .1 Ventilation systems shall comply with SOLAS II-2.
- .2 A mark identifying where a fire damper can be manually closed shall be provided.
- .3 Power ventilation of accommodation spaces, service spaces, control stations, and machinery spaces shall be capable of being stopped from an easily accessible position outside the space being served. This position should not be readily cut off in the event of a fire in the spaces served. The means provided for stopping the power ventilation of a machinery space shall be entirely separate from the means provided for stopping ventilation of other spaces.
- .4 Where public spaces span three or more open decks and contain combustibles such as furniture and other enclosed spaces, the spaces are to be equipped with a smoke extraction system. The smoke extraction system is to be activated by the smoke detection system required by §[12.17](#) below and is to be capable of manual control. The fans are to be capable of exhausting the entire volume within the space in not more than 10 minutes.
- .5 Ventilations systems serving Category A machinery spaces are to be independent of systems serving other spaces.
- .6 All enclosed spaces containing free standing fuel tanks are to ventilate independently of systems serving other spaces.
- .7 Ventilation is to be provided to prevent the accumulation of dangerous concentration of flammable gas which may be emitted from batteries.
- .8 Ventilation openings may be fitted in and under the lower parts of cabin and public space doors fitted in corridor bulkheads. The total net area of any such opening is not to exceed 0.05 m².

- .9 For spaces containing vehicles or craft with fuel in their tanks or lockers storing such fuels, see §[10.1.1](#) and §[10.1.3](#) above.
- .10 The ducts of exhaust ventilation for clothing driers shall be provided with access at suitable locations for cleaning and inspection.
- .11 All fire dampers shall comply with IMO Resolution [A.754\(18\)](#), *Recommendation on Fire Resistance Tests for “A”, “B” and “F” Class Divisions*, as amended by IMO Resolution [MSC.61\(67\)](#), and as referenced in the 2010 FTP Code.

12.12 Protection of Stairways and Elevators (Lifts) in Accommodation and Service Spaces

- .1 Stairways shall be constructed of steel, or equivalent material, and shall be within enclosures formed of “A” class divisions, with positive means of closure at all openings except that:
 - (a) a stairway which penetrates only a single deck may be protected at one level only by at least “B” class divisions and self-closing door(s); and
 - (b) stairways may be fitted in the open in a public space, provided they lie wholly within the public space.
- .2 Stairway enclosures shall have direct communication with corridors and shall have a sufficient area to prevent congestion, considering the number of persons which may use them in an emergency.

In so far as is reasonable and practicable, stairway enclosures should not give direct access to cabins, service lockers, or other enclosed spaces containing combustibles in which a fire is likely to originate.
- .3 Elevator (lift) trunks shall be so fitted to prevent the passage of smoke and flame from one ‘tween-deck to another and shall be provided with means of closing so as to permit the control of draft and smoke.

12.13 Means of Escape

12.13.1 Accommodation and Service Spaces

Stairways and ladders shall be arranged to provide ready means of escape to the life raft and/or lifeboat embarkation deck from all accommodation and service spaces other than machinery spaces. In particular, the following provisions shall be complied with:

- (a) Below the bulkhead deck two means of escape, at least one of which shall be independent of watertight doors, shall be provided from each watertight compartment or similarly restricted group of spaces. The Administrator may

allow one of the means of escape to be dispensed with upon consideration of the nature and location of the spaces and the number of persons who might normally be accommodated or employed there.

- (b) Above the bulkhead deck there shall be at least two means of escape from each main vertical zone or similarly restricted group of spaces.
- (c) Where it is reasonable and practicable within each main vertical zone there shall be at least one readily accessible enclosed stairway providing continuous fire shelter at all levels up to the appropriate life raft and/or lifeboat embarkation deck or the highest level served by the stairway, whichever level is the highest. The width, number, and continuity of the stairways shall be satisfactory for the number of persons which may use them.
- (d) Protection of access from the stairway enclosures to the lifeboat and life raft embarkation areas shall be provided either directly or through protected internal routes which have fire integrity and insulation values for stairway enclosures as determined by Tables 11 and 12 in §12.2 above.
- (e) Stairways serving only a space and a balcony in that space shall not be considered as forming one of the required means of escape.
- (f) If a radio room or wheelhouse has no direct access to the open deck, two means of escape shall be provided, one of which may be a window which complies with §12.13.1g below.
- (g) Secondary means of escape which pass through windows or hatches shall have a minimum clear opening not less than 600 mm by 600 mm and shall provide escape to an open deck:
 - (i) Where a second means of escape is via a sealed window, breakable glass, not polycarbonate or laminated glass, which can be readily broken with a conveniently located crash hammer, is acceptable.
 - (ii) Where not practicable to comply with the sill requirements, weatherdeck flush hatches may be used as a secondary escape from the accommodation spaces.
 - (iii) The Administrator may consider on a case-by-case basis, a second means of escape from an accommodation space that leads via a hatch into another space.
- (h) All doors and hatches in escape routes shall be able to be opened from either side to allow for escape from and for entry into the space (e.g., by rescue workers). In the direction of escape, they shall be able to be opened without the use of a key. All handles on the inside of weather-tight doors and hatches shall be non-removable.

12.13.2 Machinery Spaces

Two means of escape shall be provided from each machinery space. The following provisions shall be complied with:

- (a) Below the bulkhead deck either:
 - (i) two sets of steel ladders should be installed, as widely separated from each other as possible, leading to doors in the upper part of the space similarly separated and from which access is provided to the appropriate life raft and/or lifeboat embarkation deck. One of these ladders shall provide continuous fire shelter from the lower part of the space to a safe position outside the space; or
 - (ii) one steel ladder should be installed leading to a door in the upper part of the space from which access is provided to the embarkation deck. Additionally, in the lower part of the space and in a position well separated from the ladder referred to, one steel door capable of being operated from each side should be installed. This door should provide access to a safe escape route from the lower part of the space to the embarkation deck.
- (b) Above the bulkhead deck where two means of escape are not reasonable and practical, one of the means of escape may be dispensed with, keeping in mind the width and arrangement and use of the upper part of the space.
- (c) Two means of escape shall be provided from a machinery control room located within a machinery space, at least one of which shall provide continuous fire shelter to a safe position outside the machinery space.
- (d) Ladders forming the means of escape shall be made of steel or equivalent material.
- (e) In no case shall elevators (lifts) be considered as forming one of the required means of escape.
- (f) Furniture in the corridors and escape routes shall be of a type and quantity not likely to obstruct access. In addition, furniture further along the escape routes shall be secured so as to prevent movement in the case of the yacht rolling or listing.
- (g) Secondary means of escape which pass through windows or hatches shall have a minimum clear opening not less than 600 mm by 600 mm and shall provide escape to an open deck:
 - (i) Where a second means of escape is via a sealed window, breakable glass, not polycarbonate or laminated glass, which can be readily broken with a conveniently located crash hammer, is acceptable.

- (ii) Where not practicable to comply with the sill requirements, weatherdeck flush hatches may be used as a secondary escape from the accommodation spaces.
 - (iii) The Administrator may consider on a case-by-case basis, a second means of escape from an accommodation space that leads via a hatch into another space.
- (h) All doors and hatches in escape routes shall be able to be opened from either side to allow for escape from and for entry into the space (e.g., by rescue workers). In the direction of escape, they shall be able to be opened without the use of a key. All handles on the inside of weather-tight doors and hatches shall be non-removable.

12.14 Materials

- .1 Except in spaces protected by an automatic fire suppression system and fully addressable fire detection system in accordance with §[12.16](#) below, all linings, grounds and ceilings shall be of non-combustible materials. Core insulation of refrigeration and cold rooms need not to be of non-combustible material.
- .2 Vapor barriers and adhesives used in conjunction with insulation, as well as insulation of pipe fittings for cold service systems need not be non-combustible, but shall be kept to the minimum quantity practicable and their exposed surfaces shall be low flame spread.
- .3 The following surfaces shall be low flame spread:
 - (a) exposed surfaces in corridors and stairway enclosures, bulkheads, wall and ceiling linings in all service spaces, and control stations; and
 - (b) concealed or inaccessible spaces in accommodation, service spaces, and control stations.
 - (c) As an alternative to (a) and (b) above, these spaces may contain surfaces that are not low flame spread, provided that:
 - (i) adequate barriers of low flame spread surfaces are arranged to restrict the spread of flame areas at distances not greater than 5 m; or
 - (ii) these spaces are protected by an automatic fire suppression system and fully addressable fire detection system in accordance with §[12.16](#) below.

- .4 Pipes penetrating “A” or “B” class divisions are to be of approved materials having regard to the temperature such divisions are required to withstand.
- .5 Pipes conveying oil or combustible liquids through accommodation and service spaces are to be of approved materials having regard to the fire risk.
- .6 The total volume of combustible facings, moldings, decorations, and veneers in any accommodation and service space not protected by a system complying with §12.16 or §12.17 below, shall not exceed a volume equivalent to 2.5 mm veneer on the combined area of the walls and ceilings.
- .7 Materials readily rendered ineffective by heat shall not be used for overboard scuppers, sanitary discharges, and other outlets which are close to the waterline and where the failure of the material in the vent of fire would give rise to the danger of flooding.
- .8 Primary deck coverings, if applied within accommodation, service spaces, and control stations, shall not be of material that is readily ignitable, nor give off toxic or explosive hazards at elevated temperatures. In this regard, reference shall also be made to the 2010 FTP Code, and applied as required.
- .9 Upholstery composites (fabric in association with any backing or padding material) used throughout the yacht shall satisfy fire test procedures of the 2010 FTP Code, or an equivalent standard; and
 - (a) organic foams used in upholstered furniture and mattresses shall be of the combustion modified type satisfying the fire test procedures of the 2010 FTP Code, or an equivalent standard; and
 - (b) suspended textile materials such as curtains and drapes shall satisfy the fire test procedures of the 2010 FTP Code, or be of equivalent standard.

If a fully addressable fire detection system is fitted, the requirement in this §12.14.9 may be dispensed with.

- .10 In spaces where penetration of oil products is possible, the surface of insulation is to be impervious to oil or oil vapors. Insulation boundaries are to be arranged to avoid immersion in oil spillages so far as is reasonable and practicable.

12.15 Deep Fat Cooking Equipment

The provisions of SOLAS II-2 shall be complied with for any deep fat cooking equipment fitted on the yacht.

12.16 Suppression of Fire

- .1 Each separate zone in all accommodation and service spaces, except spaces which afford no substantial fire risk (such as, for example, void spaces and sanitary

spaces) shall be provided with an automatic fire suppression, fire detection, and fire alarm system of an Approved Type and complying with the requirements of SOLAS II-2 and the FSS Code, or an equivalent standard acceptable to the Administrator. The systems shall be designed to enable simultaneous operation of all sprinklers fitted in the most hydraulically demanding area. The minimum area for simultaneous operation may be taken as the largest area bounded by “A-0” class bulkheads or the breadth of the yacht squared, whichever is greater, subject to a maximum of 280 m².

- .2 Alternatives to §12.16.1 above that may be accepted as compliant by the Administrator include:
 - (a) In machinery spaces, water-mist fire extinguishing systems complying with the guidelines provided in IMO Circular [MSC/Circ.1165](#), *Revised Guidelines for the Approval of Equivalent Water-based Fire Extinguishing Systems for Machinery Spaces and Cargo Pump Rooms*, as amended⁸. See *Onboard Systems using Halogenated Hydrocarbons (Halons) and Other Ozone Depleting Substances (ODS)* ([MN 2-011-11](#)) for systems using halons.
 - (b) A manual dry pipe sprinkler system of an Approved Type either complying with the requirements of IMO Resolution [MSC.44\(65\)](#), *Standards for Fixed Sprinkler Systems for High Speed Craft*, or to an equivalent standard (to the satisfaction of the Administrator), which provides increased security against damage caused by accidental discharge from sprinklers. The system shall be installed and arranged to protect such spaces.

12.17 Fire Detection and Alarms

- .1 A fixed fire detection and fire alarm system of an Approved Type complying with the requirements of SOLAS II-2 and the FSS Code, shall be fitted in all enclosed spaces except those containing no significant fire risk (toilets, bathrooms, void spaces, etc.).
- .2 Manually operated call points complying with the requirements of SOLAS II-2 shall be installed.
- .3 At all times, yachts when at sea and in port (except when out of service) shall be manned and/or equipped to ensure that any initial fire alarm is immediately received by a responsible member of the crew.

⁸ Amended by IMO Circulars [MSC.1/Circ.1237](#), [MSC.1/Circ.1269](#), and [MSC.1/Circ.1386](#).

12.18 Public Address Systems

For yachts having a length of 85 m or more, a public address system complying with the requirements of SOLAS III/6.5 shall be available throughout the accommodation, service spaces, control stations, and open decks.

12.19 Lubricating Oil Arrangements

Arrangements for the storage, distribution, and utilization of oil used in pressure lubrication systems shall be such as to minimize the risk of fire or explosion.

12.20 Arrangements for Other Flammable Oils

Arrangements for the storage, distribution, and utilization of other flammable oils employed under pressure in power transmission systems, control and activating systems and heating systems shall be such as to minimize the risk of fire or explosion.

12.21 Prohibition of Carriage of Flammable Oils in Forepeak Tanks

Fuel oil, lubricating oil, and other flammable oils shall not be carried in forepeak tanks.

12.22 Arrangements for Gaseous Fuel for Domestic Purposes

Where gaseous fuel is used for domestic purposes the arrangements for the storage, distribution, and utilization of the fuel are to be such that, having regard to the hazards of fire and explosions which the use of such fuel may entail, the safety of the yacht and the persons on board is preserved. The installation is to be in accordance with recognized national or international standards and is to meet the requirements contained in §[10.1](#) above.

12.23 Space Heaters

Where space heaters are used, they shall be fixed in position and so constructed as to reduce their associated fire risks to a minimum. The design and location of these units is to be such that clothing, curtains, or other similar materials cannot be scorched or set on fire by heat from the unit.

12.24 Paints, Varnishes, and Other Finishes

Paints, varnishes, and other finishes which pose an undue fire hazard shall not be used in the engine room, galley, or in other areas of high fire risk. Elsewhere, such finishes shall be kept to a minimum.

12.25 Open Flame Gas Appliances and RFAs

- .1 An open flame gas appliance provided for cooking, heating, or any other purpose shall comply with the requirements of ISO 10239:2014 or an equivalent standard.
- .2 RFAs as defined in Chapter 1 shall meet the requirements of *Recreational Fire Appliances* ([MN 2-011-57](#)).

12.26 Arrangement of Fuel Oil Tanks and Piping

- .1 All yachts shall comply with SOLAS II-2/4.
- .2 Oil fuel tanks situated within, or adjacent to, the boundaries of Category A machinery spaces are not to contain oil fuel having a flashpoint of less than 60°C.

12.27 Emergency Escape Breathing Devices (EEBDs)

- .1 All yachts shall carry at least two EEBDs within the accommodation spaces and at least two shall be kept in each main vertical zone.
- .2 In the machinery spaces the EEBDs shall be situated for use in easily visible spaces which can be reached easily at any time in the event of a fire. The location of EEBDs shall take into account the layout of the machinery space and the number of persons normally working in the machinery space.
- .3 The number and location of these devices shall be indicated in the Fire Control Plan.
- .4 EEBDs shall comply with the FSS Code.

13.0 MACHINERY FOR YACHTS OF LESS THAN 500 GT

13.1 General Requirements

- .1 The machinery and its installation shall be approved and installed in accordance with the Rules of Class.
- .2 Where a yacht operates with periodically unattended machinery spaces, the machinery shall be approved and installed in accordance with the Rules of Class and shall also meet the requirements of SOLAS II-1/E to the extent that is reasonable and practicable.
- .3 Plastic piping may be accepted where the piping and the arrangements for its use meet the requirements of the 2010 FTP Code.

- .4 The requirements for main propulsion are based upon the installation of diesel powered units burning distillate fuels which are not required to be heated. When other types of main propulsion systems are proposed, the arrangements and installation may be considered by the Administrator.
- .5 Where gas turbines are to be fitted, reference should be made to Chapter 9.3 of the International Code of Safety for High-Speed Craft (HSC 2000 Code), which shall be used as guidance for installation requirements. The installation shall be to the satisfaction of the RO.

13.2 Installation

- .1 Notwithstanding the requirements referred to in §13.1 above, the machinery, fuel tanks, and associated piping systems and fittings shall be of a design and construction adequate for the service for which they are intended.
- .2 The machinery, fuel tanks, and associated piping systems and fittings shall be installed and protected so as to reduce to a minimum any danger to persons during normal movement about the yacht; due regard shall be made to moving parts, hot surfaces, and other hazards.
- .3 Means shall be provided to isolate any source of fuel that may feed a fire in an engine space. Fuel shut-off valves shall be capable of being closed from a position outside the engine space. The valve(s) shall be fitted as close as possible to the fuel tank(s).
- .4 When a glass fuel level gauge is fitted, it shall be of the “flat glass” type with self-closing valves between the gauge and the tank.
- .5 Notwithstanding the requirements of §13.1 above, in a fuel supply system to an engine unit, when a flexible section of piping is installed connections shall be of a screw type or an equivalent Approved Type. Flexible pipes shall be fire resistant or metal reinforced or otherwise protected from fire.
- .6 All fuel lines are to be properly supported by suitable brackets to the satisfaction of the Administrator or its representative. Materials and fittings shall be of a suitable recognized national or international standard that provides for a fire rating of at least 800°C for 30 minutes.
- .7 Steel filter bowls are required; glass or plastic filter bowls are not acceptable.
- .8 External high-pressure fuel delivery pipes between the high pressure fuel pumps and fuel nozzles are to be protected with approved jacketed tubing capable of containing fuel spills in case of a fuel line failure. Means for the collection of fuel, including alarm arrangements, shall be provided in the event of a fuel line failure.

- .9 Fuel oil lines shall not be located immediately above or near units of high temperature including exhaust manifolds, silencers, or other equipment required to be insulated. Fuel oil lines shall be arranged far apart from hot surfaces, electrical installations, or other sources of ignition.
- .10 Fuel oil line joints shall be protected (anti-splash tape or equivalent) to avoid spraying or leaking onto a source of ignition.
- .11 Multi-engine installations which are supplied from one common fuel source shall be provided with means of isolating the fuel supply to the individual engines. The means of isolation shall not affect the operation of the other engine(s) and shall be operable from a position which would not be rendered inaccessible by a fire or spill on any of the engines.
- .12 Machinery exhaust systems shall not normally pass through any accommodation sections unless they are fitted in a gas tight trunk or each space is fitted with a carbon monoxide detector where the alarm is to be provided locally and at a continuously manned station.

13.3 Steering Gear

13.3.1 Steering Systems

- .1 The steering gear shall be capable of turning 35° from one side to 35° on the other side at the maximum ahead service speed of the yacht and, under the same conditions, 35° from one side to 30° on the other side in not more than 28 seconds.
- .2 Where the main steering gear comprises two or more identical power units, the conditions of §13.3.1.1 shall apply for each single unit.
- .3 When appropriate to the safe steering of the yacht, the steering gear shall be power operated.

13.3.2 Emergency Steering

In the event of failure to the main steering system, means for emergency steering shall be provided.

13.4 Bilge Pumping Arrangements

13.4.1 Pumps

- .1 All yachts shall be equipped with at least two fixed and independently powered pumps, with suction pipes so arranged that any compartment can be effectively drained when the yacht is heeled to an angle of up to 10° under all practical circumstances.

- .2 The location of pumps and their individual power supplies and controls, including those for bilge valves, shall be such that in the event of any one compartment being flooded another pump is available to control progressive flooding to other compartments.
- .3 Each bilge pump suction line, other than the emergency suction line, shall be fitted with an efficient strum box or strainer.
- .4 Portable semi-submersible bilge pumps, preferably diesel driven, may be considered by the Administrator or its representative as an alternative to one of the two required pumps.

13.4.2 Periodically Unmanned Machinery Spaces

In the case of a yacht where the propulsion machinery space may be unmanned at any time, a bilge level alarm shall be fitted. The alarm shall be able to provide an audible and visual warning in the crew mess and in the wheelhouse. The location of the audible and visual alarm may be approved by the Administrator elsewhere on the yacht if it is considered that such a location may be more practical.

13.4.3 Pumping and Piping Arrangements

- .1 Pumping and piping arrangements for bilges into which fuel or other oils of similar or higher fire risk could collect, under either normal or fault conditions, shall be kept clear of accommodation spaces and separate from accommodation bilge systems. Bilge level alarms which meet the requirements of §13.4.2 above shall be fitted to all such bilges in spaces that are unmanned at any time.
- .2 Approved plastic bilge piping may be accepted outside the engine room. The materials used for bilge piping in the engine room shall meet the fire resistant requirements of a Classification Society.
- .3 All distribution boxes and manually operated valves in connection with the bilge pumping arrangements shall be in positions which are accessible under ordinary circumstances.
- .4 It shall be ensured that satisfactory emergency bilge pumping (independent of the main bilge pumps) is provided.
- .5 The bilge system shall be designed to ensure that there is no direct uncontrolled discharge of bilge water into the marine environment. Emergency bilge discharge valves and other overboard discharge valves of a similar nature that are normally closed shall be sealed in the closed position with numbered seals. The mini-ISM shall implement a suitable method, either manual or electronic, for recording the changes in the process, including removal and replacement of numbered seal tags,

testing of valves, maintenance, and other operational requirements. In accordance with IMO Circular [MSC-MEPC.1/Circ.3](#), *Blanking of Bilge Discharge Piping Systems in Port*, the sealing of valves of an emergency nature shall not be construed as a requirement for the valve to be blanked or physically locked. It shall be ensured that such valves remain available for use at all times in case of an emergency situation, and valve sealing may be accomplished through use of a breakable seal, electronic tracking, or similar method.

- .6 Yachts of less than 400 GT shall be equipped, as far as practicable, to retain oil or oily mixtures on board and/or discharge them in accordance with the requirements of MARPOL Annex I.
- .7 Yachts of 400 GT and above shall fully comply with the regulations of MARPOL Annex I, except as specified otherwise in the Annex. For further guidance, refer to *MARPOL Standard Discharge Connectors on Yachts* ([TC 5](#)).
- .8 Special consideration shall be given to *Oil Filtering Equipment and Control of Operational Discharge of Oil* ([MN 2-013-3](#)).

13.5 Electrical Installations

13.5.1 Installation

- .1 Overload and short circuit protection of all circuits shall be provided, except engine starting circuits supplied from batteries.
- .2 Lighting circuits, including emergency circuits, shall be distributed through all spaces and in such a manner that a total blackout cannot occur due to the tripping of a single protective device.
- .3 Electrical devices working in potentially hazardous areas, into which petroleum vapor or other hydrocarbon gas may leak, shall be provided with protection against the risk of igniting the gas. Reference should be made to [§10.1](#) above.
- .4 Exposed metal, such as casings, of electrical machines and equipment, which are not intended under normal conditions to conduct electricity, but are liable under fault conditions to do so, shall be earthed unless the machines or equipment are:
 - (a) supplied at a voltage not exceeding 50 volts (V) direct current or 50 V root mean square between conductors (auto-transformers shall not be used for the purpose of achieving this voltage); or
 - (b) supplied at a voltage not exceeding 250 V by safety isolating transformers supplying only one consuming device; or
 - (c) constructed in accordance with the principle of double insulation.

- .5 When a distribution system with no connection to earth is used for power, heating, or lighting, whether it is main or emergency, a device capable of indicating an abnormally low insulation value shall be provided.
- .6 Where a risk of lightning strike is identified, reference shall be made to ISO 10134:2003, “Small craft - electrical devices - lightning protection systems,” and the proper protection provided.
- .7 Electric cables and wiring external to equipment shall be at least of a flame-retardant type and shall be so installed as not to impair their original flame-retarding properties. The Administrator may permit the use of special types of cables, such as radio frequency cables, which do not comply with this requirement. Further:
 - (a) electric cables and wiring serving essential or emergency power, lighting, internal communications, or signals shall so far as is practicable be routed clear of galleys, laundries, machinery spaces of Category A and their casings, and other high fire risk areas; and
 - (b) electric cables connecting fire pumps to the emergency switchboard shall be of a fire-resistant type where they pass through high fire risk areas. Where practicable, all such cables shall be run in such a manner as to preclude their being rendered unserviceable by heating of the bulkheads that may be caused by a fire in an adjacent space.
- .8 Electric cables and wiring shall be installed and supported in such a manner as to avoid chafing and other damage.

13.5.2 Emergency Sources of Power

- .1 An emergency source of electrical power shall be provided on board the yacht.
- .2 The electrical power, associated transforming equipment (if any), means to transfer power and the emergency switchboard shall be located above the uppermost continuous deck and shall be readily accessible from the open deck.
 - (a) The Administrator may consider alternative arrangements for the location of the emergency source of electrical power as long as the location is protected from fire and flooding; however, it shall never be forward of the collision bulkhead. The electrical emergency switchboards shall in all cases be located above the uppermost continuous deck.

- (b) When an emergency generator is provided, the alternative location must be readily accessible from an open deck and separated (in accordance with Table 8 provided in §11.1.5 above) from the main engines and main switchboards to ensure continued operation. The emergency generator shall be self-contained.
- .3 Emergency electrical power shall be sufficient to provide power for three hours duration at maximum output which includes powering all of the following:
- (a) power supply to navigation lights;
 - (b) VHF radio;
 - (c) ship earth radio station;
 - (d) medium frequency (MF) or MF/high frequency (HF) radio (if installed);
 - (e) internal communication equipment required in an emergency;
 - (f) fire detection alarm system and fire door holding and release system;
 - (g) intermittent operation signaling lamp, ships whistle, and manually operated call points;
 - (h) all internal signals required in an emergency;
 - (i) one fire pump; and
 - (j) one bilge pump.
- .4 Emergency electrical power shall be sufficient for a period of 30 minutes if any of the following are installed:
- (a) watertight doors; or
 - (b) emergency arrangements to bring the elevator (lift) to deck level for escape.

13.5.3 Emergency Lighting

An emergency source of lighting shall be provided which shall be independent of the general lighting system and sufficient to enable persons to make their way from the accommodations or working spaces up to the open deck and evacuate the yacht, if

necessary. This lighting, supplemented by flashlights, shall also be sufficient to permit emergency repairs.

13.5.4 Batteries

- .1 Batteries shall be of a type suitable for marine use and not susceptible to leakage.
- .2 Batteries shall be suitably stored, secured, and sea fastened.
- .3 In areas where batteries are stored, adequate ventilation shall be provided to prevent an accumulation of gas that may be emitted.
- .4 In areas where unsealed batteries are stored, personal protective equipment shall consist, at a minimum, of protective gloves, fully closed goggles or face mask, eye wash, and an apron.
- .5 Particular caution, with respect to fire hazards, should be taken when using portable electronic devices powered by lithium-ion batteries.

13.5.5 Battery Systems for (Hybrid) Propulsion

Where batteries are used for propulsion or electric power supply during ship operations, the battery system design, operation, and spaces containing these systems shall be designed, installed, and approved in accordance with the rules of a Classification Society.

14.0 MACHINERY FOR YACHTS 500 GT AND ABOVE

14.1 General Requirements

- .1 Machinery shall be approved and installed in accordance with the Rules of Class as well as SOLAS II-1/C and any other applicable international conventions.
- .2 For yachts that operate with periodically unattended machinery spaces, the machinery shall be approved and installed in accordance with the Rules of Class and shall also meet the requirements of SOLAS II-1/E to the extent that is reasonable and practicable.
- .3 Where gas turbines are to be fitted, reference should be made to Chapter 9.3 of the HSC 2000 Code, which shall be used as guidance for installation requirements. The installation shall be to the satisfaction of the RO.
- .4 Machinery exhaust systems shall not normally pass through any accommodation spaces unless they are fitted in a gas tight trunk or each space is fitted with a

carbon monoxide detector where the alarm is to be provided locally and at a continuously manned station.

14.2 **Main Steering Gear**

The rudder, steering gear, and its installation shall meet the requirements of a Classification Society and the standards of SOLAS II-1.

14.3 **Bilge Pumping Arrangements**

- .1 The bilge pumping arrangements and installation shall meet the requirements of a Classification Society and SOLAS II-1. The bilge system shall be designed to ensure that there is no direct uncontrolled discharge of bilge water into the marine environment. Special consideration shall be given to *Oil Filtering Equipment and Control of Operational Discharge of Oil* ([MN 2-013-3](#)). For further guidance, refer to the Technical Circular addressing the *MARPOL Standard Discharge Connectors on Yachts* ([TC 5](#)).
- .2 Emergency bilge discharge valves and other overboard discharge valves of a similar nature that are normally closed shall be sealed in the closed position with numbered seals. The SMS should implement a suitable method, either manual or electronic, for recording the changes in the process, including removal and replacement of numbered seal tags, testing of valves, maintenance, and other operational requirements. In accordance with IMO Circular [MSC-MEPC.1/Circ.3](#), *Blanking of Bilge Discharge Piping Systems in Port*, the sealing of valves of an emergency nature shall not be construed as a requirement for the valve to be blanked or physically locked. It shall be ensured that such valves remain available for use at all times in case of an emergency situation, and valve sealing may be accomplished through use of a breakable seal, electronic tracking, or similar method.

14.4 **Electrical Installation**

- .1 The electrical installation and its appliances shall meet the requirements of a Classification Society and SOLAS II-1/Part D.
- .2 The location of the emergency generator, its associated equipment and switchboards shall meet the requirements of SOLAS II-1 as applicable.
- .3 The Administrator may consider alternative arrangements for the location of the emergency source of power as long as the location is protected from fire and flooding; however, it shall never be forward of the collision bulkhead. The electrical emergency switchboards shall in all cases be located above the uppermost continuous deck.

14.5 Battery Systems for (Hybrid) Propulsion

Where batteries are used for propulsion or electric power supply during ship operations, the battery system design, operation, and spaces containing these systems shall be designed, installed, and approved in accordance with the rules of a Classification Society.

15.0 FIRE-FIGHTING EQUIPMENT - YACHTS OF LESS THAN 500 GT

15.1 General Requirements

- .1 Fire appliances shall be of an Approved Type and shall be to the satisfaction of the Administrator or its authorized representative.
- .2 Any fire appliances provided in addition to those required by this section shall also be of an Approved Type.
- .3 The location, installation, testing, and maintenance of all equipment shall be to the satisfaction of the Administrator and in accordance with *Maintenance and Inspection of Fire Protection Systems and Appliances* ([MN 2-011-14](#)).
- .4 The location of concealed fire appliances shall be clearly marked; however, the marking need not comply with IMO signs, but must be suitably positioned and visible to identify the location of the fire-fighting equipment.

15.2 Specific Requirements

15.2.1 Fire Pumps

- .1 At least two fire pumps shall be provided on board a yacht; one of which must be an independent power-driven pump.
- .2 The power-driven fire pump shall have a capacity of:

$$2.5 \times (1 + 0.066 \times (L(B+D))^{0.5})^2 \text{ m}^3/\text{hour}$$

Where:

L is the Load Line Length;

B is the greatest moulded breadth; and

D is the moulded depth measured to the bulkhead deck at amidships.

- .3 The pump shall, when discharging at full capacity through any two fire hydrants, be capable of maintaining a pressure of 0.2 newton per square mm (N/mm²) at each hydrant so long as the fire hose can be effectively controlled at this pressure.

- .4 The second fire pump, if not meeting the requirements of §15.2.1.2 above, shall have the capacity of at least 80% of that required in §15.2.1.2 above, and may be:
 - (a) a portable fire pump with a permanent sea connection external to the machinery space and having the ability to feed the fire main; or
 - (b) a bilge pump that can be, by means of valves, connected to the fire main.
- .5 Each centrifugal pump shall be provided with a non-return check valve in the connection to the fire main.

15.2.2 Fire Main and Hydrants

- .1 A fire main with connected fire hydrants shall be fitted to the yacht.
- .2 The fire main and hydrants shall be so arranged that, if necessary, one length of hose can be used to provide one stream of water to any location on board that is normally accessible to the passengers or crew, including any store room or storage compartment.

The fire main and hydrants shall be arranged to avoid being readily damaged.
- .3 The fire main and all connections to the hydrants shall have an inner diameter and schedule that is appropriately sized for the maximum discharge rating of the pump(s) connected as specified by the manufacturer.
- .4 The fire main and hydrants shall be made of materials that:
 - (a) are not readily rendered ineffective by heat unless adequately protected; and
 - (b) do not readily corrode.
- .5 The fire main and hydrants shall be so arranged to avoid the possibility of freezing.
- .6 Where the second fire pump is fitted in a different location than the primary pump (e.g., outside of the machinery space) isolating valves that separate the section of the fire main within the machinery space containing the primary fire pump(s) from the rest of the fire main shall be fitted so that the secondary pump may feed the fire main separately from any piping positioned within the machinery space.
 - (a) The isolating valves shall be of a manually operated type fitted in an easily accessible location outside of the machinery space.
 - (b) If any part of the isolated section of the fire main must pass through the machinery space it shall be insulated to “A-60.”

- .7 An isolating valve shall be fitted to each hydrant so that any hose may be removed while the fire pumps are in operation without losing pressure.
- .8 At a minimum, at least two separate hydrants shall be provided in locations where if one is rendered inaccessible the other is likely to remain free of debris, water, fire, or other hindrance.
- .9 The fire main shall have no connection(s) or permanent function(s) other than for fire-fighting or anchor wash down.
- .10 Where a classed yacht has a class notation indicating a periodically unattended machinery space or where only one person is required on watch, there shall be the ability to remotely start the fire pumps from the navigating bridge and fire control station.
- .11 If the fire control station is positioned at a location less than two compartments removed or 10 m, whichever is less, from the navigating bridge the remote start need only be provided at one of the locations.

15.2.3 Fire Hoses and Nozzles

- .1 Fire hoses shall be of an Approved Type and be provided with similarly approved nozzles and couplings.
- .2 Fire hoses, nozzles, and other associated tools and fittings shall be kept in readily accessible and marked locations close to the hydrants or connections on which they will be used.
- .3 In interior spaces, hydrants, nozzles, and any other associated connections necessary for fire-fighting shall be connected and readily accessible at all times.
- .4 Fire hoses shall not exceed 20 m in length and the diameter of a lined hose for use with a power-driven pump shall not be less than 38 mm.
- .5 Jet or spray nozzles shall have a diameter of 19 mm, 16 mm, or 12 mm depending on fire-fighting purposes and shall have the ability to be opened and closed.

For accommodation and service spaces, the diameter of nozzles need not exceed 12 mm.
- .6 Smaller diameter hoses and jet/spray nozzles will be considered as meeting the requirements of this Code as long as they will not negatively impact the fire-fighting ability of the system, as designed.
- .7 The number of fire hoses and nozzles provided shall correspond to the specific and unique requirements of the yacht; but in no case shall there be less than three fire hoses and nozzles on each yacht.

15.2.4 Portable Fire Extinguishers for Use in the Accommodation and Service Spaces

- .1 The number, location, capacity, and fire extinguishing medium type shall be selected in accordance with the specific and unique requirements of the yacht, but in no case shall there be less than three fire extinguishing mediums on each yacht.

The fire extinguishers provided shall have, as far as is reasonable and practicable, a uniform method of operation and shall be of an approved 5 kilograms (kg)/9 L type and capacity.

For each deck there shall be at least one portable extinguisher available within a maximum distance of 10 m from any location. The extinguisher shall be within the same fire zone or watertight subdivision.

- .2 Carbon dioxide portable fire extinguishers shall not be located or provided for use in accommodation spaces.
- .3 In locations containing electrical or electronic equipment, batteries, and/or appliances necessary for the safe operation of the yacht, fire extinguishers of a medium that is neither electrically conductive nor harmful to the equipment and/or appliances shall be installed. In locations where lithium-ion or other rechargeable batteries are stowed, the type of fire extinguishing medium shall specifically be considered for effectiveness.
- .4 Fire extinguishers shall be located external to but adjacent to the entrance of the space for which they are intended to be used. Additionally, they shall be in a marked and easily visible location which is easily accessible in an emergency and where damage cannot readily occur.
- .5 Spare charges shall be provided on board for 100% of the first four portable fire extinguishers and at least 50% of each type and capacity of the remaining portable fire extinguishers capable of being recharged on board.
- .6 When the extinguishers cannot be recharged onboard, additional spare extinguishers shall be provided in the same quantities as required by §15.2.4.5 above.

15.2.5 Fire Extinguishing in Machinery Spaces

- .1 Category A machinery spaces containing internal combustion type machinery shall be provided with:
 - (a) a fixed fire extinguishing system approved in accordance with the FSS Code; and
 - (b) one portable fire extinguisher for oil fires for each 75 kW (100 horsepower), but no more than seven extinguishers are required; or

- (c) two portable fire extinguishers for oil fires together with:
 - (i) one foam extinguisher of 45 L capacity; or
 - (ii) one carbon dioxide portable fire extinguisher of 16 kg capacity. In lieu of one such extinguisher, in small engine rooms, two 9 kg portable extinguishers may be accepted by the RO.
- .2 In a machinery space containing an oil fuel settling tank, oil fuel unit, oil fired boiler or incinerator, a fixed fire extinguishing system complying with the standards as found in the FSS Code shall be provided.
- .3 In addition to that which is specified in §15.2.5.1 above, the number, location, capacity, and fire extinguishing medium type shall be selected in accordance with the specific and unique requirements of the yacht, but in no case less than two for any individual machinery space containing any part of an oil fuel installation.
- .4 Additionally, one portable fire extinguisher shall be readily accessible for use in the steering gear compartment.

15.2.6 Additional Fire Appliances

The following additional appliances are required:

- (a) two fireman's outfits including an approved breathing apparatus for each outfit. The fireman's outfit shall meet the requirements of SOLAS II-2, including the carriage of spare bottles for the Self-Contained Breathing Apparatus (SCBA); and
- (b) one fire blanket in the galley and other areas where cooking may occur.

16.0 FIRE-FIGHTING EQUIPMENT - COMMERCIAL YACHTS 500 GT AND ABOVE

- .1 Yachts of 500 GT and above shall comply with SOLAS II-2. If, depending on the design of the yacht and its equipment, the SOLAS requirements cannot be practically met, compliance with other standards, such as those found in §[15.0](#) above, may be considered by the Administrator.
- .2 Concealed fire-fighting equipment shall be clearly marked; however, the marking need not comply with IMO signs, but must be suitably positioned and visible to identify the location of the fire-fighting equipment.
- .3 Yachts of 500 GT and above shall be provided with at least one international shore connection complying with the FSS Code.

- .4 The location, installation, testing, and maintenance of all equipment shall be to the satisfaction of the Administrator and in accordance with *Maintenance and Inspection of Fire Protection Systems and Appliances* ([MN 2-011-14](#)).

17.0 LIFE-SAVING APPLIANCES

17.1 General Requirements

17.1.1 Life-Saving Appliances

- .1 All yachts shall be provided with life-saving appliances in accordance with the Life-Saving Appliances Table 13 in this section.
- .2 All yachts shall be provided with an approved life-saving appliances general arrangement plan (normally combined with the fire control general arrangement plan). Symbols used on the plan(s) shall comply with *Fire Control Plans, Escape Route Signs, and Life-Saving Symbols* ([MN 2-011-10](#)).
- .3 All equipment fitted shall be of an Approved Type that is in accordance with *Life-saving Appliances and Systems* ([MN 2-011-37](#)). Unless expressly provided otherwise, all life-saving appliances shall comply with the LSA Code and IMO Resolution [MSC.81\(70\)](#), *Revised Recommendation on Testing of Life-saving Appliances*, as amended⁹.
- .4 Life-saving appliances and associated equipment shall be serviced at the intervals specified in MN 2-011-37. Approved disposable hydrostatic release units which have been approved for a service life of more than one year, need not be serviced annually, but shall be replaced at the end of their service life in accordance with the manufacturer's recommendations.
- .5 Maintenance of life-saving equipment shall be carried out in accordance with the instructions for onboard maintenance. See [§27.5](#) of this Chapter.
- .6 A yacht which is fitted with a Marine Evacuation System (MES) shall in addition to above section §17.1.1.4 regarding servicing and inspection, have each MES deployed from the yacht on a rotational basis at intervals agreed with the Administrator and in accordance with the manufacturer's instructions, provided that each individual system is deployed at least once every six years.
- .7 All life-saving equipment that may be provided, either mandatorily or voluntarily, must meet the requirements of this [§17.1](#).

⁹ Amended by IMO Resolutions [MSC.200\(80\)](#), [MSC.226\(82\)](#), [MSC.274\(85\)](#), [MSC.295\(87\)](#), [MSC.321\(89\)](#), [MSC.323\(89\)](#), [MSC.378\(93\)](#), [MSC.427\(98\)](#), and [MSC.472\(101\)](#).

When safety equipment is provided for use in supplementary activities, such as water sports, or used for training purposes, arrangements for its stowage and its marking shall ensure that it will not be mistakenly used as approved life-saving equipment in an emergency situation.

- .8 All life-saving equipment carried on board shall be fitted with retro-reflective material in accordance with the recommendations found in IMO Resolution [A.658\(16\)](#), *Use and Fitting of Retro-Reflective Materials on Life-Saving Appliances*. Retro-reflective material already fitted on existing life-saving appliances in accordance with IMO Resolution [A.274\(VIII\)](#), *Recommendation on Retro-Reflective Tapes on Life-Saving Appliances*, will continue to be accepted until it has to be replaced as a result of deterioration or damage.
- .9 The stowage and installation of all life-saving appliances is to be to the satisfaction of the Administrator or its representative, as applicable.
- .10 All life-saving appliances shall be kept in good condition and be ready for immediate use before any voyage is commenced and at all times during the voyage.
- .11 In the case of an emergency that necessitates the safe evacuation of the yacht, special consideration shall be given, and provisions made as necessary, to avoid interference from dangerous elements, above or below the waterline, such as, propellers, impellers, stabilizers, sea chests, bow thrusters, etc.
- .12 Means shall be provided to prevent overboard discharge of water into survival craft during abandonment.

Table 13
Life-Saving Appliances (see sections of this Chapter as noted below)

Size of Yacht	<500 GT			≥500 GT	≥85 M
	2	1	0	All	
Life Boats (see §17.2.1)	No				Yes
Life Rafts (see §17.2.2)	Yes				
Rescue Boat (see §17.2.4)	No	Yes			
Recovery of Persons from the Sea (see §17.2.3)	Yes				
Lifejackets (see §17.2.6)	Yes				
Immersion Suits (see §17.2.7)	Yes				
Life Buoys (Total) (see §17.2.5)	Four	Six	Eight		
Life Buoys with Light and Smoke; or SOLAS-Approved Strobe (see §17.2.5.4)	Two				

Table 13
Life-Saving Appliances (see sections of this Chapter as noted below)

Size of Yacht	<500 GT			≥500 GT	≥85 M
Category	2	1	0	All	
Life Buoys with Buoyant Line (see §17.2.5.3)	Two				
Line Throwing Appliances with Spare Charge(s) (see §17.2.9)	One				
Rocket Parachute Flares (see §17.2.8)	Four		Six	Twelve	
Red Hand Flares (see §17.2.8)	Six	Twelve			
Smoke Signals (see §17.2.8)	Two			Four	
Portable VHF	Two	Three			
EPIRBs (see §17.2.10)	One				
SARTs (see §17.2.11)	One	Two			
General Alarm (see §17.2.12)	Yes				
Posters / Signs / Placards Showing Survival Craft and Equipment Operating Instructions	Yes				
Training Manual (see §27.4)	Yes				
Mini-ISM (see Annex 1)	Yes			No	
ISM Code	Voluntary Compliance			Yes	
Life-Saving Signals and Rescue Poster (see §17.2.14)	Yes				

17.1.2 Launching Appliances

- .1 Launching appliances shall be in accordance with the LSA Code, unless expressly provided otherwise in this Code.
- .2 Any inspection, servicing, or repair of cranes, wires, and associated parts of the launching appliances shall be carried out in accordance with *Life-Saving Appliances and Systems* ([MN 2-011-37](#)) and services developed by the manufacturer.
- .3 Falls for launching devices must comply to the requirements of the LSA Code. When fibre rope falls are fitted, these shall meet the requirements of *Use and Maintenance of Non-Steel Wires/Falls on Yachts for Lifeboat/Rescue Boat/LifeRaft Davits* ([MN 2-011-50](#)). Falls of other materials (ie. stainless steel) may be considered by the Administrator on a case-by-case basis.

17.2 Equipment Carriage Requirements

17.2.1 Lifeboats

- .1 Lifeboats are required on yachts of 85 m or more in length.
- .2 When lifeboats are required to be carried, their acceptance is conditional upon suitable stowage and launching arrangements.
- .3 When lifeboats are provided on each side of the yacht, each lifeboat shall be of sufficient capacity to accommodate the total number of persons on board.
- .4 Where it is considered impractical to carry lifeboats, the Administrator may approve alternative arrangements which may include, but not necessarily be limited to:
 - (a) the substituting of life rafts if the required subdivision index meets the requirements of a SOLAS 2-compartment subdivision standard; or
 - (b) the fitting of a sufficient number of davit launched life rafts, so long as the aggregate capacity on each side of the yacht is such that if any one life raft is lost, damaged, or otherwise rendered unusable there remains the capacity for 100% of the persons on board. Additionally, one approved rescue boat shall be provided on each side of the yacht; or
 - (c) the installation of an approved MES which:
 - (i) including its installation, is in accordance with SOLAS III and the LSA Code and shall be to the satisfaction of the RO;
 - (ii) in the event of any one MES being lost or rendered unserviceable, provides sufficient aggregate life raft capacity remains on either side of the yacht to accommodate all persons on board;
 - (iii) provides an alternative means of evacuating passengers and crew into survival craft on the same side of the craft in unfavorable conditions; and
 - (iv) provides one approved rescue boat on each side of the yacht.
- .5 A lifeboat will also be acceptable as a rescue boat provided it meets the requirements for an approved rescue boat as indicated in §[17.2.4](#) below.

17.2.2 Life Rafts

- .1 Life raft embarkation arrangements shall comply with the following:
 - (a) A means of embarkation of life rafts must be provided where the distance between the embarkation deck and the top of the life raft buoyancy tube exceeds 1 m when the yacht is in its lightest condition.
 - (b) Where the distance between the embarkation deck and the top of the life raft buoyancy tube exceeds 4.5 m when the yacht is in its lightest condition, davit launched life rafts shall be provided with at least one launching appliance also provided on each side of the yacht.
 - (c) A life raft will be considered as being readily transferable if it is able to be carried by two persons and can be launched within five minutes from its stowed location.
 - (d) The readily transfer ability of life rafts shall be demonstrated to the satisfaction of the RO.
- .2 The life rafts carried are to be stowed in Glass Reinforced Plastic (GRP) containers and must contain the necessary SOLAS emergency pack, the contents of which are dependent upon the yacht's limiting Category:
 - (a) yachts in Category 2 must have life rafts equipped with a SOLAS B Pack; and
 - (b) yachts in Category 0 or 1 must have life rafts equipped with a SOLAS A Pack.
- .3 The life rafts carried on board the yacht shall each be of equal capacity or as near equal as possible.
- .4 Life raft approval includes approval of their stowage, launching, and float-free arrangements.
- .5 A yacht shall be provided with life rafts of such number and capacity that, in the event of any one life raft being lost, damaged, or otherwise rendered unusable there remains sufficient capacity for all persons on board.
- .6 For a yacht of less than 85 m in length, one or more life rafts are to be provided on each side of the yacht of sufficient aggregate capacity to accommodate the total number of persons on board. Life rafts are to be readily transferable for launching on either side of the yacht.

If life rafts are not readily transferable, additional life rafts shall be fitted so that life rafts having a total capacity of 150% of the yacht's complement are provided on each side of the yacht.

- .7 Life rafts, other than davit launched life rafts, shall be capable of launching from their stowed location and upon release, fall clear of any obstructions, superstructures, or hull with the vessel in an upright condition. Consideration shall be given to mitigate the risk of life rafts being trapped into recessed side decks or other structural features when the yacht is in a heeled condition.
- .8 In lieu of meeting the requirements of §17.2.2.6 above yachts limited to Category 2 of less than 500 GT may carry a sufficient number of life rafts, so that in the event of any one life raft being lost or rendered unserviceable, sufficient aggregate capacity remains on either side of the yacht for all persons on board. This may be achieved by transferring life rafts from one side to the other.
- .9 For a sailing yacht, when it is impractical to stow the life rafts required by §17.2.2.6 above at the yacht's side, alternative arrangements may be accepted to provide life rafts having a capacity of 150% of the yacht's complement stowed on the centerline, subject to their being readily transferable to either side of the yacht.
- .10 When lifeboats are provided in accordance with §17.2.1.3 above, sufficient life rafts are to be fitted on each side of the yacht capable of accommodating 50% of the total number of persons on board. Life rafts are to be readily transferable for launching on either side of the yacht.

If life rafts are not readily transferable, additional life rafts having a total capacity of 100% of the yacht's complement shall be provided on each side of the yacht.

17.2.3 Recovery of Persons from the Sea

- .1 Means shall be provided for the recovery of a person from the sea to the yacht. If a person is unconscious or unable to assist in the rescue, means shall be provided to recover them. This may be satisfied by an inflatable boat or rescue boat provided with a suitable davit should it not be possible for the yacht itself to be used to recover persons from the sea.
- .2 All yachts shall have yacht-specific plans and procedures for the recovery of persons from the water. The plans shall identify the equipment intended to be used for recovery purposes and measures to be taken to minimize the risk to shipboard personnel involved in recovery operations, in accordance with *Plans and Procedures to Recover Persons from the Water* ([MN 2-011-47](#)).
- .3 The means of recovery shall be demonstrated to the satisfaction of the ROs requested.

- .4 If an over side boarding ladder or scrambling net is provided to assist in the recovery of an unconscious person from the water, the ladder or net shall extend from the weather deck to at least 600 mm below the lowest operational waterline.

17.2.4 Rescue Boats

- .1 Unless specified otherwise in this section, all rescue boats and associated equipment covered in this section shall comply with the LSA Code.
- .2 Launching of a rescue boat shall always be designed to allow it to be launched from a sheer vertical side of the yacht as far as is practical and in an area free of impedances or hazards in accordance with §[17.1.1.11](#) and §[17.1.1.12](#). The rescue boat need only be able to be launched from one side of the yacht.
- .3 If the rescue boat is stowed forward, the launching appliances shall be entirely located in a position aft of the vertical extension of the aft most portion of the collision bulkhead.
- .4 The requirements of §17.2.3 above shall also be followed.
- .5 Yachts of 500 GT and above:
 - (a) A rescue boat and associated equipment which complies with SOLAS III and the LSA Code shall be provided; however, it may be of any color, but must be capable of displaying a highly visible color.
 - (b) The acceptance of an approved rescue boat is conditional upon the provision of suitable stowage and launching arrangements. The launching arrangements shall be of an Approved Type and/or acceptable to the Administrator. When a power-operated crane is used as a launching device, it shall be capable of operation by hand in the event of a power failure. A secondary power source, e.g., emergency generator power, battery, or hydraulic pump is acceptable in lieu of emergency hand operation of the rescue boat crane.
 - (c) An inflatable or rigid inflatable rescue boat may be accepted; however, it must be in a fully inflated condition at all times.
 - (d) Launching appliances shall be in accordance with §[17.1.2](#) above.
- .6 Yachts of less than 500 GT:
 - (a) Yachts of Category 0 or 1 shall comply with the requirements of §17.2.4.5 above or the following:

- (i) a boat that is suitable for rescue purposes is carried on board but which is of a non-SOLAS Approved Type. In this case, the boat shall have capacity for not less than four persons, one of which should be assumed to be lying down. The boat may be a rigid, rigid inflatable, or inflatable tender of any color, but must be capable of displaying a highly visible color. Tubes of non-SOLAS inflatable boats shall have a minimum of three buoyancy compartments built in; and
 - (ii) the launching appliances shall be capable of launching the boat within five minutes. When a power-operated crane is used as a launching device, it shall be capable of operation by hand in the event of a power failure. A secondary power source, e.g., emergency generator power, battery, or hydraulic pump is acceptable in lieu of emergency hand operation of the rescue boat crane; and
 - (iii) launching appliances and associated equipment shall be constructed to withstand a static load test of not less than 2.2 times the maximum working load. Acceptable factors of safety for wires, sheaves, and hooks shall not be less than 6, and for the remainder of the launching appliances, not less than 4.5. In addition, the launching appliances and associated equipment shall also be tested dynamically to 1.1 times the working load.
- (b) For yachts of Category 2, if a rescue boat complying with §17.2.4.1 to §17.2.4.6 above is not carried on board, alternative arrangements may be considered to the satisfaction of the RO, including:
- (i) a rescue boat of a SOLAS Approved Type which is towed by the yacht; or
 - (ii) a rescue boat which is stowed in the lazarette or garage, provided that it can be launched in a reasonable time frame and there is the ability to efficiently use the yacht itself to recover an unconscious person from the water; or
 - (iii) a boat that is suitable for rescue purposes is carried on board but which is of a non-SOLAS Approved Type. In this case, the boat shall have a capacity for not less than four persons, one of which should be assumed to be lying down. The boat may be a rigid, rigid inflatable, or inflatable tender and be capable of displaying a highly visible color. Tubes of non-SOLAS inflatable boats shall have a minimum of three buoyancy compartments built in; or
 - (iv) the yacht, if it can be demonstrated that by virtue of the yacht's maneuverability it can effectively act as the rescue boat itself. In this case, the marked area shall be fully visible from the bridge wings or

other areas where the yacht may be operated. However, consideration shall be given to §17.2.3 above; and

- (v) if launching appliances are provided, these shall meet the requirements of §17.2.4.5(b) or §17.2.4.6 above.
- (c) The rescue boat does not need to be brought back onboard the yacht if the casualty and operating crew can be recovered from the rescue boat while it is still in the water.

17.2.5 Life Buoys

- .1 Life buoys shall be provided on the port and starboard sides of the bridge. They shall be equipped with self-activating light and smoke signals and shall be capable of quick release. Where this is impractical, they may be stowed at the side of the yacht and provided with conventional release arrangements.
- .2 Life buoys shall meet SOLAS requirements; however, they may be white in color.
- .3 A buoyant line is required to be attached to two of the life buoys and is to have a minimum length of 30 m. Reference should be made to the Table 13 above of life-saving appliances in §[17.1](#) above.
- .4 For yachts of less than 500 GT and of Category 2, the Light and Smoke Man Overboard (MOB) signal may be replaced by a SOLAS approved marker strobe light.
- .5 Each lifebuoy shall be marked with the yacht's name and Port of Registry.

17.2.6 Lifejackets

- .1 One adult SOLAS approved lifejacket shall be provided for each person on board plus spare adult lifejackets sufficient for at least 10% of the total number of persons on board, or two, whichever is the greater. Each lifejacket shall be fitted with a light and whistle.
- .2 There shall be at least two SOLAS approved inflatable lifejackets included in the number of lifejackets for use of the crew of any rescue boat or inflatable boat carried on board described in §17.2.6.1 above.
- .3 When children or infants are carried on the yacht, one child or infant SOLAS approved lifejacket shall be provided for each child or infant, as appropriate. In addition, spare life jackets shall be carried onboard for at least 10% of the total number of infants and/or children onboard.

- .4 Sufficient means of securing lifejackets to persons weighing up to 140 kg and a chest girth of up to 1,750 mm shall be provided as necessary.

17.2.7 Immersion Suits

- .1 One approved and appropriately-sized immersion suit complying with the requirements of §[17.1.1](#) above shall be provided for each person on board.
- .2 A yacht which operates between latitude of 30° North (N) and 30° South (S) need not be provided with immersion suits or exempted in accordance with Chapter I, §[2.3.2](#).
- .3 An appropriately-sized immersion suit must be provided for every person assigned to crew the rescue boat or assigned to the MES party according to SOLAS III. An immersion suit provided under this requirement may be used to comply with §17.2.7.1 above.
- .4 If applicable, immersion suits shall be provided for persons weighing up to 140 kg or with chest girths of 1,750 mm and for children.
- .5 The periodic testing of immersion suits shall be conducted according to *Life-Saving Appliances and Systems* ([MN 2-011-37](#)).
- .6 A yacht which operates outside of the parallels of latitude 30°N and 30°S or in areas where the seawater temperature at the time of operation is known and considered to be high enough to forego the safety provision of immersion suits, may apply to the Administrator for a dispensation or exemption from the requirements. Full details of the proposed location, period of operation, and established temperature data from recognized authorities shall be provided. Immersion suits shall always be provided for the rescue boat crew and for the crew on repositioning voyages.

17.2.8 Pyrotechnics

Flares, complying with the requirements of the LSA Code, shall be positioned in a readily accessible location and in the quantities stated in Table 13 in §[17.1](#) above.

17.2.9 Line Throwing Appliances

For yachts in Category 2, appliances capable of firing two shots of line are required; for all other categories, four shots of line capability is required.

17.2.10 Emergency Position-Indicating Radio Beacon (EPIRB)

- .1 A 406 megahertz (MHz) EPIRB shall be provided and installed in a readily accessible location ready to be manually released, capable of being placed in a

survival craft, or floating free if the yacht sinks. See *Frequency, Identification Numbers, Testing and Disposition of Satellite EPIRBs* ([MN 4-033-5](#)).

- .2 All EPIRBs are to be registered with the Administrator and are to be tested and serviced annually by an approved service provider.

17.2.11 Search and Rescue Transponder (SART)

The SART is to be stowed in an easily accessible position so that it can be rapidly placed in any survival craft. Means are to be provided in order that it can be mounted in the survival craft at a height of at least 1 m above sea level.

17.2.12 General Alarm

- .1 For a yacht of less than 500 GT this alarm may consist of the yacht's whistle or siren.
- .2 For a yacht of 500 GT and above the requirements of §17.2.12.1 above are to be supplemented by an electrically operated bell or klaxon system, which is to be powered from the yacht's main supply and also the emergency source of power (see §[14.4](#) above).
- .3 For yachts of 85 m in length and above, a public address system or other suitable means of communication shall be provided in addition to the requirements of §17.2.12.2 above.

17.2.13 Lighting

- .1 Alleyways, internal and external stairways, and exits giving access to the muster and embarkation stations shall be adequately lighted.
- .2 Adequate lighting is to be provided in the vicinity of survival craft, launching appliance(s) (when provided), and the area overboard in way of the launching position(s). The lighting shall be supplied from the emergency source of power.

17.2.14 Life-Saving Signals and Rescue Poster

When display space in the wheelhouse is restricted, the two sides of a SOLAS No. 2 poster (as contained in life raft equipment packs) may be displayed in lieu of a SOLAS No. 1 poster. Symbols used shall conform to *Fire Control Plans and Life-Saving Symbols* ([MN 2-011-10](#)).

18.0 NAVIGATIONAL LIGHTS, SHAPES, AND SOUND SIGNALS

18.1 General

- .1 Yachts shall comply with the requirements of COLREGS ‘72.
- .2 Navigation lights shall have a primary and secondary means of power. The secondary source of power shall comply with §[13.5.2.3](#) and §[14.4.1](#) above, as applicable.
- .3 For yachts less than 500 GT the requirement for duplication of navigation lights may be satisfied by having a spare lamp that can be fitted within three minutes while underway.
- .4 The navigation lights shall meet the performance standards in IMO Resolution [MSC.253\(83\)](#), *Adoption of the Performance Standards for Navigation Lights, Navigation Light Controllers and Associated Equipment*. This includes LED navigation lights.

19.0 NAVIGATIONAL AND BRIDGE EQUIPMENT AND BRIDGE VISIBILITY

19.1 Requirements

All yachts shall be provided with the following equipment in Table 14 below, as applicable:

Table 14
(see Sections of this Chapter as noted below)

Navigational Equipment	up to 149 GT	150 to 299 GT	300 to 499 GT	500 to 2,999 GT	3,000 GT and above
Standard Magnetic Compass (see § 19.2.1)	✓	✓	✓	✓	✓
Spare Magnetic Compass (see § 19.2.1.2)		✓	✓	✓	✓
Gyro Compass or Spare Magnetic Compass Bowl (see § 19.2.2)				✓	✓
Global Navigation Satellite System (GNSS) (see § 19.2.3)	✓	✓	✓	✓	✓
Automatic Identification System (AIS) (see § 19.2.4)			✓	✓	✓
Long-Range Identification and Tracking (LRIT) System (see § 19.2.5)			✓	✓	✓

Table 14
(see Sections of this Chapter as noted below)

Navigational Equipment	up to 149 GT	150 to 299 GT	300 to 499 GT	500 to 2,999 GT	3,000 GT and above
9 Gigahertz (GHz) Radar (see §19.2.6)			✓	✓	✓
3 GHz Radar (see §19.2.7)					✓
Radar Reflector (see §19.2.15)	✓				
Nautical Charts and Nautical Publications or Electronic Chart Display and Information System (ECDIS) (see §19.2.8)	✓	✓	✓	✓	✓
Pelorus or Compass Bearing device (see §19.2.1.1(c))	✓	✓	✓	✓	✓
Echo Sounder (see §19.2.10)			✓	✓	✓
Speed and Distance Measuring Device (see §19.2.9)			✓	✓	✓
Rudder, Propeller, Thrust, Pitch and Operational Mode Indicators (see §19.2.11)				✓	✓
Barometer (see §19.2.14)	✓	✓	✓	✓	✓
Anemometer and Inclinator (Sailing Yachts Only) (see §19.2.14)	✓	✓	✓	✓	✓
Signaling Lamp / Handheld Searchlight (see §19.2.12)	✓	✓	✓	✓	✓
Searchlight (see §19.2.12 and §19.2.13)	✓	✓	✓	✓	✓

Please refer to SOLAS V/19, *Carriage requirements for shipborne navigational systems and equipment*, for additional details.

19.2 Navigational Equipment Requirements

19.2.1 Standard Magnetic Compass

- .1 Every yacht shall be fitted with an efficient and approved magnetic compass complying with the following requirements, as appropriate:
 - (a) on a steel yacht, it shall be possible to correct the compass for coefficients B, C, and D;

- (b) the magnetic compass or a repeater shall be so positioned as to be clearly readable by the helmsman at the main steering position. It shall also be provided with an electric light; the electric power supply is to be a twin wire type;
 - (c) means shall be provided for taking bearings as near as practical over an arc of the horizon of 360°. This requirement may be met by the fitting of a Pelorus or, on a yacht other than a steel yacht, a handheld compass; and
 - (d) the compass shall be calibrated and a deviation log kept in accordance with *Magnetic Compasses Adjustment* ([MN 2-011-32](#)).
- .2 A spare magnetic compass interchangeable with the standard magnetic compass shall be provided on all yachts of 150 GT and above.
 - .3 For yachts under 300GT, the requirements of §19.2.1 above may be met by the use of a fluxgate compass, provided that a suitable back up power supply is available to power the compass in the event of a failure of the main electrical supply. Where such a compass incorporates a capability to measure magnetic deviation by undertaking a calibration routine, and where the deviation figures are recorded within the device, a deviation card is not required.
 - .4 If the yacht is intended to operate in polar regions (north of 70°N or south of 70°S), the effects on the magnetic compass shall be taken into consideration.

19.2.2 Gyro Compass

All yachts of 500 GT and above shall have a gyro compass complying with the following requirements, as appropriate:

- .1 a gyro compass with the ability to determine and display their heading by shipborne non-magnetic means;
- .2 the helmsman shall be able to clearly read the display at the main steering position. The gyro compass shall also transmit heading information for input to the applicable equipment;
- .3 a gyro compass heading repeater with the ability to supply heading information visually at the emergency steering position, if provided; and
- .4 a gyro compass bearing repeater shall be provided to take bearings, over an arc of the horizon of 360°, using the gyro compass. However, yachts of less than 1,600 GT shall be fitted with such means as far as is reasonable and practicable.

19.2.3 Global Navigation Satellite System (GNSS)

Every yacht shall carry a GNSS which is accurately integrated with other equipment.

19.2.4 Automatic Identification System (AIS)

.1 AIS Class-A

All yachts of 300 GT and above shall be fitted with an approved AIS in accordance with SOLAS V/19. Refer to *Automatic Identification Systems (AIS)* ([MN 2-011-17](#)).

.2 AIS Class-B

- (a) Any yacht of less than 300 GT may be fitted with a Class-B AIS.
- (b) Daughter Craft, such as a tender or other watercraft, associated with a yacht may be fitted with a dedicated Class-B AIS. Where fitted, a permanent Maritime Mobile Service Identity (MMSI) number must be assigned to each Daughter Craft by the Administrator.
 - (i) The Daughter Craft MMSI number will be listed on the yacht's radio station license as a permanent identification of the Daughter Craft. It shall be programmed in the Daughter Craft AIS.
 - (ii) If other radio equipment (e.g., VHF Digital Selective Calling (DSC)) is fitted onboard the Daughter Craft, the MMSI number shall be programmed in this equipment.
 - (iii) The Administrator shall be notified if the yacht ceases to tow or carry the Daughter Craft.

19.2.5 Long-Range Identification and Tracking (LRIT) System

Yachts of 300 GT and above shall comply with the requirements of LRIT in accordance with SOLAS V. Please refer to *Long-Range Identification and Tracking (LRIT) of Ships* ([MN 2-011-25](#)).

19.2.6 9 GHz Radar (X-band)

All yachts of 300 GT and above shall carry an approved 9 GHz radar.

19.2.7 3 GHz Radar (S-band)

All yachts of 3,000 GT and above shall carry a 3 GHz radar or where appropriate by the Administrator a second 9 GHz radar.

19.2.8 Nautical Charts and Nautical Publications or ECDIS

Every yacht shall carry nautical charts and nautical publications to plan and display the yacht's route for the intended voyage and to plot and monitor positions throughout the voyage. An approved ECDIS may also be accepted as meeting the chart carriage requirements provided that the provisions of *Nautical Chart and Publication Carriage and Electronic Chart Display and Information System (ECDIS) Requirements* ([MN 7-041-6](#)) are in place.

19.2.9 Speed and Distance Measuring Device

All yachts of 300 GT and above shall carry a speed and distance measuring device, or other means, to indicate speed and distance through the water.

19.2.10 Echo Sounder

All yachts of 300 GT and above shall carry an echo sounding device to measure and display the available depth of water.

19.2.11 Rudder, Propeller, Thrust, Pitch, and Operational Mode Indicators

All yachts of 500 GT and above shall carry rudder, propeller, thrust, pitch, and operational mode indicators. These indicators shall be located so that they may be clearly read at the conning position.

19.2.12 Signaling Lamp

Every yacht shall carry an approved signaling lamp and/or handheld searchlight that is not solely dependent on the yacht's main source of electrical power.

19.2.13 Searchlight

Every yacht shall carry an efficient fixed or portable searchlight suitable for MOB search and rescue operations. This may be the approved signaling lamp required by §19.2.12 above.

19.2.14 Instruments

Every yacht shall carry a barometer. Every sailing yacht shall carry an anemometer and an inclinometer.

19.2.15 Radar Reflector

On yachts less than 150 GT, if practicable, a radar reflector, or other means, to enable detection by ships navigating by radar at both 9 and 3 GHz shall be carried.

19.3 Bridge Navigational Watch Alarm System (BNWAS)

Certain sized yachts are required to be fitted with an approved BNWAS. Refer to *Bridge Navigation Watch Alarm Systems* ([MN 2-011-40](#)) for full details.

19.4 Bridge Visibility

- .1 Yachts of 55 m or more in length shall comply with SOLAS V/22. Alternative arrangements may be considered by the Administrator.
- .2 Yachts of less than 55 m in length should comply with SOLAS V/22 as far as is reasonable and practicable to do so.
- .3 Windows to the conning position(s) shall not be of either polarized or tinted glass (also see [§5.5](#) above). Portable tinted screens may be provided for selected windows.
- .4 Windows which are not inclined from the vertical plane top out in accordance with SOLAS V/22 shall have appropriate measures to avoid adverse reflections from within to the satisfaction of the RO.
- .5 Where the yacht's side is not fully visible from the bridge wing, wing station, or maneuvering station, alternative means for ensuring visibility (e.g., cameras), may be considered on a case-by-case basis, giving consideration to image quality, night vision, display screen size, and location.

20.0 RADIO

20.1 General

All yachts, regardless of GT, shall carry radio transmitting and receiving equipment appropriate for the Sea Areas in which the yacht operates. Sea Areas are as defined in SOLAS IV.

- .1 All yachts shall be equipped, at a minimum, as provided in Table 15 below.
- .2 Yachts of 300 GT and above must ensure the operability of radio installations at all times. This can be done by duplication of equipment, shore-based maintenance, or at-sea electronic maintenance capability.
- .3 For yachts less than 300 GT, alternative arrangements for the radio installations shall be considered by the Administrator on a case-by-case basis.

- .4 Yachts certified for navigation in Sea Area A4 must have at least two of the methods referenced in §20.1.2 above.
- .5 All yachts shall be able to transmit a maritime distress alert by at least two separate and independent means. One of the individual means of transmitting a maritime distress alert may be satisfied by a satellite EPIRB, if this is used as the secondary means of distress alerting. See §17.0, Table 13 of this Chapter for requirements on the carriage of two-way radiotelephone sets, EPIRBs, and SARTs.

Table 15

A1 ⁵	A1 + A2 ⁴	A1 + A2 + A3		A1 + A2 + A3 + A4
		Either	Or	
Navtex ¹	Navtex ¹	Navtex ¹	Navtex ¹	Navtex ¹
VHF DSC/RT	VHF DSC/RT* VHF RT*	2 VHF DSC/RT*	2 VHF DSC/RT*	2 VHF DSC/RT*
---	MF(DSC) Radio Telephone Or App. GMDSS Satellite ship earth station ³	MF(DSC) Radio Telephone Or App. GMDSS ship earth station ³	MF/HF(DSC) ² Radio Telephone	MF/HF(DSC) ² Radio Telephone
---	---	---	---	App. GMDSS ship earth station

Table Notes:

1. If the yacht is navigating in an area where an international NAVTEX service is not provided, then the NAVTEX receiver shall be supplemented by an additional means of receiving Maritime Safety Information (MSI) transmissions such as the GMDSS Safety Net EGC.
2. Incorporating Narrow Band Direct Printing (NBDP) telegraphy or an alternative means of receiving MSI transmissions in the Sea Areas in which the yacht is operating.
3. For yachts navigating in Sea Area A2, in lieu of a MF(DSC) radio installation, an approved GMDSS Satellite service provider may be installed. For navigation in areas where no Sea Area A2 is declared, the yacht is required to be equipped with an approved GMDSS ship earth station.
4. Yachts of category 0 or 1 which frequently navigate outside of Sea Area A2, the Administrator recommends full compliance with SOLAS IV.

5. If equipment is provided only for Sea Area A1, then this shall be noted as an additional operational limitation on the compliance certificate.

* *As the yacht is equipped with two VHF DSC/RT units, duplication of equipment (the VHF DSC/RT installations), as required by section §20.1.3 and §20.1.4, is not required.*

20.2 Sources of Energy

- .1 All yachts regardless of GT shall comply with SOLAS IV, as amended by this section.
- .2 Yachts of less than 300 GT not meeting the requirements of §[13.5.2](#) above shall have sufficient reserve power supply to operate the radio equipment for a minimum of three hours.

20.3 Watches

While at sea, a yacht regardless of GT shall maintain a continuous watch in accordance with SOLAS IV.

20.4 Radio Personnel

A yacht shall carry at least one person qualified for distress and safety radio communication purposes. This person shall hold a Certificate of Competence (CoC) issued or endorsed by the Administrator. Refer to the *RMI Requirements for Seafarer Certification* ([MI-118](#)).

20.5 Global Maritime Distress and Safety System (GMDSS) Logbooks

All yachts are required to keep records of communications relating to distress, urgency, safety traffic, records of important incidents connected with the radio service, regular positions of the yacht, and results of tests carried out on the radio equipment. Records must be stored on board and be available for inspection as required.

21.0 PUBLICATIONS

Yachts shall carry the most up-to-date and applicable versions¹⁰ of the below Table 16 list of publications, based on the GT of the yacht as indicated. Please note these requirements represent the minimum in terms of compliance. Refer to *Requirements on Carriage of Publications On Board Ships* ([MN 1-000-3](#)).

¹⁰ Please note, in determining what version is applicable, a number of factors need to be taken into account, including but not limited to the date that the keel of the yacht was laid.

Table 16

Publication	up to 299 GT	300 to 399 GT	400 to 499 GT	500 GT and above
COLREGS	✓	✓	✓	✓
IAMSAR Vol. III	✓	✓	✓	✓
Code of Signals	✓	✓	✓	✓
ILLC	✓	✓	✓	✓
ICS	✓	✓	✓	✓
ISM	-	R*	R*	✓
ISPS	-	R*	R*	✓
MARPOL**	-	-	✓	✓
MI-103	✓	✓	✓	✓
MI-300	✓	✓	✓	✓
NAUTCH-P	✓	✓	✓	✓
NAUTCH-E	✓	✓	✓	✓
NAUTICAL ALMANAC	✓	✓	✓	✓
SAILING DIRECTIONS-P	✓	✓	✓	✓
SAILING DIRECTIONS-E	✓	✓	✓	✓
TIDE TABLES-P	✓	✓	✓	✓
TIDE TABLES-E	✓	✓	✓	✓
LIGHT LIST-P	✓	✓	✓	✓
LIGHT LIST-E	✓	✓	✓	✓
NTVRP	-	-	✓	✓
SOLAS	-	✓	✓	✓
STCW	✓	✓	✓	✓
STMAN	✓	✓	✓	✓

* *R = Recommended*

** *Yachts of 400 GT and above and all yachts that are certified to carry more than 15 persons shall carry a copy of MARPOL.*

22.0 DECK EQUIPMENT

22.1 Equipment

Yachts will be considered to have adequate deck equipment if such equipment is approved and installed in accordance with the Rules of Class and complies with the requirements of this Code.

22.2 Anchors

A minimum of two anchors are required on all yachts, one of which shall be rigged and ready for use at all times. The deployment system shall be able to be fully operational when there is a power failure.

22.3 Sailing Yachts

- .1 The sizing of anchors and cables for sailing yachts shall take into account the additional windage effect of the masts and rigging.
- .2 For square rigged sailing yachts, the guidance on the approximate increase in anchor mass and cable strength required is as follows:
 - (a) for sailing yachts of less than 50 m in length, typically 50% above the requirements for a typical motor yacht having the same total longitudinal profile area of hull and superstructure as the sailing yacht under consideration; and
 - (b) for sailing yachts 100 m in length and over, typically 30% above the requirements for a typical motor yacht having the same total longitudinal profile area of hull and superstructure as the sailing yacht under consideration; and
 - (c) for square rigged sailing yachts of 50 m and more but less than 100 m in length, the increase should be obtained by linear interpolation.

22.4 Towing Arrangements

- .1 Accessible efficient strong securing points shall be provided for the attachment of towlines for the yacht to tow and be towed, fore and aft, respectively.
- .2 All yachts of 500 GT and above shall be provided with a documented emergency towing procedure, as outlined in SOLAS II-1. Such procedures shall be carried on board the yacht for use in emergency situations and be based on existing arrangements and equipment available on board. Further guidance for the development of this document can be found in IMO Circular [MSC.1/Circ.1255](#), *Guidelines for Owners/Operators on Preparing Emergency Towing Procedures*.

23.0 MEDICAL STORES

23.1 General

- .1 All yachts shall carry medical stores as outlined by *Medical Care On Board Ship and Ashore: Medicine Chest, Recordkeeping and Responsibilities and Training for Medical Care* ([MN 7-042-1](#)), as applicable, which provides details of medicines and medical stores to be carried or their suitable equivalent.
- .2 Medical training requirements for the crew of the yacht are provided in the *RMI Requirements for Seafarer Certification* ([MI-118](#)).

24.0 YACHT-SHORE TRANSFER

24.1 Tenders

- .1 A tender shall be fit for its intended use.
- .2 A lifeboat or rescue boat may be utilized as a tender, provided that the craft, equipment, and its launching appliances are certified and in compliance with the LSA Code.
- .3 Safety equipment shall be provided on each tender as appropriate to its intended range and areas of operation. Such safety equipment shall include, but not be limited to, appropriately sized life jackets for each person on board the tender, appropriate radio communications, a portable fire extinguisher, and a mechanical or portable foghorn or klaxon.
- .4 The tender itself shall be clearly marked with the number of persons that it can safely carry and the name of the mother yacht.
- .5 In the case of crafts with gasoline powered engines, the safety requirements for the carriage of gasoline outlined in [§10.1](#) above shall be met.
- .6 An official TSC confirming an equivalence of safety shall be issued by an AR. This statement has a validity of five years, subject to required annual surveys being satisfactorily held.
- .7 It is the responsibility of the Master to ensure that the operations of any water craft belonging to the mother yacht of any type are in compliance with the rules and regulations imposed by the local port authorities for the area of operation, including any training as required.

24.2 Pilot Transfer Arrangements

- .1 Yachts engaged on voyages in the course of which pilots may be employed shall be provided with pilot transfer arrangements. These arrangements shall have due regard for the international standards of safe practice for the boarding and landing of pilots in accordance with SOLAS V.
- .2 Periodic inspections and tests to confirm proper construction, installation, operation, and maintenance of equipment for the boarding arrangements of pilots shall be carried out in accordance with *Pilot Transfer Arrangements* ([MN 7-041-3](#)).

24.3 Gangways, Accommodation Ladders, and Passerelles

- .1 Safe passage for all persons to and from the yacht shall be provided when the yacht is in port or at anchor.

- .2 The construction, installation, maintenance, and inspection/survey requirements for gangways and accommodation ladders on yachts shall be guided by the requirements of *Means of Ship Embarkation/Disembarkation* ([MN 7-043-1](#)).
- .3 For the purpose of §24.3.2 above, passerelles installed on any yacht shall be regarded as a means of embarkation/disembarkation.
- .4 If provided, a gangway or equivalent does not need to be of an Approved Type if the yacht is less than 30 m in Length.
- .5 Approved accommodation ladders shall be provided on a yacht of 120 m or more in Length.
- .6 Access equipment and immediate approaches to it shall be adequately illuminated.
- .7 Reference standards include:
 - (a) BSMA78:1978, Specification for aluminum shore gangways (excluding the maximum overall widths specified in table 2);
 - (b) BSMA89:1980, Specification for accommodation ladders;
 - (c) ISO7061:1993, Shipbuilding - Aluminum shore gangways for seagoing vessels;
 - (d) ISO5488:1979, Shipbuilding - Accommodation ladders;
 - (e) ISO799: 2004, Ships and marine technology - Pilot ladders; and
 - (f) ISO7364:1983, Shipbuilding and marine structures - Deck machinery - Accommodation ladder winches.

25.0 HELICOPTER AND LANDING FACILITIES

All yachts, where helicopter operations to and from the yacht are performed, shall comply with the applicable rules and regulations in accordance with [Annex 2](#) of this Code.

26.0 SUBMERSIBLES

26.1 General Requirements

- .1 All submersibles to be installed on a yacht shall be designed and built in accordance with the Rules of Class and maintained in Class.

- .2 When installing a submersible, special consideration shall be given to the stability and structure of the yacht.

26.2 Lifting Appliances and Attachments

- .1 The design and construction of the lifting appliance(s) and their attachment to the structure of the yacht and the associated stowage of the submersible shall be in accordance with the Rules of Class or certified as suitable for their intended use.
- .2 Lifting appliances and associated equipment installed on equipment where “man-riding” is required, shall be maintained and tested in accordance with §[27.2](#) of this Chapter.
- .3 Where no “man-riding” is required, the equipment shall be maintained and tested to the recommendations as specified in *Voluntary Compliance with ILO Convention No. 152 (TC 3)*.

26.3 Operation

- .1 The safe operation of the submersible is the responsibility of the Master.
- .2 The Master shall ensure that the operator of the submersible has had the proper training and is certified to operate the submersible.
- .3 An operations manual shall be available on board the yacht. The manual shall contain, as a minimum, the lowering and recovery procedures, fire-fighting, and safety procedures and drills.

27.0 SAFE WORKING PRACTICES

27.1 Safe Work Aloft, Over the Side, at Heights, and on the Bowsprit of Sailing Yachts

- .1 When work aloft, over the side, at heights, or access to the rigging or bowsprit is likely to be an operational necessity, provisions shall be made to enable this work to be performed safely. The arrangements and procedures shall be documented in the SMS to the satisfaction of the Administrator.
- .2 The arrangements and procedures shall be based on a formal risk assessment and on established safe working practices for the type of yacht. The procedures must address issuing a permit to work for each occasion. The arrangements may include, but not be limited to:
 - (a) safety nets below the bowsprit;
 - (b) safety grab-rails (pulpit) fixed along the bowsprit to act as handholds and safety points for safety harnesses;

- (c) appropriate safety harnesses with a fall arrest device and personnel protective equipment (PPE) shall be provided;
 - (d) sufficient footropes permanently rigged to enable the crew to stand on them while working out on the yards or on the bowsprit;
 - (e) safety jackstays (in metal) fixed along the top of the yards, to provide handholds and act as strong points for safety harnesses;
 - (f) fixed static lines for attaching lanyards; and
 - (g) means of safely going aloft, such as:
 - (i) fixed metal steps or ladders with anti-slip surfaces attached to the mast;
 - (ii) traditional ratlines; or
 - (iii) bosun's chair.
- .3 The use of "rail and trolley" systems or similar systems for undertaking work over the side is permitted, provided that:
- (a) the systems installed comply with and are certified to BS 795 and BS 7883 for manufacturing, installation, and pre- and post-installation testing for Class D Fall Protection Equipment;
 - (b) the systems are installed, maintained, and tested according to the manufacturer's instructions. Testing shall be witnessed by the RO;
 - (c) the operations of these systems are fully described in the SMS manual for safe working practice; and
 - (d) a full risk assessment is performed prior to the work being undertaken and that the crew members or contractors working with the equipment are trained and competent for the use of these systems on board the yacht.
- .4 Where "rail and trolley" systems are installed, the method of installation to the particular surface and underlying construction (substrate) needs to be tested in accordance with the requirements as per §27.1.3 (a) and (b) above to be considered approved and suitable for supporting crew members working over the side.

- .5 If a particular method of attachment of the systems to the substrate has been previously approved and documentary evidence can be provided, only post-installation testing shall be required, as below:
- (a) For yachts with existing “rail and trolley” systems:
 - (i) if it cannot be confirmed that the design of the attachment to the substrate is identical to that used in the type approval process completed by the system’s manufacturer, or through approval of the design on another vessel, separate pre-installation testing is required to be satisfactorily completed prior to the system being installed; or
 - (ii) if fitted with systems for which there is evidence that the system complies with the BS standards but without evidence that the installation test was witnessed by an RO, the system shall not be used until the installation arrangements have been approved by the RO; or
 - (iii) if fitted with systems for which there is evidence that the system is in compliance with the BS standards and that the installation was approved but there is no evidence of post-installation testing, the systems shall be subject to post installation testing.
 - (b) For yachts with new “rail and trolley” systems, in addition to the systems requiring type approval, the installation of the system to the substrate of the yacht shall be tested to meet the requirements of the latest edition of the BS Standards in force at the time of the installation of the system.

27.2 Man-Riding Cranes

Man-riding cranes shall meet the following conditions:

.1 Design

Except those covered by §[17.1.2](#) above, deck cranes or other lifting appliances intended to be used for the purpose of “man-riding,” shall be certified as such through compliance with a recognized national or international standard deemed acceptable by the Administrator. Certification of such appliances shall be carried out to the satisfaction of the RO.

.2 Testing and Maintenance

Annual and five-year testing and maintenance shall be in accordance with the original manufacturer’s instructions.

.3 Operations

Operations of the man-riding cranes and other lifting appliances shall:

- (a) be in accordance with the original equipment manufacturer's operating instructions; and
- (b) adhere to any restrictions established by the original equipment manufacturer or RO approving the equipment.

The operating instructions shall be part of the SMS or mini-ISM, as applicable, and posted locally to any controls along with any restrictions as per §27.2.3(b) above.

27.3 Noise and Vibration

- .1 Yachts of 1,600 GT and above with a keel lay date on or after 01 January 2015 shall comply with the IMO Code on Noise Levels On Board Ships (Noise Code).

Yachts less than 1,600 GT with a keel lay date on or after 01 January 2015 shall meet the requirements of the Noise Code, so far as is reasonable and practicable.

- .2 Noise and vibration in the accommodation spaces shall be limited to the maximum extent possible and in accordance with the Noise Code and with any other relevant international standards as far as is reasonable and practicable.
- .3 Accommodation, recreational, and catering facilities shall be located as far as is reasonable and practicable from the engines, steering gear rooms, deck winches, ventilation, heating and air-conditioning equipment, and other noisy machinery.
- .4 Acoustic insulation or other appropriate sound-absorbing materials shall be used in the construction and finishing of bulkheads, deck heads, and decks within the sound-producing spaces as well as self-closing noise-isolating doors for machinery spaces.

27.4 Training Manual

- .1 The training manual shall include details of established safe working practices specific to the yacht, as well as guidance on:
- (a) training for members of the crew;
 - (b) personal clothing and protection from injury;
 - (c) health and safety awareness;

- (d) prevention of pollution; and
 - (e) life-saving appliances and fire-fighting equipment.
- .2 The training manual shall be yacht type specific and contain instructions for the actual equipment brands/types on board. The information in regards to the life-saving appliances and fire-fighting equipment provided on the yacht and the best methods of survival shall be explained in easily understood terms and illustrations, where appropriate (reference should be made to SOLAS III/35 and SOLAS II-2/15).
 - .3 The training manual shall be written in the working language of the yacht and in English.
 - .4 The Master shall conduct drills and/or trainings for the crew. Refer to RMI Maritime Regulations ([MI-108](#)), regulation 7.41, as applicable. The drills and/or trainings shall also be documented in accordance with the SMS manual.

27.5 Instructions for Onboard Maintenance

Instructions shall be provided describing the maintenance procedures for all safety and fire-fighting appliances in easily understood terms and illustrated wherever possible. Refer to *Life-Saving Appliances and Systems* ([MN 2-011-37](#)) and *Maintenance and Inspection of Fire Protection Systems and Appliances* ([MN 2-011-14](#)).

27.6 Safety Management System (SMS)

All yachts shall comply with §[1.11](#) of this Chapter in regard to the SMS or mini-ISM as applicable.

27.7 Maritime Security

All yachts of 500 GT and above shall comply with §[1.12](#) of this Chapter in regard to ISPS Code requirements and SOLAS XI-2.

28.0 PASSENGERS

28.1 Limitations

- .1 Yachts shall carry no more than 12 passengers regardless of the number of beds or berths provided. Yachts that wish to carry more than 12 passengers will be considered PAXYs and, as such, must meet the requirements of Chapter III of this Code.

- .2 Yachts may apply to the Administrator for a temporary authorization to carry more passengers, on an excursion of very limited duration and range, during which no additional passenger would be berthed on board for an overnight passage. In order to apply for such a dispensation, the owner or Master may request an *Application for Temporary Dispensation to Carry Additional Persons On Board* ([YTEC-01](#)), from the Administrator.

29.0 MANNING

29.1 Minimum Safe Manning

Refer to *Minimum Safe Manning Requirements for Vessels* ([MN 7-038-2](#)) for yacht minimum safe manning requirements.

29.2 Crew Certification

For information on crew certification, refer to *RMI Requirements for Seafarer Certification* ([MI-118](#)), §7.0.

CHAPTER III:
PASSENGER YACHTS (PAXYs)

1.0 STATUTORY AND NATIONAL REQUIREMENTS

- .1 All PAXYs¹¹ shall comply with the requirements outlined in this Chapter III, as well as the applicable requirements of Chapter I of this Code and all other applicable RMI laws and regulations.
- .2 Refer to *RMI Yacht Compliance Requirements* ([MI-103A](#)) for a comprehensive matrix of statutory and national requirements.
- .3 The Administrator may consider, on a case-by-case basis, the registration of PAXYs, provided that the operations, design criteria, construction standards, and other safety measures comply to the applicable chapters of SOLAS, or any other substantial equivalency submitted to the IMO for passenger ships carrying not more than 36 passengers that is acceptable to the Administrator.
- .4 PAXYs shall be built to the standards of applicable international conventions for passenger ships carrying not more than 36 passengers and shall be constructed under the supervision of, and certified as, a passenger ship by a Classification Society. Where it is not reasonable or practicable for the foregoing standards to be met, a yacht constructed and certified under the *Red Ensign Group (REG) Yacht Code*, Part B and Common Annexes may, at the discretion of the Administrator, be accepted as an equivalent to the standards of applicable international conventions.
- .5 In instances where the applicable regulations of SOLAS or any other substantial equivalency submitted to the IMO cannot be met, the Administrator may, on a case-by-case basis, consider equivalent arrangements as referenced in [Chapter I, §2.3](#) of this Code.

1.1 **Convention on the International Regulations for Preventing Collisions at Sea, 1972 (COLREGS '72)**

All PAXYs shall comply with the requirements of COLREGS '72.

1.2 **International Convention on Tonnage Measurement of Ships, 1969 (ITC)**

All PAXYs of 24 m or more in length are required to be surveyed and admeasured to the ITC and issued with an International Tonnage Certificate.

1.3 **International Convention for the Prevention of Pollution from Ships (MARPOL)**

All PAXYs are required to comply with the provisions of MARPOL, subject to the applicability of each MARPOL Annex.

¹¹ The general term “yacht” when used throughout this Chapter, shall mean a PAXY.

MARPOL electronic record books and logbooks are permitted to be used. They shall be approved by the Administrator where required by international convention. See *Electronic Record Books and Logbook Systems* ([MN 7-041-5](#)).

Refer to *Requirements for MARPOL Surveys for All Yachts* ([MN 2-013-11](#)).

1.3.1 MARPOL Annex I

All PAXYs shall comply with the requirements of MARPOL Annex I. PAXYs of 400 GT and above shall be surveyed to verify compliance and issued with the following:

- (a) International Oil Pollution Prevention Certificate; and
- (b) Supplement to the International Oil Pollution Prevention Certificate; and shall maintain
- (c) an Oil Record Book (ORB).*

**All yachts less than 400 GT shall maintain a similar ORB.*

1.3.2 MARPOL Annex IV

- .1 PAXYs of 400 GT and above or certified to carry more than 15 persons, regardless of tonnage, shall comply with the requirements of MARPOL Annex IV. Yachts, to which Annex IV applies, shall be surveyed to verify compliance and issued with an International Sewage Pollution Prevention Certificate.
- .2 In certain cases, MARPOL Annex IV stipulates criteria for “ships ...which are certified to carry more than 15 persons.” The Administrator recognizes that this is not always applicable to all yachts due to non-mandatory requirements of certain certificates.

Therefore, for the purposes of MARPOL Annex IV, where the number of persons carried on board is a stipulated criterion, the figure to be used shall be that number shown on the Passenger Ship Safety Certificate (supplement).

1.3.3 MARPOL Annex V

- .1 All PAXYs shall comply with the requirements of MARPOL Annex V. PAXYs of 400 GT and above and those certified to carry 15 persons or more, regardless of tonnage, shall be surveyed to verify compliance and must maintain a Garbage Record Book.
- .2 All PAXYs of 100 GT and above or certified to carry 15 persons or more, regardless of tonnage, are required to have a Garbage Management Plan.

- .3 In certain cases, MARPOL Annex V stipulates criteria for “every ship ...which is certified to carry 15 or more persons.” The Administrator recognizes that this is not always applicable to all PAXYs due to non-mandatory requirements of certain certificates.

Therefore, for the purposes of MARPOL Annex V, where the number of persons carried on board is a stipulated criterion, the figure to be used shall be that number shown on the Passenger Ship Safety Certificate (supplement).

1.3.4 MARPOL Annex VI

All PAXYs shall comply with the requirements of MARPOL Annex VI. PAXYs of 400 GT and above are required to be surveyed to verify compliance and be issued with the following:

- (a) International Air Pollution Prevention Certificate (IAPPC); and
- (b) Supplement to the IAPPC; and maintain an
- (c) Ozone-Depleting Substances Record Book; and
- (d) International Energy Efficiency Certificate (IEEC); and
- (e) Ship Energy Efficiency Management Plan (SEEMP).
- (f) In addition, PAXYs that are required to comply with Regulation 13 of Annex VI shall have an Engine Technical File and an Engine IAPPC (EIAPPC) for each marine diesel engine over 130 kW.

1.4 Anti-Fouling

- .1 All PAXYs shall comply with the requirements of the International Convention on the Control of Harmful Anti-fouling Systems on Ships (AFS Convention). All yachts of 400 GT and over and engaged in international voyages shall be issued with the following:
- (a) International Anti-fouling System Certificate; and
 - (b) Record of Anti-fouling Systems.
- .2 Yachts of 24 m or more in length but less than 400 GT engaged in international voyages shall carry a Declaration on Anti-fouling Systems signed by the owner or their representative. The Declaration shall be accompanied by appropriate documentation.

1.5 International Convention for the Control and Management of Ships' Ballast Water and Sediments, 2004 (BWM Convention)

All PAXYs constructed to carry ballast water shall comply with the requirements of the BWM Convention.

1.6 Nairobi International Convention on the Removal of Wrecks, 2007 (WRLC)

All PAXYs of 300 GT and above are required to be insured and certificated under the WRLC. Refer to *Nairobi International Convention on the Removal of Wrecks, 2007 Certification Requirements* ([MN 2-011-45](#)).

1.7 International Convention on Civil Liability for Bunker Oil Pollution Damage (CLBC)

All PAXYs of 1,000 GT and above are required to be insured and certificated under the CLBC. Refer to *Civil Liability for Bunker Oil Pollution Damage, 2001, Certification Requirements* ([MN 2-011-27](#)).

1.8 Athens Convention Relating to the Carriage of Passengers and Their Luggage by Sea (PAL)

All PAXYs are required to be insured and certified under the PAL Convention.

Refer to *Athens Convention Relating to the Carriage of Passengers and Their Luggage by Sea, 2002, Certification Requirements* ([MN 2-011-46](#)) for further details.

1.9 International Convention on Load Lines, 1966 (ILLC)

All PAXYs shall be surveyed in accordance with the applicable provisions of the ILLC as modified by this Code and be issued with the following:

(a) International Load Line Certificate; and

(b) Record of Conditions of Assignment.

1.10 International Convention for the Safety of Life at Sea (SOLAS)

All PAXYs shall comply with the SOLAS requirements as outlined below.

1.10.1 SOLAS Chapter II-1, II-2, III, and IV: Passenger Ship Safety Certificate

All PAXYs are required to be inspected and surveyed under the requirements of SOLAS Chapters II-1, II-2, III, and IV and any other relevant requirements of SOLAS for passenger ships and shall be issued a Passenger Ship Safety Certificate to which a

Record of Equipment for the Passenger Ship Safety Certificate (Form P) shall be permanently attached.

1.10.2 Classification and Certification

- .1 All PAXYs shall maintain classification and statutory certification with a Classification Society. Refer to *Organizations Acting on Behalf of the Republic of the Marshall Islands Maritime Administrator* ([MG 2-11-15](#)), for a list of the Administrator recognized Classification Societies.
- .2 PAXYs shall have a class passenger ship or passenger yacht notation and must maintain statutory compliance with the PAXY requirements regardless of whether the yacht is operating in a private capacity under a private yacht COR.

1.10.3 SOLAS XI-1/3: IMO Number

- .1 All PAXYs of 100 GT and above shall be marked with their IMO number.
- .2 The permanent marking shall be plainly visible and shall be painted in a contrasting color on a horizontal surface visible from the air.
- .3 The permanent marking referred to in §1.10.3.2 above shall be not less than 200 mm in height. The width of the marks shall be proportionate to the height.
- .4 In addition, the permanent marking shall be located in an unobstructed location on an end transverse bulkhead of the machinery space.
- .5 The permanent marking referred to in §1.10.3.4 above shall not be less than 100 mm in height. The width of the marks shall be proportionate to the height. This marking may be made by raised lettering, by cutting it in, by center punching it, or by any other equivalent method of marking the identification number which ensures that the marking is not easily expunged.
- .6 For PAXYs constructed of a material other than steel or metal where the requirements of marking as referred in §1.10.3.5 above are not feasible, alternative methods of permanent marking may be approved by the Administrator.

1.11 International Safety Management (ISM) Code

All PAXYs are required to comply with the requirements of SOLAS Chapter IX and the ISM Code and be issued with the following:

- (a) A copy of the Document of Compliance (DoC); and
- (b) Safety Management Certificate (SMC).

See *International Safety Management (ISM) Code* ([MN 2-011-13](#)) for further details.

1.12 International Ship and Port Facility Security (ISPS) Code

All PAXYs are required to comply with the requirements of SOLAS Chapter XI-2 and the ISPS Code and be issued an International Ship Security Certificate (ISSC).

See *International Ship and Port Facility Security (ISPS) Code* ([MN 2-011-16](#)) for further details.

1.13 Maritime Labour Convention, 2006 (MLC, 2006)

- .1 All PAXYs are required to comply with the requirements of MLC, 2006 and shall be subject to inspections to verify compliance.
- .2 All PAXYs of 500 GT or more shall carry on board a Maritime Labour (ML) Certificate evidencing compliance.
- .3 For PAXYs less than 500 GT, certification is not required, but voluntary certification is recommended.

1.14 International Code of Safety for Ships using Gases or other Low-flashpoint Fuels (IGF) Code

Where low-flashpoint fuel is used for propulsion machinery, auxiliary power generation machinery, and/or other purpose machinery, the requirements of the IGF Code shall be applicable for all PAXYs:

- (a) for which the building contract is placed on or after 1 January 2017; or
- (b) in the absence of a building contract, the keel of which was laid or which was at a similar stage of construction on or after 1 July 2017; or
- (c) the delivery of which is on or after 1 January 2021.

1.15 Inventory of Hazardous Materials (IHM)

- .1 All PAXYs of 500 gross tons and above, irrespective calling at a European Union (EU) Member State port or anchorage must carry on board a Statement of Compliance (SoC), supplemented by an IHM.
- .2 See *Inventory of Hazardous Materials* ([MG 2-11-9](#)) for further details.

1.16 Standards of Training, Certification and Watchkeeping for Seafarers, 1978 (STCW)

All PAXYs shall have a Minimum Safe Management Certificate (MSMC), and the crew must be appropriately certified in accordance with [§9.0](#) of this Chapter.

2.0 CONVENTION SURVEYS

2.1 Survey Standards

- .1 Statutory and other certification work may be undertaken by those organizations as specified in *Organizations Acting on Behalf of the Republic of the Marshall Islands Maritime Administrator* ([MG 2-11-15](#)).
- .2 Further, entities authorized by the RO to conduct in water surveys, radio surveys, etc., are also duly recognized by the Administrator.

2.2 Survey Requests

All requests for survey and certification must be made to an appropriate RO.

2.3 Statements of International Convention Voluntary Compliance

PAXYs that voluntarily comply with the provisions of an international convention or code, which would not otherwise apply to the particular yacht, shall have Statements of International Convention Voluntary Compliance issued instead of convention certificates of compliance.

3.0 MAINTAINING COMPLIANCE WITH THE CODE

3.1 General

In accordance with RMI laws and regulations, all yachts with a PAXY registration shall be inspected annually by an AR, as applicable, to verify compliance with this Code. This Compliance Verification is in addition to, and separate from, any other inspections or surveys that may be required to meet Class or international statutory-requirements.

See *Conducting Surveys and Issuing International Convention and National Certificates for Commercial Yachts, Passenger Yachts, and Yachts Engaged in Trade* ([MN 2-011-53](#)) for further guidance on compliance verification requirements.

3.2 Statutory Compliance and RMI Certification

Every PAXY shall maintain valid statutory international convention certification issued by a RO and must also maintain a valid RMI PAXY Compliance Certificate (PAXYCC).

- .1 All PAXYs, regardless of size, shall be certified for compliance to the international statutory conventions by an RO.

- .2 It shall be the responsibility of owners/managers and Masters to ensure that their yachts are in compliance with the requirements of all applicable international treaties, conventions, protocols, codes, and agreements which have come into force and to which the RMI is a party.
- .3 It is the responsibility of the owner/manager and Master to maintain the validity and endorsement of all applicable certificates at all times. Invalidation of any certificate issued to the yacht may result in the withdrawal of the COR.
- .4 The RO shall advise the Administrator promptly, in writing, when it suspends, withdraws, cancels, or alters the operational limitations of its certificates, together with the reason(s) why such action was taken.
- .5 The RO shall promptly inform the Administrator when a yacht is found to be in operation with deficiencies or discrepancies, such that the condition of the yacht or its equipment does not meet the requirements or comply with the particulars of its certificates, the requirements of applicable international conventions, and/or national requirements.

3.3 PAXYs Constructed in Accordance with the Code

See Delegating Yacht Code Compliance Reviews and Surveys for New Construction and Conversions (YTC 2) for the delegation of Yacht Code compliance reviews and surveys of new constructions and conversions of yachts.

4.0 YACHT-SHORE TRANSFER

4.1 Tenders

- .1 A tender shall be fit for its intended use.
- .2 A lifeboat or rescue boat may be utilized as a tender, provided that the craft, equipment, and its launching appliances are certified and in compliance with the LSA Code.
- .3 Safety equipment shall be provided on each tender as appropriate to its intended range and areas of operation. Such safety equipment shall include, but not be limited to, appropriately sized life jackets for each person on board the tender, appropriate radio communications, a portable fire extinguisher, and a mechanical or portable foghorn or klaxon.
- .4 The tender itself shall be clearly marked with the number of persons that it can safely carry and the name of the mother yacht.

- .5 In the case of crafts with gasoline powered engines, the safety requirements for the carriage of gasoline outlined in Chapter II §10.1 of this Code shall be met.
- .6 An official TSC confirming an equivalence of safety shall be issued by an AR. This statement has a validity of five years, subject to required annual surveys being satisfactorily held.
- .7 It is the responsibility of the Master to ensure that the operations of any water craft belonging to the mother yacht of any type are in compliance with the rules and regulations imposed by the local port authorities for the area of operation, including any training as required.

5.0 HELICOPTER AND LANDING FACILITIES

All PAXYs, where helicopter operations to and from the yacht are performed, shall comply with the applicable rules and regulations in accordance with [Annex 2](#) of this Code.

6.0 SUBMERSIBLES

6.1 General Requirements

- .1 All submersibles to be installed on a PAXY shall be designed and built in accordance with the Rules of Class and maintained in Class.
- .2 When installing a submersible, special consideration shall be given to the stability and structure of the yacht.

6.2 Lifting Appliances and Attachments

- .1 The design and construction of the lifting appliance(s) and their attachment to the structure of the yacht and the associated stowage of the submersible shall be in accordance with the Rules of Class or certified as suitable for their intended use.
- .2 Lifting appliances and associated equipment installed on equipment where “man-riding” is required, shall be maintained and tested in accordance with §7.2 of this Chapter.
- .3 Where no “man-riding” is required, the equipment shall be maintained and tested to the recommendations as specified in *Voluntary Compliance with ILO Convention No.152 (TC 3)*.

6.3 Operation

- .1 The safe operation of the submersible is the responsibility of the Master.
- .2 The Master shall ensure that the operator of the submersible has had the proper training and is certified to operate the submersible.
- .3 An operations manual shall be available on board the yacht. The manual shall contain, as a minimum, the lowering and recovery procedures, fire-fighting, and safety procedures and drills.

7.0 SAFE WORKING PRACTICES

7.1 Safe Work Aloft, Over the Side, at Heights, and on the Bowsprit of Sailing PAXYs

- .1 When work aloft, over the side, at heights, or access to the rigging or bowsprit is likely to be an operational necessity, provisions shall be made to enable this work to be performed safely. The arrangements and procedures shall be documented in the SMS to the satisfaction of the Administrator.
- .2 The arrangements and procedures shall be based on a formal risk assessment and on established safe working practices for the type of yacht. The procedures must address issuing a permit to work for each occasion. The arrangements may include, but not be limited to:
 - (a) safety nets below the bowsprit;
 - (b) safety grab-rails (pulpit) fixed along the bowsprit to act as handholds and safety points for safety harnesses;
 - (c) appropriate safety harnesses with a fall arrest device and personal protective equipment (PPE) shall be provided;
 - (d) sufficient footropes permanently rigged to enable the crew to stand on them while working out on the yards or on the bowsprit;
 - (e) safety jackstays (in metal) fixed along the top of the yards, to provide handholds and act as strong points for safety harnesses;
 - (f) fixed static lines for attaching lanyards; and
 - (g) means of safely going aloft, such as:
 - (i) fixed metal steps or ladders with anti-slip surfaces attached to the mast;

- (ii) traditional ratlines; or
 - (iii) bosun's chair.
- .3 The use of "rail and trolley" systems or similar systems for undertaking work over the side is permitted, provided that:
- (a) the systems installed comply with and are certified to the applicable British Standards (BS) 795 and BS 7883 standards for manufacturing, installation and pre- and post-installation testing for Class D Fall Protection Equipment;
 - (b) the systems are installed, maintained, and tested according to the manufacturer's instructions. Testing shall be witnessed by the RO;
 - (c) the operations of these systems are fully described in the SMS manual for safe working practice; and
 - (d) a full risk assessment is performed prior to the work being undertaken and that the crew members and/or contractors working with the equipment are trained and competent for the use of these systems on board.
- .4 Where "rail and trolley" systems are installed, the method of installation to the particular surface and underlying construction (substrate) needs to be tested in accordance with the requirements as per §7.1.3 (a) and (b) above to be considered approved and suitable for supporting crew members working over the side.

If a particular method of attachment of the systems to the substrate has been previously approved and documentary evidence can be provided only post-installation testing shall be required, as below:

- (a) For yachts with existing "rail and trolley" systems:
 - (i) if it cannot be confirmed that the design of the attachment to the substrate is identical to that used in the type approval process completed by the system's manufacturer, or through approval of the design on another vessel, separate pre-installation testing is required to be satisfactorily completed prior to the system being installed; or
 - (ii) if fitted with systems for which there is evidence that the system complies with the BS standards but without evidence that the installation was tested by an approved surveyor, the system shall not be used until the installation arrangements have been approved by the RO; or
 - (iii) if fitted with systems for which there is evidence that the system is in compliance with the BS standard and that the installation was

approved but there is no evidence of post-installation testing, the systems shall be subject to post installation testing.

- (b) For yachts with new “rail and trolley” systems, in addition to the systems requiring type approval, the installation of the system to the substrate of the yacht shall be tested to meet the requirements of the latest edition of the BS standards in force at the time of the installation of the system.

7.2 **Man-Riding Cranes**

Man-riding cranes must meet the following conditions:

.1 Design

Except those deck cranes and davits used for the launching LSA equipment, deck cranes or other lifting appliances must be certified for the purpose of “man-riding” taking the international standards into account. Certification of such appliances shall be carried out to the satisfaction of the RO.

.2 Testing and Maintenance

Annual and five-year testing and maintenance shall be in accordance with the original manufacturer’s instructions.

.3 Operations

Operations of the man-riding cranes and other lifting appliances shall:

- (a) be in accordance with the original equipment manufacturer’s operating instructions; and
- (b) adhere to any restrictions established by the original equipment manufacturer or RO approving the equipment.

The operating instructions shall be part of the SMS and posted locally to any controls along with any restrictions as per [§7.2.3\(b\)](#).

7.3 **Noise and Vibration**

- .1 PAXYs of 1,600 GT and above with a keel lay date on or after 01 January 2015, shall comply with the IMO Code on Noise Levels On Board Ships (Noise Code).
- .2 PAXYs less than 1,600 GT with a keel lay date on or after 01 January 2015, shall meet the requirements of the Noise Code, so far as is reasonable and practicable.

- .3 Noise and vibration in the accommodation spaces shall be limited to the maximum extent possible and in accordance with the Noise Code and with any other relevant international standards as far as is reasonable and practicable.
- .4 Accommodation, recreational, and catering facilities shall be located as far as is reasonable and practicable from the engines, steering gear rooms, deck winches, ventilation, heating and air-conditioning equipment, and other noisy machinery.
- .5 Acoustic insulation or other appropriate sound-absorbing materials shall be used in the construction and finishing of bulkheads, deck heads, and decks within the sound-producing spaces as well as self-closing noise-isolating doors for machinery spaces.

7.4 Training Manual

- .1 The training manual shall include details of established safe working practices specific to the yacht, as well as guidance on:
 - (a) training for members of the crew;
 - (b) personal clothing and protection from injury;
 - (c) health and safety awareness;
 - (d) prevention of pollution; and
 - (e) life-saving appliances and fire-fighting equipment.
- .2 The training manual shall be yacht type specific and contain instructions for the actual equipment brands/types on board. The information in regard to the life-saving appliances and fire-fighting equipment provided on the yacht and the best methods of survival shall be explained in easily understood terms and illustrations, where appropriate (reference should be made to SOLAS III/35, and SOLAS II-2/15).
- .3 The training manual shall be written in the working language of the yacht and in English.
- .4 The Master shall conduct drills and/or trainings for the crew. Refer to RMI Maritime Regulations ([MI-108](#)), regulation §7.41, as applicable. The drills and/or trainings shall also be documented in the SMS manual.

7.5 Instructions for Onboard Maintenance

Instructions shall be provided describing the maintenance procedures for all safety and fire-fighting appliances in easily understood terms and illustrated wherever possible.

Refer to *Life-Saving Appliances and Systems* ([MN 2-011-37](#)) and *Maintenance and Inspection of Fire Protection Systems and Appliances* ([MN 2-011-14](#)).

7.6 Safety Management System

All PAXYs regardless of gross tonnage shall comply to the requirements of §[1.11](#) of this Chapter in regard to SMS.

7.7 Maritime Security

All PAXYs regardless of gross tonnage shall comply to the requirements of §[1.12](#) of this Chapter in regard to ISPS Code requirements and SOLAS XI-2.

8.0 PASSENGERS

8.1 Limitations

- .1 PAXYs shall carry no more than 36 passengers regardless of the number of beds or berths provided.
- .2 PAXYs may apply to the Administrator for a temporary authorization to carry more passengers, on an excursion of very limited duration and range, during which no additional passenger would be berthed on board for an overnight passage. In order to apply for such a dispensation, the owner or Master may request an *Application for Temporary Dispensation to Carry Additional Persons On Board* ([YTEC-01](#)) from the Administrator.

9.0 MANNING

9.1 Minimum Safe Manning

Refer to *Minimum Safe Manning Requirements for Vessels* ([MN 7-038-2](#)) for yacht minimum safe manning requirements.

9.2 Crew Certification

For information on crew certification refer to *Requirements for Seafarer Certification* ([MI-118](#)), §7.0.

CHAPTER IV:
PRIVATE YACHTS LIMITED CHARTER (PYLCs)

1.0 STATUTORY AND NATIONAL REQUIREMENTS

All PYLCs¹² shall comply with the requirements outlined in this Chapter IV, as well as the applicable requirements of [Chapter I](#) of this Code and all other applicable RMI laws and regulations.

Refer to *RMI Yacht Compliance Requirements* ([MI-103A](#)) for a comprehensive matrix of statutory and national requirements.

1.1 **Convention on the International Regulations for Preventing Collisions at Sea, 1972 (COLREGS '72)**

All yachts shall comply with the requirements of COLREGS '72.

1.2 **International Convention on Tonnage Measurement of Ships, 1969 (ITC)**

All yachts of 24 m or more in length are required to be surveyed and admeasured to the ITC and issued with an International Tonnage Certificate.

1.3 **International Convention for the Prevention of Pollution from Ships (MARPOL)**

All yachts are required to comply with the provisions of MARPOL, subject to the applicability of each MARPOL Annex.

MARPOL electronic record and logbooks are permitted to be used. They shall be approved by the Administrator where required by international convention. See *Electronic Record Books and Logbook Systems* ([MN 7-041-5](#)).

Refer to *Requirements for MARPOL Surveys for All Yachts* ([MN 2-013-11](#)).

1.3.1 **MARPOL Annex I**

All yachts shall comply with the requirements of MARPOL Annex I. Yachts of 400 GT and above shall be surveyed to verify compliance and issued with the following:

- (a) International Oil Pollution Prevention Certificate; and
- (b) Supplement to the International Oil Pollution Prevention Certificate; and shall maintain
- (c) an Oil Record Book (ORB)*

**All yachts less than 400 GT shall maintain a similar ORB.*

¹² The general term “yacht” when used throughout this Chapter shall mean a PYLC.

1.3.2 MARPOL Annex IV

- .1 Yachts of 400 GT and above or certified to carry more than 15 persons, regardless of tonnage, shall comply with the requirements of MARPOL Annex IV. Yachts to which Annex IV applies, shall be surveyed to verify compliance and issued with an International Sewage Pollution Prevention Certificate.
- .2 In certain cases, MARPOL Annex IV stipulates criteria for “ships ...which are certified to carry more than 15 persons.” The Administrator recognizes that this is not always applicable to all yachts due to non-mandatory requirements of certain certificates.
- .3 Therefore, for the purposes of MARPOL Annex IV, where the number of persons carried on board is a stipulated criterion, the figure to be used shall be that number shown on the *Record of Safety Equipment – Form E* (MI-289).

1.3.3 MARPOL Annex V

- .1 All yachts shall comply with the requirements of MARPOL Annex V. Yachts of 400 GT and above and those certified to carry 15 persons or more, regardless of tonnage, shall be surveyed to verify compliance and must maintain a Garbage Record Book.
- .2 All yachts of 100 GT and above or certified to carry 15 persons or more, regardless of tonnage, are required to have a Garbage Management Plan.
- .3 In certain cases, MARPOL Annex V stipulates criteria for “every ship ...which is certified to carry 15 or more persons.” The Administrator recognizes that this is not always applicable to all yachts due to non-mandatory requirements of certain certificates.

Therefore, for the purposes of MARPOL Annex V, where the number of persons carried on board is a stipulated criterion, the figure to be used shall be that number shown on the *Record of Safety Equipment – Form E* (MI-289).

1.3.4 MARPOL Annex VI

All yachts shall comply with the requirements of MARPOL Annex VI. yachts of 400 GT and above are required to be surveyed to verify compliance and be issued with the following:

- (a) International Air Pollution Prevention Certificate (IAPPC); and
- (b) Supplement to the IAPPC; and maintain an
- (c) Ozone-Depleting Substances Record Book; and

- (d) International Energy Efficiency Certificate (IEEC); and
- (e) Ship Energy Efficiency Management Plan (SEEMP).
- (f) In addition, PYLCs that are required to comply with Regulation 13 of Annex VI shall have an Engine Technical File and an Engine IAPPC (EIAPPC) for each marine diesel engine over 130 kW.

1.4 **Anti-Fouling**

- .1 All yachts shall comply with the requirements of the International Convention on the Control of Harmful Anti-fouling Systems on Ships. All yachts of 400 GT and over and engaged in international voyages shall be issued with the following:
 - (a) International Anti-fouling System Certificate; and
 - (b) Record of Anti-fouling Systems.
- .2 yachts of 24 m or more in length but less than 400 GT engaged in international voyages shall carry a Declaration on Anti-fouling Systems signed by the owner or their representative. The Declaration shall be accompanied by appropriate documentation such.

1.5 **International Convention for the Control and Management of Ships' Ballast Water and Sediments, 2004 (BWM Convention)**

All yachts constructed to carry ballast water shall comply with the requirements of the BWM Convention. Equivalent compliance with the BWM Convention for yachts used solely for recreation or competition less than 50 m in length overall and with a maximum ballast water capacity of 8 m³ shall be determined by the Administrator in accordance with Regulation A-5 of the BWM Convention, taking into account any guidelines developed by the IMO.

1.6 **Nairobi International Convention on the Removal of Wrecks, 2007 (WRLC)**

All yachts of 300 GT and above are required to be insured and certificated under the WRLC. Refer to *Nairobi International Convention on the Removal of Wrecks, 2007 Certification Requirements* ([MN 2-011-45](#)).

1.7 **Standards of Training, Certification and Watchkeeping for Seafarers, 1978 (STCW)**

All yachts that are 24 m in length and above and/or 80 GT and above shall have an MSMC and the crew must be appropriately certified in accordance with [§21.0](#) of this Chapter.

1.8 International Code of Safety for Ships using Gases or other Low-Flashpoint Fuels (IGF) Code

Where low-flashpoint fuel is used for propulsion machinery, auxiliary power generation machinery, and/or other purpose machinery, the requirements of the IGF Code shall be applicable for all yachts:

- (a) for which the building contract is placed on or after 1 January 2017; or
- (b) in the absence of a building contract, the keels of which were laid or which were at a similar stage of construction on or after 1 July 2017; or
- (c) the delivery of which is on or after 1 January 2021

2.0 CONVENTION SURVEYS

2.1 Survey Standards

- .1 Statutory and other certification work may be undertaken by those organizations specified in *Organizations Acting on Behalf of the Republic of the Marshall Islands Maritime Administrator* ([MG 2-11-15](#)).
- .2 Further, those entities authorized by ROs to conduct in water surveys, radio surveys, etc., are also duly recognized by the Administrator.

2.2 Survey Requests

All requests for survey and certification must be made to an appropriate RO.

2.3 Statements of International Convention Voluntary Compliance

Those yachts that voluntarily comply with the provisions of an international convention or code, which would not otherwise apply to the particular yacht, shall have Statements of International Convention Voluntary Compliance issued instead of convention certificates of compliance.

3.0 MAINTAINING COMPLIANCE WITH THIS CODE

3.1 General

In accordance with RMI laws and regulations, all PYLCs shall be inspected annually by an AR to verify compliance with the Code. This Compliance Verification is in

addition to, and separate from, any other inspections or surveys that may be required to meet Class or international statutory requirements.

See *Surveys and Issuance of International Convention and National Certificates for Yachts* ([MN 2-011-54](#)) for further instructions on compliance verification requirements.

3.2 Statutory Compliance and RMI Certification

Every yacht shall maintain valid statutory international convention certification issued by an RO and must also maintain a valid RMI PYLC Compliance Certificate (PYLCCC).

- .1 Classed yachts shall be certified for compliance to the international statutory conventions by a Classification Society.
- .2 Unclassed yachts may be certified for compliance to the international statutory conventions by an AR.
- .3 Unclassed yachts shall have the outside of the yacht's bottom and related items examined in accordance with *Examination of a Yacht's Hull and Related Items* ([YTC 4](#)).
- .4 It shall be the responsibility of owners/managers and Masters to ensure that their PYLCs are in compliance with the requirements of all applicable international treaties, conventions, protocols, codes, and agreements which have come into force and to which the RMI is a party.
- .5 It is the responsibility of the owner/manager and Master to maintain the validity and endorsement of all applicable certificates at all times. Invalidation of any certificate issued to the yacht may result in the withdrawal of the COR.
- .6 The RO shall advise the Administrator promptly, in writing, when it suspends, withdraws, cancels, or alters the operational limitations of its certificates, together with the reason(s) why such action was taken.
- .7 The RO shall promptly inform the Administrator when a yacht is found to be in operation with deficiencies or discrepancies, such that the condition of the yacht or its equipment does not meet the requirements or comply with the particulars of its certificates, the applicable international conventions, and/or RMI requirements.

3.3 PYLCs Constructed in Accordance with the Code

See *Delegation of Yacht Code Compliance Reviews and Surveys of New Construction and Conversion of Yachts (YTC 2)* for the delegation of Yacht Code compliance reviews and surveys of new constructions and conversions of PYLCs.

4.0 CONDITIONS OF ASSIGNMENT

4.1 General

- .1 Yachts shall comply with the Conditions of Assignment in Chapter II of the ILLC, as amended by this Code, unless specified otherwise.
- .2 In individual cases, when the requirements of ILLC or the Code cannot be met, the Administrator may consider alternative arrangements to achieve adequate safety standards, such as, imposing operational limitations.

4.2 Hatchways and Skylight Hatches

4.2.1 General requirements

- .1 All openings leading to spaces below the weather deck not capable of being closed weather-tight must be enclosed within either an enclosed superstructure or a weather-tight deckhouse of adequate strength.
- .2 All exposed hatchways which give access to spaces below the weather-tight weather deck are to be of substantial weather-tight construction and provided with efficient means of closure. Weather-tight hatch covers shall be permanently attached to the yacht and provided with adequate arrangements for securing the hatch closed.
- .3 Hatches that are to be used for escape purposes shall be provided with covers that are capable of being opened from both sides. An escape hatch shall be readily identifiable and easy and safe to use, having due regard to its position and access to and from the hatch.
- .4 Flush deck hatches are acceptable for escape hatches and lockers on deck, if constructed to the Rules of Class. Wells for rescue boats with flush hatches are acceptable provided they meet the Rules of Class.

4.2.2 Hatchways Open at Sea

Hatches should be kept closed at sea. However, hatchways that may be kept open for access at sea for lengthy periods are to be kept as small as is practical (a maximum of 1 m² in a clear area), located on the centerline of the yacht, and fitted with coamings in accordance with the Tables in §4.3 below. These coamings do not need to exceed

300mm. Covers of hatchways are to be permanently attached to the hatch coamings and, where hinged, the hinges are to be located on the forward side. Alarm switches should be installed that indicate the open/close position of the hatches in the wheelhouse.

4.3 Doorways and Companionways Located Above the Weather Deck for PYLCs Category 0 and 1

- .1 Exposed doors in deckhouses and superstructures that give access to spaces below the weather deck are to be weather-tight, and door openings shall have coaming heights in accordance with Table 17 below:

Table 17

Location	Category 0	Category 1
a	600 mm	300 mm
b	300 mm	150 mm
c	150 mm	75 mm

Location:

- a if the door is in the forward quarter length of the PYLC and used when the yacht is at sea;
 - b if the door is in an exposed forward-facing location aft of the forward quarter length; or
 - c if above the surface of the deck when the door is in a protected location aft of the forward quarter length or an unprotected door on the first-tier deck above the weather deck.
- .2 Exposed doors installed in location c per §4.3.1 may use a water freeing well in lieu of a coaming. The size of the well shall provide an equivalent level of prevention of water ingress to the satisfaction of the RO.
- .3 Weather-tight doors shall be so arranged to open outwards and when located in the side of the house, shall be hinged at the forward edge. Alternative closing arrangements may be considered if it can be demonstrated that the efficiency of the closing arrangements and their ability to prevent the ingress of water will not impair the safety of the yacht.
- .4 An access door leading directly to the engine room from the weather deck shall be fitted with a coaming height in accordance with Table 18 below:

Table 18

Location*	Category 0	Category 1
Position 1	600 mm	450 mm
Position 2	380 mm	200 mm

* Positions as defined as per ILLC

- .5 Coaming heights, construction, and securing standards for weather-tight doors that are provided for use only when the yacht is in port or at anchor in calm sheltered waters and are locked closed when the yacht is at sea may be considered individually.
- .6 Companion hatch openings:
 - (a) Companionway hatch openings that give access to spaces below the weather deck shall be fitted with a coaming, the top of which is at least 300 mm above the deck. Yachts of Category 2 shall have a coaming of at least 150 mm above the deck.
 - (b) Washboards may be used to close the vertical opening. When washboards are used, they shall be so arranged and fitted that they will not be dislodged readily. Provisions are to be made to ensure that they are stowed in a secure location when not in use.
 - (c) The maximum breadth of an opening in a companion hatch shall not exceed 1 m.

4.4 Skylights for PYLCs Category 0 and 1

- .1 All skylights shall be of efficient weather-tight construction approved by the RO. The location of the skylights shall be on or as near to the centerline of the yacht as practicable.
- .2 Skylights of the opening type shall be provided with efficient means for securing the skylight in the closed position.
- .3 A minimum of one portable cover for each size of glazed opening shall be provided which can be accessed rapidly and efficiently secured in the event of a breakage of a skylight.
- .4 Skylights that are provided as a means of escape shall be operable by hand from both sides. An escape skylight shall be readily identified and easy and safe to use, having due regard to its position and to the access to and from the skylight. Portable covers for these skylights shall be able to be opened from the inside to enable escape to the outside in case of emergency.
- .5 The skylight glazing material shall be in accordance with the requirements of glazed openings of §4.5 below.

4.5 Glazed Openings

- .1 Glazed openings shall:
 - (a) be made of toughened safety glass;
 - (b) be of strength appropriate to their location in the yacht and meet the Rules of Class or a recognized national or international standard such as ISO 11336-1:2012(E);
 - (c) be substantially framed and efficiently secured to the structure;
 - (d) shall not be fitted in way of machinery spaces; and
 - (e) be of non-readily opening type.
- .2 Where glazed openings are fitted by bonding, the bonding agent(s) are to be of an approved type.
- .3 Glazed openings that are fitted:
 - (a) below the freeboard deck or protect buoyant volumes shall:
 - (i) have a sill height at least 500 mm or 2.5% of the breadth of the yacht whichever is the greater above the smallest freeboard assigned; and
 - (ii) shall be provided with a deadlight which is to be permanently attached and effectively closed and secured watertight in the event of a breakage of the glazing. Proposals to fit portable deadlights will be subject to special consideration and approval by the Administrator, having regard for the location of the glazed openings and ready availability of deadlights to be fitted.
 - (b) in the first tier front and sides of enclosed superstructures or second tier front of enclosed superstructures on a yacht of Category 0 or 1 shall be:
 - (i) fitted with storm covers; or
 - (ii) where glazing thickness is increased to an equivalent strength of a storm cover, a blanking plate shall be provided for each opening size.
- .4 Regular inspections of glazing shall include, but should not be limited to:
 - (a) the surface of the glazing; and
 - (b) bonded glazed openings with respect to the bond line and any deterioration.

- .5 Glazed openings in way of the conning position shall comply with the requirements of §12.4 below.

4.6 Ventilators and Exhausts for PYLCs Category 0 and 1

- .1 Adequate natural and/or mechanical ventilation is to be provided throughout the yacht. The accommodation spaces are to be protected from the entry of gas and/or vapor fumes from galley, machinery, exhaust, and fuel systems.
- .2 Ventilators in exposed locations are to be of efficient construction and provided with permanently attached means of weather-tight closure. Ventilators serving any space below the freeboard deck or an enclosed superstructure shall have coamings of minimum heights as specified in Table 19 below:

Table 19

Location	Category 0	Category 1
Forward Quarter Length	900 mm	450 mm
Elsewhere	760 mm	380 mm

- .3 Ventilators shall be kept as far inboard as practicable and the height above the deck of the ventilator opening shall be sufficient to prevent the ingress of water when the yacht heels.
- .4 The ventilation of spaces, such as the machinery space, that must remain open require special attention with regard to the location and height of the ventilation openings above the deck taking into account the effect of the down-flooding angle on stability standard.
- .5 The means of closure of ventilators serving the machinery space shall be selected with regard to the fire protection and extinguishing arrangements provided in the machinery space.
- .6 Engine exhaust outlets that penetrate the hull below the freeboard deck shall be provided with means to prevent back-flooding into the hull through a damaged exhaust system. Yachts of Category 0 and of 24 m or more in length shall have a means of positive closure where the outboard side is an equivalent construction to the hull. All other yachts, at a minimum, shall have well-constructed anti-siphon loops on all exhaust lines at a minimum height of 1 m above the waterline or a satisfactory waterbreak system.

4.7 Air Pipes for PYLCs Category 0 and 1

- .1 Air pipes serving fuel and other tanks shall be of efficient construction and provided with permanently attached means of weather-tight closure. Means of

closure may be omitted if it can be shown that the open end of an air pipe is protected by other structures that will prevent the ingress of water.

- .2 Where located on the weather deck, air pipes shall be kept as far inboard as practicable and be fitted with a coaming of sufficient height to prevent inadvertent flooding. Where this is impractical to do so, air pipes may be fitted in a suitable protected area elsewhere, provided that this location is to the satisfaction of the RO. Air pipes to tanks should have coamings of minimum heights as specified in Table 20 below:

Table 20

Location	Category 0	Category 1
On Weather Deck	760 mm	380 mm
Elsewhere	450 mm	225 mm

- .3 Air pipes to fuel tanks shall terminate at a height of not less than 760 mm above either the top of the filler pipe for a gravity filling tank or the top of the overflow tank for a pressure filling tank.

4.8 Scuppers, Sea Inlets, and Discharges

The standards of the ILLC shall be applied to every discharge led through the shell of the yacht. All sea inlet and overboard discharges shall be provided with efficient shut-off valves arranged in positions where they are readily accessible at all times.

4.9 Materials for Valves and Associated Piping

- .1 Valves that are fitted below the waterline shall be of steel, bronze, or other material having a similar resistance to impact and fire.
- .2 The associated piping shall, in areas as indicated above, be of steel, bronze, copper, or other equivalent material that is considered of equal or greater strength than the hull.
- .3 Where the use of plastic piping is proposed, it will be considered on an individual basis and full details of the type of piping and its intended location and use shall be submitted to the Administrator for consideration. The Administrator may require tests to be carried out on the plastic piping, as necessary, before approving its use.
- .4 The use of flexible piping in any situation should be kept to a minimum compatible with the essential reason for its use. The RO shall approve flexible piping and the means of joining it to its associated hard piping system as fit for the purpose.

4.10 Underwater Lights

Underwater lights and their installation shall be approved by the RO.

4.11 Water Freeing Arrangements for PYLCs Category 0 and 1

- .1 The standards for water freeing arrangements shall comply with the ILLC. In individual cases when the requirements of the ILLC cannot be met, the Administrator may consider alternative arrangements to achieve adequate safety standards, such as, operational limitations. In any case, the intention should be to achieve a standard of safety that is at least equivalent to the standard of the ILLC.
- .2 When a yacht is unable to fully comply with the ILLC, the Administrator may take into account the yacht's past performance in service and the declared area(s) of operation and assign a limited range Category 1. This notation will be recorded on the PYLCCC, as applicable.
- .3 Recesses on a PYLC:
 - (a) any recess in the weather deck shall be of weather-tight construction and shall be self-draining under all normal conditions of heel and trim of the yacht;
 - (b) an open swimming pool or spa shall be treated as a recess;
 - (c) the recess drainage arrangement shall be capable of efficient operation when the PYLC is heeled at an angle of 10° for a motor PYLC and 30° for a sailing PYLC;
 - (d) the drainage arrangement shall be such as to be able to empty the full recess within three minutes when a yacht is in a normal seagoing condition and to prevent the backflow of water into the recess; and
 - (e) any alternative arrangements proposed for consideration by the Administrator should take into account the mass of water and its free surface effect on the intact and damage stability.

4.12 Bulwarks and Guard Rails

Yachts shall comply with the ILLC requirements, unless compliance is unreasonable or not practicable.

- .1 Where there will be people on the deck frequently, bulwarks or three courses of rail or taut wires shall be fitted around the deck at a height of not less than 1 m from the deck. Guard rails or taut wires when used shall be supported by

stanchions at intervals not exceeding 2.2 m. Intermediate courses of rails or wires shall be evenly spaced.

- .2 Where the function of the yacht would be impeded by the provision of bulwarks and/or guard rails complying with §4.12 alternative proposals detailed to provide an equivalent level of safety for persons on deck may be submitted to the Administrator for review and approval.
- .3 Glazed bulwarks may be used provided they are constructed and installed to the satisfaction of the RO or a recognized national or international standard.

4.13 General Equivalence

Where yachts cannot comply with the requirements of §4.2 to §4.12 above, equivalent arrangements may be considered by the Administrator. Such proposals should take into account the following non-exhaustive list:

- (a) closure at sea;
- (b) enhanced bilge pumping capacity and bilge alarms;
- (c) full compliance with damage stability;
- (d) provision of dorade boxes or baffle systems to prevent direct water ingress;
- (e) alternative ventilation for use in bad weather;
- (f) excess freeboard – greater than one standard superstructure height;
- (g) consideration of risk of down-flooding angle and height due to position;
- (h) consideration of risk of green sea loads;
- (i) enhanced survey inspection regime; and
- (j) operational limitations.

5.0 STABILITY – INTACT AND DAMAGED

5.1 General

- .1 Yachts assigned Category 0 or 1 shall comply with §5.1 to §5.6 below as part of the Conditions of Assignment.

- .2 Yachts of Category 2 that carry an approved stability book shall comply with §5.1 to §5.6.
- .3 An intact stability standard proposed for assessment of the yacht configuration, which is not covered by this Code, shall be submitted to the RO for review at the earliest opportunity.
- .4 Permanent ballast used onboard a yacht shall be located and installed to the requirements of the RO. Permanent ballast shall be installed as such that prevents shifting of position and shall not be removed from the yacht or relocated within the yacht without the approval of the RO. Permanent ballast particulars shall be noted in the stability booklet. Local or global hull strength requirements for the installation of additional ballast shall be assessed.

5.2 **Intact Stability**

5.2.1 **Motor Yachts**

The statical stability curves for seagoing conditions shall meet the following criteria:

- (a) the area under the righting lever (GZ) curve shall not be less than 0.055 meter-radians up to $\phi=30^\circ$ angle of heel and not less than 0.09 meter-radians up to $\phi=40^\circ$ angle of heel, or the angle of down-flooding ϕ_f ¹³, if this angle is less than 40° ; additionally, the area under the GZ curve between the angles of heel of 30° and 40° or between 30° and the angle of down-flooding ϕ_f , if this angle is less than 40° , shall not be less than 0.03 meter-radians;
- (b) the GZ shall be at least 0.20 m at an angle of heel equal to or greater than 30° ;
- (c) the maximum GZ shall occur at an angle of heel not less than 25° ;
- (d) after correction for free surface effects, the initial metacentric height (GM) shall not be less than 0.15 m; and
- (e) in the event that the yacht's intact stability standard fails to comply with the criteria defined in §5.2.1a to §5.2.1d above, the equivalent stability standards of §5.2.2. below may be considered by the Administrator as recommended by the RO.

¹³ ϕ_f is an angle of heel at which openings in the hull, superstructures, or deck-houses which cannot be closed weather-tight immerse. In applying this criterion, small openings through which progressive flooding cannot take place need not be considered as open.

5.2.2 Equivalent Stability Standards

Where motor yachts are unable to meet the criteria in §5.2.1 above, the following criteria may be used:

- (a) the area under the GZ curve shall not be less than 0.07 meter-radians up to 15° angle of heel, when maximum GZ occurs at 15°, and 0.055 meter-radians up to 30° angle of heel, when maximum GZ occurs at 30° or above. Where the maximum GZ occurs at angles of between 15° and 30°, the corresponding area under the GZ curve shall be:

$$0.055 + 0.001(30^\circ - \varphi_{\max}) \text{ meter-radians};^{14}$$

- (b) the area under the GZ curve between the angles of heel of 30° and 40°, or between 30° and the angle of down-flooding (φ_f) if this is less than 40°, shall not be less than 0.03 meter-radians;
- (c) the GZ shall be at least 0.20 m at an angle of heel equal to or greater than 30°;
- (d) the maximum GZ shall occur at an angle of heel not less than 15°; and
- (e) after correction for free surface effects, the GM shall not be less than 0.15 m.

5.2.3 High Speed Yachts

Yachts capable of attaining higher speeds or planing shall also take into consideration the characteristics of these hull forms, including but not limited to directional instability, bow diving, reduction of transverse stability, porpoising, and chine tripping.

5.2.4 Sailing Yachts

Sailing yacht stability shall be considered on a case-by-case basis by the RO.

5.3 Damaged Stability

- .1 Damage stability shall be applied to all yachts as an equivalency for non-compliance with full ILLC Conditions of Assignment.
- .2 Therefore, damage stability is not applicable to yachts that obtain full compliance with the ILLC Conditions of Assignment.
- .3 The watertight bulkheads of the yacht shall be so arranged that minor hull damage that results in the free flooding of any one compartment, will cause the yacht to

¹⁴ φ_{\max} is the angle of heel in degrees at which the GZ curve reaches its maximum.

float at a waterline which, at any point, is not less than 75 mm below the weather deck, freeboard deck, or bulkhead deck, if not concurrent.

- .4 Minor damage shall be assumed to occur anywhere in the length of the yacht, but not on a watertight bulkhead (transverse or longitudinal).
- .5 Standard permeabilities shall be used in this assessment, as outlined in Table 21 below:

Table 21

Space	Percentage Permeability
Stores	60
Stores but not a substantial quantity thereof	95
Accommodation	95
Machinery	85
Liquids	95 or 0 whichever results in the more onerous requirements

- .6 In the damaged condition, the residual stability shall be such that any angle of equilibrium does not exceed 7° from the upright, the resulting GZ curve has a range to the down-flooding angle of at least 15° beyond any angle of equilibrium, the maximum righting lever within that range is not less than 100 mm, and the area under the GZ curve is not less than 0.015 meter-radians.

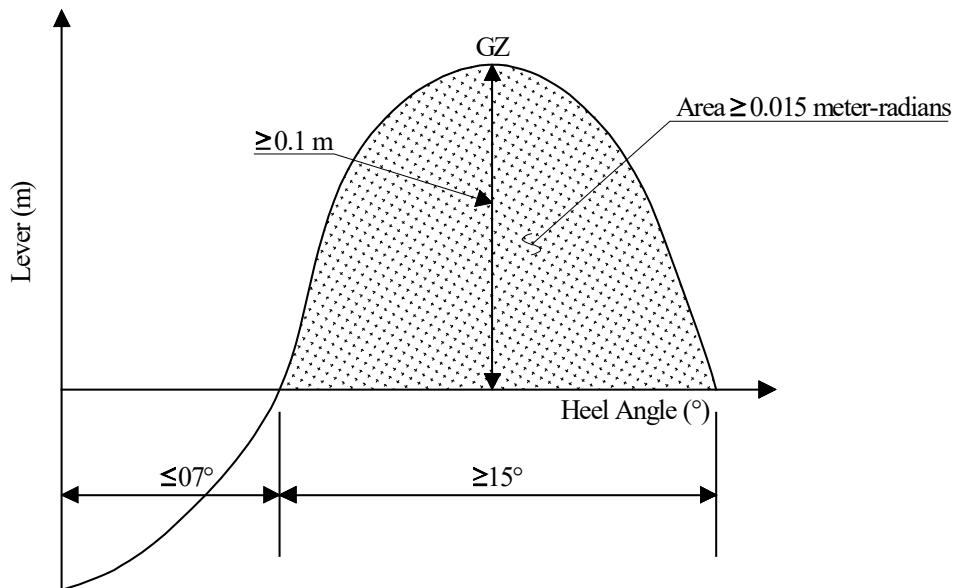

5.4 Elements of Stability

- .1 The lightship displacement, vertical center of gravity (KG), and longitudinal center of gravity of a yacht shall be determined from the results of an inclining experiment.
- .2 An inclining experiment shall be conducted in accordance with a detailed standard as well as a specific test procedure that is approved by the RO. In addition, the experiment shall be conducted in the presence of the RO.
- .3 The report of the inclining experiment and the lightship particulars derived shall be approved by the RO.
- .4 At the discretion of the owner(s) or managing agent(s), and prior to approval of the lightship particulars by the RO, a margin for safety may be applied to the lightship displacement and KG calculated after the inclining experiment.
- .5 Such a margin shall be clearly identified and recorded in the stability booklet.
- .6 A formal record shall be kept in the stability booklet of alterations or modifications to the yacht which affect lightship displacement, vertical KGs and/or longitudinal center of gravity (LCG).
- .7 When sister yachts are built at the same shipyard, the RO may accept lightweight check on subsequent yachts to corroborate the results of the inclining experiment conducted on the lead yacht of the class.

5.5 Stability Documents

- .1 Yachts (Category 0 and 1) shall be provided with a stability booklet for the Master that is approved by the RO, which contains sufficient information to enable the Master to operate the yacht in compliance with the applicable requirements contained in the Code.
- .2 The stability booklet shall take into account the additional guidelines in accordance with the IS Code Part B, Chapter 3, sections:
 - (a) 3.1 – Effect of free surfaces of liquid in tanks;
 - (b) 3.2 – Permanent ballast;
 - (c) 3.3 – Assessment of compliance with stability criteria;
 - (d) 3.4 – Standard conditions of loading to be examined;
 - (e) 3.5 – Calculation of stability curves; and
 - (f) 3.6 – Stability booklet.

- .3 Sailing yachts shall have a copy of the *Curves of Maximum Steady Heel Angle to Prevent Down-flooding in Squalls* placed in a suitable position for the ready reference of the crew. This shall be a direct copy taken from that contained in the approved stability booklet.
- .4 For yachts where the damage stability has not been assessed, the following note shall be added to the approved stability booklet:

“This yacht has not been assessed for damage stability, and therefore might not remain afloat in the event of damage or flooding.”

5.6 Major Refit or Alterations

- .1 A yacht with previously approved stability information, which undergoes a major refit or major alterations, shall be subjected to re-inclining, in accordance with §5.4 above, and a reassessment of the stability booklet.
- .2 Changes in a yacht’s buoyancy (such as a stern extension) which results in a calculated change in displaced volume of more than 2%, shall require a complete reassessment of stability and newly approved stability information booklets.
- .3 Reconfiguration of the tank arrangement shall require a revision of the yacht’s stability booklet.
- .4 A lightweight survey shall be carried out at an interval not exceeding five years, unless it can be clearly demonstrated that no major change has occurred.
- .5 Notwithstanding §5.6.4 above, a yacht shall undergo a lightweight survey every 10 years.
- .6 The yacht shall be re-inclined whenever, in comparison with the approved stability information, a deviation from the lightship displacement exceeding 2% or a deviation of the lightship LCG exceeding 1% is found or anticipated.

6.0 SAILING YACHT RIGGING

6.1 General

- .1 The condition of the rigging shall be monitored in accordance with a planned maintenance manual and schedule, approved by the RO. The schedule shall include, in particular, regular monitoring of all the gear associated with safe work aloft and on the bowsprit (see [§27.1](#)).

- .2 The overall sail area and spar weights and dimensions shall be documented in the stability information book. Modifications that increase sail area and/or weights and dimensions must be reflected in an approved updating of the stability information booklet.
- .3 All equipment items used for standing rigging, including loose items of gear such as shackles, bottle screws, sheaves, etc. are to be tested and periodically surveyed by a Classification Society that has rules for such equipment.

6.2 Masts and Spars

- .1 Dimensions and materials of the masts and spars shall be certified as being in accordance with the rules or recommendations of a Classification Society or an internationally recognized standard.
- .2 The associated structure for masts and spars (including fittings, decks, and floors) shall be certified as being constructed as to absorb the forces involved.

6.3 Running and Standing Rigging

Running and standing rigging shall meet the following requirements:

- (a) wire rope used for standing rigging (stays or shrouds) is not to be flexible wire rope (fiber rope core);
- (b) the strength of all blocks, shackles, rigging screws, cleats and associated fittings, and attachment points shall exceed the breaking strength of the associated running or standing rigging; and
- (c) chainplates for standing rigging shall be constructed to support and absorb the forces involved. Only one shroud or stay should load an individual attachment point, unless the approved design specifically allows for more.

6.4 Sails

- .1 Adequate means of reefing or shortening sail shall be provided.
- .2 Category 0 and Category 1 yachts shall either be provided with separate storm sails or have specific sails designated and constructed to act as storm canvas.

7.0 FIRE SAFETY AND PREVENTION

7.1 Stowage of Gasoline, Aviation Fuel, and Other Highly Flammable Liquids

The following apply to ensure for the safe stowage of gasoline, aviation fuel, and other highly flammable liquids having a flash point of less than 60° Celsius (C) (herein referred to as “flammable liquids”) that may be carried in portable container(s), permanently fitted tank(s), or other methods.

7.1.1 Portable containers including portable tanks

- .1 Portable containers shall not be stored at a location which is exposed to the environment. Weather conditions, sea state, wind force, etc., are to be taken into consideration.
- .2 Portable containers shall be kept to a minimum, containing no more than 150 L of flammable liquids in total. Means of carriage to consider for portable containers or tanks may be:
 - (a) recessed stowage with overboard chutes;
 - (b) lockers on deck, fully ventilated and with a fixed fire suppression system;
or
 - (c) internal lockers with a fixed fire suppression system.

Such locations shall be clearly marked to identify that flammable liquids are contained within.

- .3 Portable containers used for the carriage of flammable liquids shall be constructed to a recognized standard that is appropriate to the type of flammable liquid to be carried. Additionally, each container shall be clearly marked to indicate its contents.

7.1.2 Permanent Tanks

- .1 Yachts fitted with storage tanks for aviation fuel shall comply with the requirements of *The Civil Aviation Authority’s Standards for Offshore Helicopter Landing Areas* (CAP 437) Chapter 7 and in accordance with the Rules of Class.
- .2 Yachts fitted with permanent tanks for the carriage of flammable liquids, other than in §7.1.2.1 above, shall comply to the below requirements in §7.1.2.3 through §7.1.2.16 below.
- .3 The design, construction, and material of the permanent installed tank shall comply with the Rules of Class.

- .4 Tanks shall be explosion protected, ventilate to a safe environment, and prevent the risk of overpressure and fire/explosion. A vapor recovery system shall be considered.
- .5 High-level alarm systems to warn the crew of overfilling the tank(s) and for remote tank level monitoring shall be provided. The remote measuring must be capable of monitoring outside the tank space. Gauge glasses are not permitted.
- .6 Tanks shall be located in a purposely built gas tight compartment. This space shall only be used for the installation of the storage tank(s) and associated equipment for fuel transfer to and from the tank. Permanently fixed tanks shall not be installed:
 - (a) within Category A machinery spaces;
 - (b) under sleeping accommodations;
 - (c) forward of the collision bulkhead;
 - (d) less than B/5 from ship side;
 - (e) less than 760 mm from bottom plating; and
 - (f) adjacent to the aft end of the hull.
- .7 The purposely built space in which the tank is located shall have gas-tight boundaries to adjacent spaces and be insulated to class "A-60".
- .8 The compartment shall be provided with an addressable fire detection system and a fire suppression system in accordance with §7.7.
- .9 A ventilation system for the compartment shall be provided in accordance with §7.1.3.3 and the ventilation exhaust shall be provided with flame arresting protection as required by IMO Circular MSC/Circ.677, *Revised Standards for the Design, Testing and Locating of Devices to Prevent the Passage of Flame into Cargo Tanks in Tankers*, as amended by IMO Circulars [MSC.1/Circ.1009](#) and [MSC.1/Circ.1324](#)
- .10 A water drainage system within the space shall be provided and capable of removing no less than 125% of the water capacity from the required fire-suppression systems, and be independent from any other drainage or bilge system. If the stability requirements are met in the event of the tank space being completely filled with water, the drainage system can be less than the capacity of the required fire suppression system.

- .11 A suitable gas detection system shall be provided within the compartment, with audible and visual alarm on the bridge and where the crew can be easily alerted.
- .12 Electrical equipment, including fixed and portable lighting, for use in the tank space and within the hazardous zone areas shall be kept to a minimum and shall be certified safe for petrol vapors. The electrical equipment and installation shall be to the rules of the RO.
- .13 Petrol system piping shall be to the rules of the RO. They shall not lead directly through accommodation or Category A machinery spaces.
- .14 Tank refilling connections shall be of closed type and suitably grounded during bunkering operations.
- .15 Hazardous zone areas shall be designed in accordance with the rules of the RO.
- .16 Appropriate warning signs addressing the dangers of smoking, open flames, radio transmitting equipment, etc., shall be provided in areas including, but not limited to:
 - (a) bunkering;
 - (b) dispensing;
 - (c) tank storage; and
 - (d) vent outlets.

7.1.3 Spaces designed to contain vehicles

- .1 Enclosed spaces designed to contain vehicles, such as jet skis, automobiles, motorcycles, etc., with flammable liquids in their tanks shall be fitted as follows:
 - (a) with a fixed fire detection and fire alarm system complying with the requirements of SOLAS II-2 and the FSS Code, Chapter IX;
 - (b) a gas detection system shall be provided with audible and visible alarms on the bridge and where the crew can be easily alerted;
 - (c) a manually activated deluge water spray system of capacity to cover the total area of deck and container/vehicle support platform(s) (if any) at a rate of 3.5 L/m² per minute; or for a space in which the provision of a deluge system would be inappropriate and or impractical, alternative provisions shall be made to the satisfaction of the Administrator;

- (d) adequate provisions shall be provided for the drainage of water introduced to the space by §7.1.3.1c above. Drainage shall not lead to machinery or other spaces where a source of ignition may exist nor shall they drain directly overboard; and
 - (e) electrical equipment, including fixed and portable lighting, for use in the tank space and within the hazardous zone areas shall be kept to a minimum and shall be certified safe for flammable vapors. The electrical equipment and installation shall be to the rules of the RO.
- .2 The location of flammable liquid storage, quantities of flammable liquid, and procedures to be followed in an emergency shall be approved and recorded on the fire safety plan and/or safety manual, as appropriate.
- .3 Areas below the weather deck shall be provided with continuous pressure-positive ventilation at each level on which vehicles are transported. Each ventilation system shall be totally independent and isolated from all other ventilated spaces.
- (a) Each ventilation outlet shall not be less than 10 m separated from any opening to an accommodation space, machinery ventilation intake, accommodation heating, ventilation and air conditioning (HVAC)/ventilation intake, or unprotected electrical source.
 - (b) The ventilation system shall be ducted and mechanically forced in order to continuously supply air to the space so that at least six air changes per hour occur based on the volume of the empty space. Any reduction of the airflow shall be signalled by both audible and visual alarms on the navigating bridge and at the “in port” control station(s).
 - (c) The ventilation system shall be capable of rapid shut down and automatic closure in the event of fire
 - (d) The exhaust intake shall be located at the lowest point possible in the space.
 - (e) Any fans located in the space or ducting for the space shall be certified safe for the flammable liquid and its vapor.

7.2 Fire Control Plans

- .1 A fire control plan shall be permanently and clearly exhibited in an easily visible and prominent place for the guidance of the Master and crew of the yacht. The plan may be a combined fire and safety plan and shall be subject to review during plan approval processes on classed yachts by the Classification Society or on unclassed yachts by the AR.

- .2 The content of the plan shall adequately show the positions of stowage of the life-saving and fire-fighting appliances. Symbols used on the plan shall comply with the recognized international standard in accordance with *Fire Control Plans, Escape Route Signs, and Life-Saving Symbols* ([MN 2-011-10](#)); however, the symbols used in the fire control plan shall remain consistent to those used to identify the actual location of various equipment.
- .3 For each deck, the plan shall, at a minimum, show:
 - (a) the position of control stations;
 - (b) sections of the yacht which are enclosed respectively by “A” class divisions and “B” class divisions;
 - (c) location of flammable liquid storage (see [§7.1](#) above);
 - (d) particulars and locations of fire alarms, fire detection systems, suppression systems, and fixed and portable fire extinguishing appliances;
 - (e) fireman’s outfit(s);
 - (f) means of access and emergency escapes for compartments and decks; and
 - (g) locations and means of control of systems and openings which should be closed down in a fire emergency.
- .4 The plan required by §7.2.1 shall be regularly updated. Updated alterations shall be applied to all copies of the plan without delay. Each copy of the plan shall include a list of alterations and the date on which each alteration was applied.
- .5 A duplicate current plan shall be permanently stored in a prominently marked weather-tight enclosure readily accessible to assist non-yacht fire-fighting personnel who may board the yacht in a fire emergency.
- .6 Instructions relevant to the maintenance and operation of all the equipment and installations on board for the fighting and containment of fire shall be kept in one document holder, readily available in an accessible location.
- .7 All yachts shall be provided with a yacht-specific training manual, as required. Refer to [§20.3](#) below.

7.3 Ventilation

- .1 The ventilation systems provided in way of machinery spaces and galleys are to be designed to sufficiently prevent the accumulation of flammable gasses and be capable of being shut down from outside of the space.
 - (a) All inlets and outlets of the ventilation system shall be capable of being closed from outside the space.

(b) The locations to operate the shut-off and closure as required shall be such that they are easily accessible in case of an emergency.

- .2 Ventilation ducts that feed or exhaust air from high risk areas such as machinery spaces, garages containing vehicles with fuel in their tanks, fuel storage lockers, etc., shall not pass through an accommodation space.

If this requirement is unachievable, the ducts shall be constructed of steel or other equivalent material and insulated to the same fire integrity as the space it serves. In addition, automatic fire dampers shall be fitted to the ducts where they pass through the high risk area into the accommodation space; they shall also be capable of being closed manually.

- .3 Ventilation ducts that feed or exhaust air from accommodation, service, and control spaces shall not pass through high risk areas such as machinery spaces, garages containing vehicles with fuel in their tanks, fuel storage lockers, etc.

If this requirement is unachievable, the ducts shall be constructed of steel or other equivalent material and insulated to the same fire integrity as the high risk area through which it passes. In addition, automatic fire dampers shall be fitted to the ducts, where they pass through the accommodation space into the high risk area, on the accommodation side of the ducts that pass through the high risk area. The automatic fire dampers shall also be capable of being closed manually.

- .4 Storage rooms that contain highly flammable products shall be provided with ventilation that is separate and independent of other ventilation systems. The inlets and outlets of the systems shall be positioned as to pose the lowest risk possible and shall be fitted with flame arrestors.

- .5 Ventilation serving Category A machinery spaces shall be separate and independent of systems serving other spaces.

- .6 Ventilation serving enclosed spaces containing free standing fuel tanks shall be separate and independent of systems serving other spaces.

- .7 Ventilation shall be provided for areas where batteries are stored in order to prevent dangerous accumulations of flammable gas.

- .8 The ducts of exhaust ventilation for clothing driers shall be provided with access at suitable locations for cleaning and inspection.

- .9 Exhaust ducts from galley ranges shall be fitted with suitable means for extinguishing and containing the fire within the duct. Exhaust ducts that pass through accommodation spaces shall be fitted with additional fire dampers at the accommodation boundaries. This system shall be to the satisfaction of the RO.

7.4 **Means of Escape**

- .1 In order to aid with the escape of persons on board in the case of an emergency, means shall be provided to ensure quick and safe access to the life raft embarkation deck.
- .2 The arrangement of the hull shall be such that all under deck compartments are provided with a satisfactory means of escape. In the case of the under deck and above deck accommodations and engine room spaces, two means of escape from every restricted space or group of spaces shall be provided.

Only in an exceptional case will one means of escape be accepted by the Administrator, and then only if the means of escape provided does not require passage through a hazardous area, e.g., a galley or engine room; leads directly to the open air; and it can be demonstrated that the provision or retrofitting of a second means of escape would be impractical or detrimental to the overall safety of the yacht.

- .3 Secondary means of escape which pass through windows or hatches shall have a minimum clear opening not less than 600 mm by 600 mm and shall provide escape to an open deck:
 - (a) Where a second means of escape is via a sealed window, breakable glass, not polycarbonate or laminated glass, which can be readily broken with a conveniently located crash hammer, is acceptable.
 - (b) Where not practicable to comply with the sill requirements, weatherdeck flush hatches may be used as a secondary escape from the accommodation spaces.
 - (c) The Administrator may consider, on a case-by-case basis, a second means of escape from an accommodation space that leads via a hatch into another space.
- .4 All doors and hatches in escape routes shall be able to be opened from either side to allow for escape from and for entry into the space (e.g., by rescue workers). In the direction of escape, they shall be able to be opened without the use of a key. All handles on the inside of weather-tight doors and hatches shall be non-removable.
- .5 In the accommodation, where concealed escapes and routes may be used, they both are to be clearly marked.
- .6 All escapes and escape routes shall be kept clear of any other item or fitting that may impede escape during an emergency.

- .7 The design of the escapes and escape routes shall be in accordance with international conventions and codes.

7.5 Open Flame Gas Appliances and Recreational Fire Appliances

- .1 An open flame gas appliance provided for cooking, heating, or any other purpose shall comply with the requirements of ISO 10239:2014 or an equivalent standard.
- .2 Recreational Fire Appliances as defined in Chapter 1 shall meet the requirements of *Recreational Fire Appliances* ([MN 2-011-57](#)).

7.6 Paints, Varnishes, and Other Finishes

Paints, varnishes, and other finishes which pose an undue fire hazard, shall not be used in the engine room, galley, or in other areas of high fire risk. Elsewhere, such finishes should be kept to a minimum.

7.7 Fire Detection and Fire Alarm Systems

Fire detection and fire alarm systems shall be installed to the satisfaction of the RO. They must be appropriate to the hazard identified and space concerned.

- .1 On yachts of more than 24 m in length, a fire detection and fire alarm system shall be installed in accordance with SOLAS II-2/7 and the FSS Code. The system shall be provided with a control panel located within the wheelhouse and audible alarms provided in locations where they are most likely to be heard. The system shall be comprised of smoke, heat, or other suitable detectors fitted in the machinery space and galley as a minimum. In-yachts of 30 m in length and over, suitable detectors shall be fitted in all enclosed spaces, except those that afford no substantial fire risk (such as toilets, bathrooms, void spaces, etc). Manually operated call points shall be placed to ensure a readily accessible means of notification.
- .2 On yachts of 24 m or less in length, the fire detection and fire alarm systems requirements above are not mandatory. However, the fire detection and fire alarm system installed shall meet the following minimum requirements:
 - (a) All fire detectors shall provide an audible warning that can be heard in the space concerned and in the control position (e.g., wheelhouse) when the vessel is in operation.
 - (b) Where the yacht's total installed power (propulsion and electrical generation) is greater than 750 kW, the fire detectors must be fitted in all engine spaces. The alarm must be able to be heard throughout the yacht.

- (c) On yachts where an area (e.g., engine space, galley, sleeping accommodation) is identified by the RO as posing a fire risk to either passengers or crew, fire detection equipment shall be installed to protect that area.
 - (d) Additional and/or different types of fire detectors may be required to comply with §7.7.3 below.
- .3 In the exceptional case where a space or compartment has only one means of escape, the integrity of the escape route shall be protected by installing fire detectors that give instantaneous, early warning of danger by means of audible and visible alarms. The alarms shall be audible throughout the yacht.

8.0 MACHINERY FOR PYLCs OF 300 GT AND ABOVE

8.1 General Requirements

- .1 Where a yacht operates with periodically unattended machinery spaces, the machinery shall meet the requirements of SOLAS II-1/E to the extent that is reasonable and practicable.
- .2 Plastic piping may be accepted where the piping and the arrangements for its use meet the requirements of the 2010 FTP Code.
- .3 The requirements for main propulsion are based upon the installation of diesel powered units, burning distillate fuels which are not required to be heated. When other types of main propulsion systems are proposed, the arrangements and installation may be considered by the Administrator.
- .4 Where gas turbines are to be fitted, reference should be made to Chapter 9.3 of the International Code of Safety for High-Speed Craft (HSC 2000 Code), which shall be used as guidance for installation requirements. The installation shall be to the satisfaction of the RO.

8.2 Installation

- .1 Notwithstanding the requirements referred to in §8.1 above, the machinery, fuel tanks, and associated piping systems and fittings shall be of a design and construction adequate for the service for which they are intended.
- .2 The machinery, fuel tanks, and associated piping systems and fittings shall be installed and protected so as to reduce to a minimum any danger to persons during normal movement about the yacht; due regard shall be made to moving parts, hot surfaces, and other hazards.

- .3 Means shall be provided to isolate any source of fuel that may feed a fire in an engine space. Fuel shut-off valves shall be capable of being closed from a position outside the engine space. The valve(s) shall be fitted as close as possible to the fuel tank(s).
- .4 When a glass fuel level gauge is fitted, it shall be of the “flat glass” type with self-closing valves between the gauge and the tank.
- .5 Notwithstanding the requirements of §8.1 above, in a fuel supply system to an engine unit, when a flexible section of piping is installed connections shall be of a screw type or equivalent Approved Type. Flexible pipes shall be fire resistant or metal reinforced or otherwise protected from fire.
- .6 All fuel lines are to be properly supported by suitable brackets to the satisfaction of the Administrator or its representative. Materials and fittings shall be of a suitable recognized national or international standard that provides for a fire rating of at least 800°C for 30 minutes.
- .7 Steel filter bowls are required; glass or plastic filter bowls are not acceptable.
- .8 External high-pressure fuel delivery pipes between the high pressure fuel pumps and fuel nozzles are to be protected with approved jacketed tubing capable of containing fuel spills in case of a fuel line failure. Means for the collection of fuel, including alarm arrangements, shall be provided in the event of a fuel line failure.
- .9 Fuel oil lines shall not be located immediately above or near units of high temperature including exhaust manifolds, silencers, or other equipment required to be insulated. Fuel oil lines shall be arranged far apart from hot surfaces, electrical installations, or other sources of ignition.
- .10 Fuel oil line joints shall be protected (anti-splash tape or equivalent) to avoid spraying or leaking onto a source of ignition.
- .11 Multi-engine installations which are supplied from one common fuel source shall be provided with means of isolating the fuel supply to the individual engines. The means of isolation shall not affect the operation of the other engine(s) and shall be operable from a position which would not be rendered inaccessible by a fire or spill on any of the engines.
- .12 Machinery exhaust systems shall not normally pass through any accommodation spaces unless they are fitted in a gas tight trunk or each space is fitted with a carbon monoxide detector where the alarm is to be provided locally and at a continuously manned station.

8.3 Steering Gear

8.3.1 Steering Systems

- .1 The steering gear shall be capable of turning 35° from one side to 35° on the other side at the maximum ahead service speed of the yacht and, under the same conditions, 35° from one side to 30° on the other side in not more than 28 seconds.
- .2 Where the main steering gear comprises two or more identical power units, the conditions of §7.3.1.1 shall apply for each single unit.
- .3 When appropriate to the safe steering of the yacht, the steering gear shall be power operated.

8.3.2 Emergency Steering

In the event of failure to the main steering system, means for emergency steering shall be provided.

8.4 Bilge Pumping Arrangements

8.4.1 Pumps

- .1 All yachts shall be equipped with at least two fixed and independently powered pumps with suction pipes so arranged that any compartment can be effectively drained when the yacht is heeled to an angle of up to 10° under all practical circumstances.
- .2 The location of pumps and their individual power supplies and controls, including those for bilge valves, shall be such that in the event of any one compartment being flooded another pump is available to control progressive flooding to other compartments.
- .3 Each bilge pump suction line, other than the emergency suction line, shall be fitted with an efficient strum box or strainer.
- .4 Portable semi-submersible bilge pumps, preferably diesel driven, may be considered by the Administrator or its representative as an alternative to one of the two required pumps.

8.4.2 Periodically Unmanned Machinery Spaces

In the case of a yacht where the propulsion machinery space may be unmanned at any time, a bilge level alarm shall be fitted. The alarm shall be able to provide an audible and visual warning in the crew mess and in the wheelhouse. The location of the audible

and visual alarm may be approved by the Administrator elsewhere on the yacht if it is considered that such a location may be more practical.

8.4.3 Pumping and Piping Arrangements

- .1 Pumping and piping arrangements for bilges into which fuel or other oils of similar or higher fire risk could collect, under either normal or fault conditions, shall be kept clear of accommodation spaces and separate from accommodation bilge systems. Bilge level alarms which meet the requirements of §8.4.2 above shall be fitted to all such bilges in spaces that are unmanned at any time.
- .2 Approved plastic bilge piping may be accepted outside the engine room. The materials used for bilge piping in the engine room shall meet the fire resistant requirements of a Classification Society.
- .3 All distribution boxes and manually operated valves in connection with the bilge pumping arrangements shall be in positions which are accessible under ordinary circumstances.
- .4 It shall be ensured that satisfactory emergency bilge pumping (independent of the main bilge pumps) is provided.
- .5 The bilge system shall be designed to ensure that there is no direct uncontrolled discharge of bilge water into the marine environment. Emergency bilge discharge valves and other overboard discharge valves of a similar nature that are normally closed shall be sealed in the closed position with numbered seals. The mini-ISM shall implement a suitable method, either manual or electronic, for recording the changes in the process, including removal and replacement of numbered seal tags, testing of valves, maintenance, and other operational requirements. In accordance with IMO Circular [MSC-MEPC.1/Circ.3](#), *Blanking of Bilge Discharge Piping Systems in Port*, the sealing of valves of an emergency nature shall not be construed as a requirement for the valve to be blanked or physically locked. It shall be ensured that such valves remain available for use at all times in case of an emergency situation, and valve sealing may be accomplished through use of a breakable seal, electronic tracking, or similar method.
- .6 Yachts of less than 400 GT shall be equipped, as far as practicable, to retain oil or oily mixtures on board and/or discharge them in accordance with the requirements of MARPOL Annex I.
- .7 Yachts of 400 GT and above shall full comply with the regulations of MARPOL Annex I, except as specified otherwise in Annex I. For further guidance, refer to *MARPOL Standard Discharge Connectors on Yachts* ([TC 5](#)).
- .8 Special consideration shall be given to *Oil Filtering Equipment and Control of Operational Discharge of Oil* ([MN 2-013-3](#)).

8.5 Electrical Installations

8.5.1 Installation

- .1 Overload and short circuit protection of all circuits shall be provided, except engine starting circuits supplied from batteries.
- .2 Lighting circuits, including emergency circuits, shall be distributed through all spaces and in such a manner that a total blackout cannot occur due to the tripping of a single protective device.
- .3 Electrical devices working in potentially hazardous areas, into which petroleum vapor or other hydrocarbon gas may leak, shall be provided with protection against the risk of igniting the gas. Reference should be made to §[7.1](#) above.
- .4 Exposed metal, such as casings, of electrical machines and equipment, which are not intended under normal conditions to conduct electricity but which are liable under fault conditions to do so, shall be earthed unless the machines or equipment are:
 - (a) supplied at a voltage not exceeding 50 V direct current or 50 V root mean square between conductors (auto-transformers shall not be used for the purpose of achieving this voltage); or
 - (b) supplied at a voltage not exceeding 250 V by safety isolating transformers supplying only one consuming device; or
 - (c) constructed in accordance with the principle of double insulation.
- .5 When a distribution system with no connection to earth is used for power, heating, or lighting, whether it is main or emergency, a device capable of indicating an abnormally low insulation value shall be provided.
- .6 Where a risk of lightning strike is identified reference shall be made to ISO 10134:2003, and the proper protection provided.
- .7 Electric cables and wiring external to equipment shall be at least of a flame-retardant type and shall be so installed as not to impair their original flame-retarding properties. The Administrator may permit the use of special types of cables such as radio frequency cables, which do not comply with this requirement. Further:
 - (a) electric cables and wiring serving essential or emergency power, lighting, internal communications, or signals shall so far as is practicable be routed

clear of galleys, laundries, machinery spaces of Category A and their casings, and other high fire risk areas.

- (b) electric cables connecting fire pumps to the emergency switchboard shall be of a fire-resistant type where they pass through high fire risk areas. Where practicable, all such cables shall be run in such a manner as to preclude their being rendered unserviceable by heating of the bulkheads that may be caused by a fire in an adjacent space.
- .8 Electric cables and wiring shall be installed and supported in such a manner as to avoid chafing and other damage.

8.5.2 Emergency Sources of Power

- .1 An emergency source of electrical power shall be provided on board the yacht.
- .2 The electrical power, associated transforming equipment (if any), means to transfer power, and the emergency switchboard shall be located above the uppermost continuous deck and shall be readily accessible from the open deck.
- (a) The Administrator may consider alternative arrangements for the location of the emergency source of power as long as the location is protected from fire and flooding; however, it shall never be forward of the collision bulkhead. The electrical emergency switchboards shall in all cases be located above the uppermost continuous deck.
 - (b) When an emergency generator is provided, the alternative location must be readily accessible from an open deck and separated from main engines and main switchboards to ensure continued operation. The emergency generator shall be self-contained.
- .3 Emergency electrical power shall be sufficient to provide power for three hours duration at maximum output, which includes powering all of the following:
- (a) power supply to navigation lights;
 - (b) VHF radio;
 - (c) ship earth radio station;
 - (d) MF or MF/HF radio (if installed);
 - (e) internal communication equipment required in an emergency;
 - (f) fire detection alarm system and fire door holding and release system;

- (g) intermittent operation signaling lamp, ships whistle, and manually operated call points;
 - (h) all internal signals required in an emergency;
 - (i) one fire pump; and
 - (j) one bilge pump.
- .4 Emergency electrical power shall be sufficient for a period of 30 minutes if any of the following are installed:
- (a) watertight doors; or
 - (b) emergency arrangements to bring the elevator to deck level for escape.

8.5.3 Emergency Lighting

An emergency source of lighting shall be provided which shall be independent of the general lighting system and sufficient to enable persons to make their way from the accommodations or working spaces up to the open deck and evacuate the yacht, if necessary. This lighting, supplemented by flashlights, shall also be sufficient to permit emergency repairs.

8.5.4 Batteries

- .1 Batteries shall be of a type suitable for marine use and not susceptible to leakage.
- .2 Batteries shall be suitably stored, secured, and sea fastened.
- .3 In areas where batteries are stored, adequate ventilation shall be provided to prevent an accumulation of gas that may be emitted.
- .4 In areas where unsealed batteries are stored, personal protective equipment shall consist, at a minimum, of protective gloves, fully closed goggles or face mask, eye wash, and an apron.
- .5 Particular caution, with respect to fire hazards, should be taken when using electronic portable devices powered by lithium-ion batteries.

8.5.5 Battery Systems for (hybrid) propulsion

Where batteries are used for propulsion or electric power supply during ship operations, the battery system design, operation, and spaces containing these systems shall be designed, installed, and approved in accordance with the Rules of a Classification Society.

9.0 FIRE-FIGHTING EQUIPMENT FOR PYLCs

9.1 General Requirements

- .1 Fire-fighting appliances shall be of an Approved Type and shall be to the satisfaction of the Administrator or its authorized representative.
- .2 Any fire-fighting appliances provided in addition to those required by this section shall be of an Approved Type.
- .3 The location, installation, testing, and maintenance of all equipment shall be to the satisfaction of the Administrator and in accordance with *Maintenance and Inspection of Fire Protection Systems and Appliances* ([MN 2-011-14](#)).
- .4 The location of concealed fire-fighting appliances shall be clearly marked; however, the marking need not comply with IMO signs, but must be suitably positioned and visible to identify the location of the fire-fighting equipment.

9.2 Specific Requirements

9.2.1 Fire Pumps

- .1 At least two fire pumps shall be provided on board a yacht; of which one must be an independent power-driven pump.
- .2 The power-driven fire pump shall have a capacity of:

$$2.5 \times (1 + 0.066 \times (L(B+D))^{0.5})^2 \text{ m}^3/\text{hour}$$

Where:

L is the Load Line Length;

B is the greatest moulded breadth; and

D is the moulded depth measured to the bulkhead deck at amidships.

- .3 The pump shall, when discharging at full capacity through any two fire hydrants, be capable of maintaining a pressure of 0.2N/mm² at each hydrant so long as the fire hose can be effectively controlled at this pressure.
- .4 The second fire pump, if not meeting the requirements of §9.2.1.2 above, shall have the capacity of at least 80% of that required in §9.2.1.2 above and may be:
 - (a) a portable fire pump with a permanent sea connection external to the machinery space and having the ability to feed the fire main; or
 - (b) a bilge pump that can be, by means of valves, connected to the fire main.

- .5 Each centrifugal pump shall be provided with a non-return check valve in the connection to the fire main.

9.2.2 Fire Main and Hydrants

- .1 A fire main with connected fire hydrants shall be fitted to the yacht.
- .2 The fire main and hydrants shall be so arranged that, if necessary, one length of hose can be used to provide one stream of water to any location on board that is normally accessible to the passengers or crew including any store room or storage compartment.

The fire main and hydrants shall be arranged to avoid being readily damaged.

- .3 The fire main and all connections to the hydrants shall have an inner diameter and schedule that is appropriately sized for the maximum discharge rating of the pump(s) connected as specified by the manufacturer.
- .4 The fire main and hydrants shall be made of materials that:
 - (a) are not readily rendered ineffective by heat unless adequately protected; and
 - (b) do not readily corrode.
- .5 The fire main and hydrants shall be so arranged to avoid the possibility of freezing.
- .6 Where the second fire pump is fitted in a different location than the primary pump (e.g., outside of the machinery space), isolating valves that separate the section of the fire main within the machinery space containing the primary fire pump(s) from the rest of the fire main shall be fitted so that the secondary pump may feed the fire main separately from any piping positioned within the machinery space.
 - (a) The isolating valves shall be of a manually operated type fitted in an easily accessible location outside of the machinery space.
 - (b) If any part of the isolated section of the fire main must pass through the machinery space it shall be insulated to “A-60.”
- .7 An isolating valve shall be fitted to each hydrant so that any hose may be removed while the fire pumps are in operation without losing pressure.
- .8 At a minimum at least two separate hydrants shall be provided in locations where if one is rendered inaccessible the other is likely to remain free of debris, water, fire, or other hindrance.
- .9 The fire main shall have no connection(s) or permanent function(s) other than for fire-fighting or anchor wash down.

- .10 Where a classed yacht has a class notation indicating a periodically unattended machinery space or where only one person is required on watch, there shall be the ability to remotely start the fire pumps from the navigating bridge and the fire control station.

If the fire control station is positioned at a location less than two compartments removed or 10 m, whichever is less, from the navigating bridge, the remote start need only be provided at one of the locations.

9.2.3 Fire Hoses and Nozzles

- .1 Fire hoses shall be of an Approved Type and be provided with similarly approved nozzles and couplings.
- .2 Fire hoses, nozzles, and other associated tools and fittings shall be kept in readily accessible and marked locations close to the hydrants or connections on which they will be used.
- .3 In interior spaces, hydrants, nozzles, and any other associated connections necessary for fire-fighting shall be connected and readily accessible at all times.
- .4 Fire hoses shall not exceed 20 m in length and the diameter of a lined hose for use with a power-driven pump shall not be less than 38 mm.
- .5 Jet or spray nozzles shall have a diameter of 19 mm, 16 mm, or 12 mm depending on fire-fighting purposes and shall have the ability to be opened and closed.

For accommodation and service spaces, the diameter of nozzles need not exceed 12 mm.

- .6 Smaller diameter hoses and jet/spray nozzles will be considered as meeting the requirements of this Code as long as they will not negatively impact the fire-fighting ability of the system, as designed.
- .7 The number of fire hoses and nozzles provided shall correspond to the specific and unique requirements of the yacht, but in no case shall there be less than three fire hoses and nozzles on each yacht.

9.2.4 Portable Fire Extinguishers for Use in the Accommodation and Service Spaces

- .1 The number, location, capacity, and fire extinguishing medium type shall be selected in accordance with the specific and unique requirements of the yacht, but in no case shall there be less than three fire extinguishing mediums on each yacht.

The fire extinguishers provided shall be of an approved 5 kg/9 L type and capacity. They shall have, as far as is reasonable and practicable, a uniform method of operation.

For each deck there shall be at least one portable extinguisher available within a maximum distance of 10 m from any location. The extinguisher shall be within the same fire zone or watertight subdivision.

- .2 Carbon dioxide portable fire extinguishers shall not be located in or provided for use in accommodation spaces.
- .3 In locations containing electrical or electronic equipment, batteries, and/or appliances necessary for the safe operation of the yacht, fire extinguishers of a medium that is neither electrically conductive nor harmful to the equipment and/or appliances shall be installed. In locations where lithium-ion or other rechargeable batteries are stowed, the type of fire extinguishing medium shall specifically be considered for effectiveness.
- .4 Fire extinguishers shall be located external to but adjacent to the entrance of the space for which they are intended to be used. Additionally, they shall be in a marked and easily visible location which is easily accessible in an emergency and where damage cannot readily occur.
- .5 Spare charges shall be provided on board for 100% of the first four portable fire extinguishers and at least 50% of each type and capacity of the remaining portable fire extinguishers capable of being recharged on board.
- .6 When the extinguishers cannot be recharged onboard, additional spare extinguishers shall be provided in the same quantities as required by §9.2.4.5 above.

9.2.5 Fire Extinguishing in Machinery Spaces

- .1 Category A machinery spaces containing internal combustion type machinery shall be provided with:
 - (a) a fixed fire extinguishing system approved in accordance with the FSS Code; and
 - (b) one portable fire extinguisher for oil fires for each 75kW (100 horsepower), but no more than seven extinguishers are required; or
 - (c) two portable fire extinguishers for oil fires together with:
 - (i) one foam extinguisher of 45 L capacity; or
 - (ii) one carbon dioxide portable fire extinguisher of 16 kg capacity. In lieu of one such extinguisher, in small engine rooms, two 9 kg portable extinguishers may be accepted by the RO.

- .2 In a machinery space containing an oil fuel settling tank, oil fuel unit, oil fired boiler, or incinerator, a fixed fire extinguishing system complying with the standards as found in the FSS Code shall be provided.
- .3 In addition to that which is specified in §9.2.5.1 above, the number, location, capacity, and fire extinguishing medium type shall be selected in accordance with the specific and unique requirements of the yacht, but in no case less than two for any individual machinery space containing any part of an oil fuel installation.
- .4 Additionally one portable fire extinguisher shall be readily accessible for use in the steering gear compartment.

9.2.6 Additional Fire Appliances

- .1 One fire blanket shall be provided in the galley and in other areas where cooking may occur.
- .2 Two fireman's outfits including an approved self-contained breathing apparatus (SCBA) with spare air cylinders for each outfit shall be provided.
- .3 The fireman's outfits and SCBAs shall be in accordance with SOLAS Ch. II and the FSS Code.
- .4 For yachts of less than 24 m in length where it can be demonstrated to the satisfaction of the AR that compliance with §9.2.6.2 above is impractical and does not contribute to the safety of the vessel and/or the persons onboard, the yacht may be exempted from the carriage requirements of these appliances.
- .5 For yachts of 24 m or more in length but less than 300 GT, the Administrator may accept alternative arrangement for compliance with §9.2.6.2 above, taking the provisions of Chapter I, [§2.3.2](#) in consideration. Proposals for any alternative arrangements may be considered by the Administrator provided the yacht has in place mitigating measures to ensure safe escape from the interior in case of fire or smoke. Mitigating measures may consist of, but are not limited to:
 - (a) placing of sufficient additional Emergency Escape Breathing Devices (EEBDs) in all cabins for all inhabitants; or
 - (b) the provision of a fixed firefighting installation (meaning a sprinkler or water mist system); or
 - (c) a clear demonstration that there is clear and direct access to the outer decks from the cabins and other accommodation spaces.

10.0 LIFE-SAVING APPLIANCES

10.1 General Requirements

10.1.1 Life-Saving Appliances

- .1 All yachts shall be provided with life-saving appliances in accordance with the Life-Saving Appliances listed in Table 22 below:

Table 22
Life-Saving Appliances (see sections of this Chapter as noted below)

Size of PYLC Category	<500 GT		
	2	1	0
Life Rafts (see §10.2.1)	Yes		
Rescue Boat (see §10.2.3)	No	Yes	
Recovery of Persons from the Sea (see §10.2.2)	Yes		
Lifejackets (see §10.2.5)	Yes		
Immersion Suits (see §10.2.6)	Yes		
Life Buoys (Total) (see §10.2.4)	Four		Six
Life Buoys with Light and Smoke; or SOLAS-Approved Strobe (see §10.2.4.4)	Two		
Life Buoys with Buoyant Line (see §10.2.4.3)	Two		
Line Throwing Appliances with Spare Charge(s) see §10.2.8)	One		
Rocket Parachute Flares (see §10.2.7)	Four		Six
Red Hand Flares (see §10.2.7)	Six		Twelve
Smoke Signals (see §10.2.7)	Two		
Portable VHF	Two		Three
EPIRBs (see §10.2.9)	One		
SARTs (see §10.2.10)	One		Two
General Alarm (see §10.2.11)	Yes		
Posters / Signs / Placards Showing Survival Craft and Equipment Operating Instructions	Yes		
Training Manual (see §20.3)	Yes		
Mini-ISM (see Annex 1)	Yes		
Life-Saving Signals and Rescue Poster (see §10.2.13)	Yes		

- .2 All PYLCs shall be provided with an approved life-saving appliances general arrangement plan (normally combined with the fire control general arrangement plan). Symbols used on the plan(s) shall comply with *Fire Control Plans, Escape Route Signs, and Life-Saving Symbols* ([MN 2-011-10](#)).

- .3 All equipment fitted shall be of an Approved Type that is in accordance with *Life-Saving Appliances and Systems* ([MN 2-011-37](#)). Unless expressly provided otherwise, all life-saving appliances shall comply with the LSA Code and IMO Resolution [MSC.81\(70\)](#), *Revised Recommendation on Testing of Life-Saving Appliances*, as amended¹⁵.
- .4 Servicing of all life-saving appliances and associated equipment shall be at intervals as specified in MN 2-011-37. Approved disposable hydrostatic release units which have been approved for a service life of more than one year need not be serviced annually but shall be replaced at the end of their service life in accordance with the manufacturer's recommendations.
- .5 All life-saving equipment that may be provided, either mandatorily or voluntarily, must meet the requirements of this [§10.1](#).

When safety equipment is provided for use in supplementary activities, such as water sports, or used for training purposes, arrangements for its stowage and its marking shall ensure that it will not be mistakenly used as approved life-saving equipment in an emergency situation.

- .6 All life-saving equipment carried on board shall be fitted with retro-reflective material in accordance with the recommendations found in IMO Resolution [A.658\(16\)](#), *Use and Fitting of Retro-Reflective Materials of Life-Saving Appliances*. Retro-reflective material already fitted on existing life-saving appliances in accordance with IMO Resolution [A.274\(8\)](#), *Recommendation on Retro-Reflective Tapes on Life-Saving Appliances*, will continue to be accepted until it has to be replaced as a result of deterioration or damage.
- .7 The stowage and installation of all life-saving appliances is to be to the satisfaction of the Administrator or its representative, as applicable.
- .8 All life-saving appliances shall be kept in good condition and be ready for immediate use before any voyage is commenced and at all times during the voyage.
- .9 In the case of an emergency that necessitates the safe evacuation of the yacht, special consideration shall be given, and provisions made as necessary, to avoid interference from dangerous elements, above or below the waterline, such as propellers, impellers, stabilizers, sea chests, bow thrusters, etc.
- .10 Means shall be provided to prevent overboard discharge of water into survival craft during abandonment.
- .11 Maintenance of life-saving equipment shall be carried out in accordance with the instructions for onboard maintenance. See [§10.2](#) below.

¹⁵ Amended by IMO Resolutions [MSC.200\(80\)](#), [MSC.226\(82\)](#), [MSC.274\(85\)](#), [MSC.295\(87\)](#), [MSC.321\(89\)](#), [MSC.323\(89\)](#), [MSC.378\(93\)](#), [MSC.427\(98\)](#), and [MSC.472\(101\)](#).

10.1.2 Launching Appliances

- .1 Launching appliances shall be in accordance with the LSA Code Chapter VI, unless expressly provided otherwise in this Code.
- .2 Any inspection, servicing, or repair of cranes, wires, and associated parts of the launching appliances shall be carried out in accordance with *Life-Saving Appliances and Systems* ([MN 2-011-37](#)) and services developed by the manufacturer.
- .3 Falls for launching devices must comply to the requirements of the LSA code. When fibre rope falls are fitted, these shall meet the requirements of *Use and Maintenance of Non-Steel Wires/Falls on Yachts for Lifeboat/Rescue Boat/Life Raft Davits* ([MN 2-011-50](#)). Falls of other materials (e.g., stainless steel) may be considered by the Administrator on a case-by-case basis.

10.2 Equipment Carriage Requirements

10.2.1 Life Rafts

- .1 Life raft embarkation arrangements shall comply with the following:
 - (a) A means of embarkation of life rafts must be provided where the distance between the embarkation deck and the top of the life raft buoyancy tube exceeds 1 m when the yacht is in its lightest condition.
 - (b) Where the distance between the embarkation deck and the top of the life raft buoyancy tube exceeds 4.5 m when the yacht is in its lightest condition, davit launched life rafts shall be provided with at least one launching appliance also provided on each side of the yacht.
 - (c) A life raft will be considered as being readily transferable if it is able to be carried by two persons and can be launched within 5 minutes, away from its stowed location.
 - (d) The readily transferability of life rafts shall be demonstrated to the satisfaction of the RO.
- .2 The life rafts carried are to be stowed in Glass Reinforced Plastic (GRP) containers and must contain the necessary SOLAS emergency pack, the contents of which are dependent upon the yacht's limiting Category:
 - (a) Yachts in Category 2 must have life rafts equipped with a SOLAS B Pack; and

- (b) Yachts in Category 1 or 0 must have life rafts equipped with a SOLAS A Pack.
- .3 The life rafts carried on board the yacht shall each be of equal capacity or as near equal as possible.
- .4 Life raft approvals include approval of their stowage, launching, and float-free arrangements.
- .5 A yacht shall be provided with life rafts of such number and capacity that, in the event of any one life raft being lost, damaged, or otherwise rendered unusable there remains sufficient capacity for all persons on board.
- .6 For a yacht of less than 85 m in Load Line length, one or more life rafts are to be provided on each side of the yacht of sufficient aggregate capacity to accommodate the total number of persons on board. Life rafts are to be readily transferable for launching on either side of the yacht.

If life rafts are not readily transferable, additional life rafts shall be fitted so that life rafts having a total capacity of 150% of the yacht's complement are provided on each side of the yacht.

- .7 Life rafts, other than davit launched life rafts, shall be capable of launching from their stowed location and upon release, fall clear of any obstructions, superstructures, or hull with the vessel in an upright condition. Consideration shall be given to mitigate the risk of life rafts being trapped into recessed side decks or other structural features when the commercial yacht is in a heeled condition.
- .8 In lieu of meeting the requirements of §10.2.1.6 above, yachts limited to Category 2 may carry a sufficient number of life rafts, so that in the event of any one life raft being lost or rendered unserviceable, sufficient aggregate capacity remains on either side of the yacht for all persons on board. This may be achieved by transferring life rafts from one side to the other.
- .9 For a sailing yacht, when it is impractical to stow the life rafts required by §[10.2.1.6](#) above at the yacht's side, alternative arrangements may be accepted to provide life rafts having a capacity of 150% of the yacht's complement stowed on the centerline, subject to their being readily transferable to either side of the yacht.

10.2.2 Recovery of Persons from the Sea

- .1 Means shall be provided for the recovery of a person from the sea to the yacht. If a person is unconscious or unable to assist in the rescue, means shall be provided to recover them. This may be satisfied by an inflatable boat or rescue boat

provided with a suitable davit should it not be possible for the yacht itself to be used to recover persons from the sea.

- .2 All PYLCs shall have yacht-specific plans and procedures for the recovery of persons from the water. The plans shall identify the equipment intended to be used for recovery purposes and measures to be taken to minimize the risk to shipboard personnel involved in recovery operations, in accordance with *Plans and Procedures to Recover Persons from the Water* ([MN 2-011-47](#)).
- .3 The means of recovery shall be demonstrated to the satisfaction of the Administrator or its representative, as requested.
- .4 If an over side boarding ladder or scrambling net is provided to assist in the recovery of an unconscious person from the water, the ladder or net shall extend from the weather deck to at least 600 mm below the lowest operational waterline.

10.2.3 Rescue Boats

- .1 Unless specified otherwise in this section, all rescue boats and associated equipment covered in this section shall comply with the LSA Code Chapter V/5.1.
- .2 The launching of a rescue boat shall always be designed to allow it to be launched from a sheer vertical side of the yacht, as far as is practical, and in an area free of impediments or hazards. The rescue boat need only be able to be launched from one side of the yacht.
- .3 If the rescue boat is stowed forward, the launching appliances shall be entirely located in a position aft of the vertical extension of the aft most portion of the collision bulkhead.
- .4 The requirements of §10.2.2 above shall also be followed.
- .5 Yachts of Category 0 or 1 shall comply with the requirements of Chapter II §[17.2.4.5](#) or the following:
 - (a) a boat that is suitable for rescue purposes is carried on board but which is of a non-SOLAS Approved Type. In this case, the boat shall have capacity for not less than four persons, one of which should be assumed to be lying down. The boat may be a rigid, rigid inflatable, or inflatable tender and may be in any color but must be capable of displaying a highly visible color. Tubes of non-SOLAS inflatable boats shall have a minimum of three buoyancy compartments built in; and
 - (b) the launching appliances shall be capable of launching the boat within five minutes. When a power-operated crane is used as a launching device, it shall be capable of operation by hand in the event of a power failure. A secondary

power source (e.g., emergency generator power, battery, or hydraulic pump) is acceptable in lieu of emergency hand operation of the rescue boat crane; and

- (c) launching appliances and associated equipment shall be constructed to withstand a static load test of not less than 2.2 times the maximum working load. Acceptable factors of safety for wires, sheaves, and hooks shall not be less than 6, and for the remainder of the launching appliances, not less than 4.5. In addition, the appliances and associated equipment shall also be tested dynamically to 1.1 times the working load.
- .6 For yachts of Category 2, if a rescue boat complying with §10.2.3.1 to §10.2.3.5 above is not carried on board, alternative arrangements may be considered to the satisfaction of the RO, including:
- (a) a rescue boat of a SOLAS Approved Type which is towed by the main yacht; or
 - (b) a rescue boat which is stowed in the lazarette or garage, provided that it can be launched in a reasonable time frame and there is the ability to efficiently use the yacht itself to recover an unconscious person from the water; or
 - (c) a boat that is suitable for rescue purposes carried on board but which is of a non-SOLAS Approved Type. In this case, the boat shall have a capacity for not less than four persons, one of which should be assumed to be lying down. The boat may be a rigid, rigid inflatable, or inflatable tender and be in any color but must be capable of displaying a highly visible color. Tubes of non-SOLAS inflatable boats shall have a minimum of three buoyancy compartments built in; or
 - (d) the yacht, if it can be demonstrated that by virtue of the yacht's maneuverability it can effectively act as the rescue boat itself. In this case, the marked area shall be fully visible from the bridge wings or other areas where the yacht may be operated. However, consideration shall be given to §9.2.2 above; and
 - (e) if launching appliances are provided, these shall meet the requirements of [Chapter II](#), §[17.2.4.5\(b\)](#) or §10.2.3.5 above.
- .7 The rescue boat does not need to be brought back onboard the yacht if the occupants can be recovered from the rescue boat while it is still in the water.

10.2.4 Life Buoys

- .1 Life buoys shall be provided on the port and starboard sides of the bridge. They shall be equipped with self-activating light and smoke signals and shall be capable

of quick release. Where this is impractical, they may be stowed at the side of the yacht and provided with conventional release arrangements.

- .2 Life buoys shall meet SOLAS requirements; however, they may be white in color.
- .3 A buoyant line is required to be attached to two of the life buoys and is to have a minimum length of 30 m. Reference should be made to Table 22 and [§10.1.1](#) above.
- .4 For Category 2 yachts, the Light and Smoke MOB signal may be replaced by a SOLAS approved marker strobe light.
- .5 Each life buoy shall be marked with the yacht's name and Port of Registry.

10.2.5 Lifejackets

- .1 One adult SOLAS approved lifejacket shall be provided for each person on board plus spare adult lifejackets sufficient for at least 10% of the total number of persons on board, or two, whichever is the greater. Each lifejacket shall be fitted with a light and whistle.
- .2 There shall be at least two SOLAS approved inflatable lifejackets included in the number of lifejackets for use of the crew of any rescue boat or inflatable boat carried on board described in [§10.2.5.1](#) above.
- .3 When children or infants are carried on the yacht, one child or infant SOLAS approved lifejacket shall be provided for each child or infant, as appropriate. In addition, spare life jackets shall be carried onboard for at least of 10% of the total number of infants and/or children onboard.
- .4 Sufficient means of securing lifejackets to persons weighing up to 140 kg and a chest girth of up to 1,750 mm shall be provided as necessary.

10.2.6 Immersion Suits

- .1 One approved and appropriate sized immersion suit complying with the requirements of [§10.1.1](#) above shall be provided for each person on board.
- .2 A yacht which operates between latitude of 30° North (N) and 30° South (S) need not be provided with immersions suits or exempted in accordance with [Chapter I, §2.3.2](#).
- .3 An appropriately sized immersion suit must be provided for every person assigned to crew the rescue boat or assigned to the marine evacuation system party according to SOLAS Regulation III/7.3. An immersion suit provided under this requirement may be used to comply with [§10.2.1.1](#) above.

- .4 If applicable, immersion suits shall be provided for persons weighing up to 140 kg or with chest girths of 1,750 mm and for children.
- .5 The periodic testing of immersion suits shall be conducted according to *Life-Saving Appliances and Systems* ([MN 2-011-37](#)).
- .6 A yacht which operates outside of the parallels of latitude 30°N and 30°S or in areas where the seawater temperature at the time of operation is known and considered to be high enough to forego the safety provision of immersion suits, shall apply to the Administrator for a dispensation or exemption from the requirements. Full details of the proposed location, period of operation, and established temperature data from recognized authorities shall be provided. Immersion suits shall always be provided for the rescue boat crew and for the crew on repositioning voyages.

10.2.7 Pyrotechnics

Flares, complying with the requirements of Chapter III of the LSA Code, shall be positioned in a readily accessible location and in the quantities stated in Table 22 in [§10.1.1](#) above.

10.2.8 Line Throwing Appliances

For yachts in Category 2, appliances capable of firing two shots of line are required, for all other categories four shots of line capability is required.

10.2.9 Emergency Position-Indicating Radio Beacon (EPIRB)

- .1 A 406 MHz EPIRB shall be provided and installed in a readily accessible location ready to be manually released, capable of being placed in a survival craft, or floating free if the PYLC sinks. See *Frequency, Identification Numbers, Testing and Disposition of Satellite EPIRBs* ([MN 4-033-5](#)).
- .2 All EPIRBs are to be registered with the Administrator and are to be tested and serviced annually by an approved service provider.

10.2.10 Search and Rescue Transponder (SART)

The SART is to be stowed in an easily accessible position so that it can be rapidly placed in any survival craft. Means are to be provided in order that it can be mounted in the survival craft at a height of at least 1 m above sea level.

10.2.11 General Alarm

The general alarm may consist of the PYLC's whistle or siren.

10.2.12 Lighting

- .1 Alleyways, internal and external stairways, and exits giving access to the muster and embarkation stations shall be adequately lighted.
- .2 Adequate lighting is to be provided in the vicinity of survival craft, launching appliance(s) (when provided), and the area overboard in way of the launching position(s). The lighting shall be supplied from the emergency source of power.

10.2.13 Life-Saving Signals and Rescue Poster

When display space in the wheelhouse is restricted, the two sides of a SOLAS No. 2 poster (as contained in life raft equipment packs) may be displayed in lieu of a SOLAS No. 1 poster. Symbols used shall conform to *Fire Control Plans, Escape Route Signs, and Life-Saving Symbols* ([MN 2-011-10](#)).

11.0 NAVIGATIONAL LIGHTS, SHAPES, AND SOUND SIGNALS

11.1 General

- .1 yachts shall comply with the requirements of COLREGS '72.
- .2 Navigation lights shall have a primary and secondary means of power. The secondary source of power shall comply with §8.5.2.3, as applicable.
- .3 The requirement for duplication of navigation lights may be satisfied by having a spare lamp that can be fitted within three minutes while underway.
- .4 All navigation lights, including LED lights, shall meet the standards of IMO Resolution [MSC.253\(83\)](#), *Adoption of the Performance Standards for Navigation Lights, Navigation Light Controllers and Associated Equipment*.

12.0 NAVIGATIONAL AND BRIDGE EQUIPMENT AND BRIDGE VISIBILITY

12.1 Requirements

All yachts shall be provided with the equipment listed in Table 23, as applicable:

Table 23
(see Sections of this Chapter as noted below)

Navigational Equipment	up to 149 GT	150 to 299 GT	300 to 499 GT
Standard Magnetic Compass (see § 12.2.1)	✓	✓	✓
Spare Magnetic Compass (see § 12.2.1b)		✓	✓
Global Navigation Satellite System (GNSS) (see § 12.2.2)	✓	✓	✓

Table 23
(see Sections of this Chapter as noted below)

Navigational Equipment	up to 149 GT	150 to 299 GT	300 to 499 GT
Automatic Identification System (AIS) (see § 12.2.3)			✓
Long-Range Identification and Tracking (LRIT) System (see § 12.2.4)			✓
9 GHz Radar (see § 12.2.5)			✓
Radar Reflector (see § 12.2.12)	✓		
Pelorus or Compass Bearing Device (see § 12.2.1c)	✓	✓	✓
Echo Sounder (see § 12.2.8)			✓
Speed and Distance Measuring Device (see § 12.2.7)			
Barometer (see § 12.2.11)	✓	✓	✓
Anemometer and Inclinator (Sailing Yachts Only) (see § 12.2.11)	✓	✓	✓
Signaling Lamp / Handheld Searchlight (see § 12.2.9)	✓	✓	✓
Searchlight (see § 12.2.9 and § 12.2.10)	✓	✓	✓

Please refer to SOLAS V/19 for additional details.

12.2 **Navigational Equipment Requirements**

12.2.1 **Standard Magnetic Compass**

- .1 Every yacht shall be fitted with an efficient and approved magnetic compass complying with the following requirements, as appropriate:
 - (a) on a steel yacht it shall be possible to correct the compass for coefficients B, C, and D;
 - (b) the magnetic compass or a repeater shall be so positioned as to be clearly readable by the helmsman at the main steering position. It shall also be provided with an electric light, the electric power supply is to be a twin wire type;
 - (c) means shall be provided for taking bearings as near as practical over an arc of the horizon of 360°. This requirement may be met by the fitting of a Pelorus or, on a yacht other than a steel yacht, a handheld compass; and
 - (d) the compass shall be calibrated and a deviation log kept in accordance with *Magnetic Compasses Adjustment* ([MN 2-011-32](#)).

- .2 A spare magnetic compass interchangeable with the standard magnetic compass shall be provided on all yachts of 150 GT and above.
- .3 For yacht less than 300 GT the requirements of this §12.2.1 may be met by using a fluxgate compass, provided that a suitable back up power supply is available to power the compass in the event of failure of the main electrical supply. Where such a compass incorporates a capability to measure magnetic deviation by undertaking a calibration routine, and where the deviation figures are recorded within the device, a deviation card is not required.
- .4 If the yacht is intended to operate in polar regions (north of 70°N or south of 70°S), the effects on the magnetic compass shall be taken into consideration.

12.2.2 Global Navigation Satellite System (GNSS)

Every yacht shall carry a GNSS which is accurately integrated with other equipment.

12.2.3 Automatic Identification System (AIS)

.1 AIS Class-A

All yachts of 300 GT and over shall be fitted with an approved AIS in accordance with SOLAS regulation V/19.2.4. Please refer to *Automatic Identification Systems (AIS)* ([MN 2-011-17](#)).

.2 AIS Class-B

- (a) Yachts of less than 300 GT may be fitted with a Class-B AIS.
- (b) Daughter Craft, such as a tender or other watercraft, associated with a yacht may be fitted with a dedicated Class-B AIS. Where fitted, a permanent MMSI number must be assigned to each Daughter Craft by the Administrator.
 - (i) The Daughter Craft MMSI number will be listed on the yacht's radio station license as a permanent identification of the Daughter Craft. It must be programmed in the Daughter Craft AIS.
 - (ii) If other radio equipment (e.g., VHF, DSC) is fitted onboard the Daughter Craft, the MMSI number must be programmed in this equipment.
 - (iii) The Administrator must be notified if the commercial yacht ceases to tow or carry the Daughter Craft.

12.2.4 Long-Range Identification and Tracking (LRIT) System

Yachts of 300 GT and over of category 0 and 1 shall comply with the requirements of LRIT in accordance with SOLAS V/19-1. Refer to *Long-Range Identification and Tracking of Ships* ([MN 2-011-25](#)).

Yachts limited to Category 2 need not be fitted with an LRIT.

12.2.5 9 GHz Radar (X-Band)

All yachts of 300 GT and above shall carry an approved 9 GHz radar.

12.2.6 Nautical Charts and Nautical Publications or Electronic Chart Display and Information System (ECDIS)

Yachts shall carry nautical charts and nautical publications to plan and display the yacht's route for the intended voyage and to plot and monitor positions throughout the voyage. An approved ECDIS may also be accepted as meeting the chart carriage requirements provided that the provisions of *Nautical Chart and Publication Carriage and Electronic Chart Display and Information System (ECDIS) Requirements* ([MN 7-041-6](#)) are in place.

12.2.7 Speed and Distance Measuring Device

All yachts of 300 GT and above shall carry a speed and distance measuring device, or other means, to indicate speed and distance through the water.

12.2.8 Echo Sounder

All yachts of 300 GT and above shall carry an echo sounding device to measure and display the available depth of water.

12.2.9 Signaling Lamp

Yachts shall carry an approved signaling lamp and/or handheld searchlight that is not solely dependent on the yacht's main source of electrical power.

12.2.10 Searchlight

Yachts shall carry an efficient fixed or portable searchlight suitable for MOB search and rescue operations. This may be the approved signaling lamp required by §12.2.9 above.

12.2.11 Instruments

Yachts shall carry a barometer, in addition, sailing yachts shall carry an anemometer and an inclinometer.

12.2.12 Radar Reflector

On yachts less than 150 GT, a radar reflector, or other means, to enable detection by ships navigating by radar at both 9 and 3 GHz shall be carried.

12.3 Bridge Navigational Watch Alarm System (BNWAS)

Yachts of 150 GT and above and assigned Category 0 or 1 shall be fitted with a BNWAS. Refer to *Bridge Navigation Watch Alarm Systems* ([MN 2-011-40](#)) for full details.

12.4 Bridge Visibility

- .1 Yachts of 55 m or more in LOA shall comply with SOLAS V/22. Alternative arrangements may be considered by the Administrator or its representative.
- .2 Yachts of less than 55 m in LOA should comply as far as is reasonable and practicable to do so.
- .3 Windows to the conning position(s) shall not be of either polarized or tinted glass (also see §4.6.5 above). Portable tinted screens may be provided for selected windows.
- .4 Windows which are not inclined from the vertical plane top out in accordance with SOLAS V/22, shall have appropriate measures to avoid adverse reflections from within to the satisfaction of the RO.
- .5 Where the yacht's side is not fully visible from the bridge wing, wing station, or maneuvering station, alternative means for ensuring visibility (e.g., cameras) may be considered on a case-by-case basis, giving consideration to image quality, night vision, display screen size, and location.

13.0 RADIO

13.1 General

All yachts, regardless of GT, shall carry radio transmitting and receiving equipment appropriate for the Sea Areas in which the yacht operates. Sea Areas are as defined in SOLAS IV/2.1.12, 2.1.13, 2.1.14, and 2.1.15.

- .1 All yachts shall be equipped, at a minimum, as provided in Table 24 below.
- .2 Yachts of 300 GT and above, must ensure the operability of radio installations at all times. This can be done by duplication of equipment, shore-based maintenance, or at-sea electronic maintenance capability.

- .3 For yachts less than 300 GT, alternative arrangements for the radio installations shall be considered by the Administrator on a case-by-case basis.
- .4 Yachts certified for navigation in Sea Area A4 must have at least two of the methods referenced in §13.1.2 above.
- .5 All yachts shall be able to transmit a maritime distress alert by at least two separate and independent means. One of the individual means of transmitting a maritime distress alert may be satisfied by a satellite EPIRB, if is used as the secondary means of distress alerting. See §10.0, Table 22 for requirements on the carriage of two-way radiotelephone sets, EPIRBs, and SARTs.

Table 24

A1 ⁵	A1 + A2 ⁴	A1 + A2 + A3		A1 + A2 + A3 + A4
		Either	Or	
Navtex ¹	Navtex ¹	Navtex ¹	Navtex ¹	Navtex ¹
VHF DSC/RT	VHF DSC/RT* VHF RT*	2 VHF DSC/RT*	2 VHF DSC/RT*	2 VHF DSC/RT*
---	MF(DSC) Radio Telephone Or App. GMDSS Satellite ship earth station ³	MF(DSC) Radio Telephone Or App. GMDSS ship earth station ³	MF/HF(DSC) ² Radio Telephone	MF/HF(DSC) ² Radio Telephone
---	---	---	---	App. GMDSS ship earth station

* As the yacht is equipped with two VHF DSC/RT units, duplication of equipment (the VHF DSC/RT installations), as required by §13.1.3 and §13.1.4, is not required.

Table Notes:

1. If the yacht is navigating in an area where an international NAVTEX service is not provided, then the NAVTEX receiver shall be supplemented by an additional means of receiving Maritime Safety Information (MSI) transmissions such as the GMDSS Safety Net EGC.
2. Incorporating Narrow Band Direct Printing (NBDP) telegraphy or an alternative means of receiving MSI transmissions in the Sea Areas in which the yacht is operating.
3. For yachts navigating in Sea Area A2, in lieu of a MF(DSC) radio installation, an approved GMDSS Satellite service provider may be installed. For navigation in areas where no Sea Area A2 is declared, the yacht is required to be equipped with an approved GMDSS ship earth station.

4. Yachts of Category 0 or 1 which frequently navigate outside of Sea Area A2, the Administrator recommends full compliance with SOLAS IV.
5. If equipment is provided only for Sea Area A1, then this shall be noted as an additional operational limitation on the yacht compliance certificate.

13.2 Sources of Energy

All yachts regardless of GT shall comply with SOLAS IV/13, as amended by this section.

Yachts of less than 300 GT not meeting the requirements of SOLAS II-1/43 shall have sufficient reserve power supply to operate the radio equipment for a minimum of three hours.

13.3 Watches

While at sea, a yacht regardless of GT shall maintain a continuous watch in accordance with SOLAS IV.

13.4 Radio Personnel

A yacht shall carry at least one person qualified for distress and safety radio communication purposes. This person shall hold a Certificate of Competence (CoC) issued or endorsed by the Administrator. Refer to RMI Requirements for Seafarer Certification ([MI-118](#)).

13.5 Global Maritime Distress and Safety System (GMDSS) Logbooks

All yachts are required to keep records of communications relating to distress, urgency, and safety traffic. Records of important incidents connected with the radio service, regular positions of the yacht, and results of tests carried out on the radio equipment. Records must be stored on board and be available for inspection as required.

14.0 PUBLICATIONS

Yachts shall carry the most up-to-date and applicable version¹⁶ of the below Table 25 list of publications, based on the tonnage of the yacht as indicated. Please note these requirements represent the minimum in terms of compliance. Refer to *Requirements on Carriage of Publications On Board Ships* ([MN 1-000-3](#)).

¹⁶ Please note, in determining what version is applicable, a number of factors need to be taken into account, including but not limited to the date that the keel of the yacht was laid.

Table 25

Publication	up to 299 GT	300 to 399 GT	400 to 499 GT
COLREGS	✓	✓	✓
IAMSAR Vol. III	✓	✓	✓
Code of Signals	✓	✓	✓
ILLC	R*	R*	R*
ICS	✓	✓	✓
ISPS	-	R*	R*
MARPOL**	-	-	✓
MI-103	✓	✓	✓
MI-300	✓	✓	✓
NAUTAL	✓	✓	✓
NAUTCH-P	✓	✓	✓
NAUTCH-E	✓	✓	✓
SAILING DIRECTIONS-E	✓	✓	✓
SAILING DIRECTIONS-P	✓	✓	✓
TIDE TABLES-P	✓	✓	✓
TIDE TABLES-E	✓	✓	✓
LIGHT LIST-P	✓	✓	✓
LIGHT LIST-E	✓	✓	✓
NTVRP	-	-	✓
SOLAS	-	✓	✓
STCW	✓	✓	✓
STMAN	✓	✓	✓

* *R = Recommended*

** *PYLCs of 400 GT and greater and all PYLCs that are certified to carry more than 15 persons, shall carry a copy of MARPOL.*

15.0 DECK EQUIPMENT FOR YACHTS OF 300 GT AND ABOVE

15.1 Equipment

Yachts will be considered to have adequate deck equipment on board if such equipment is approved and installed in accordance with the Rules of Class and complies with the requirements of this Code.

15.2 Anchors

A minimum of two anchors are required on all yachts, one of which shall be rigged and ready for use at all times. The deployment system shall be able to be fully operational when there is a power failure or capable of being manually operated.

15.3 Sailing Yachts

- .1 The sizing of anchors and cables for sailing yachts shall take into account the additional windage effect of the masts and rigging.
- .2 For square rigged sailing yachts, the guidance on the approximate increase in anchor mass and cable strength required is as follows:
 - (a) for yachts of less than 50 m in Length, typically 50% above the requirements for a typical motor yacht having the same total longitudinal profile area of hull and superstructure as the sailing yacht under consideration; and
 - (b) for square rigged sailing yachts of 50 m and more but less than 100 m in Length, the increase should be obtained by linear interpolation.

15.4 Towing Arrangements

Accessible, efficient, strong securing points shall be provided for the attachment of towlines for the yacht to tow and be towed, fore and aft, respectively.

16.0 MEDICAL STORES

16.1 General

- .1 All yachts shall carry medical stores as outlined by *Medical Care On Board Ship and Ashore: Medicine Chest, Recordkeeping and Responsibilities and Training for Medical Care* ([MN 7-042-1](#)), as applicable, which provides details of medicines and medical stores to be carried or their suitable equivalent.
- .2 Medical training requirements for the crew of the yacht are provided in the *RMI Requirements for Seafarer Certification* ([MI-118](#)).

17.0 YACHT-SHORE TRANSFER

17.1 Tenders

- .1 A tender shall be fit for its intended use.
- .2 A lifeboat or rescue boat may be utilized as a tender, provided that the craft, equipment, and its launching appliances are certified and in compliance with the LSA Code.

- .3 Safety equipment shall be provided on each tender as appropriate to its intended range and areas of operation. Such safety equipment shall include, but not be limited to, appropriately sized lifejackets for each person on board the tender, appropriate radio communications, a portable fire extinguisher, and a mechanical or portable foghorn or klaxon.
- .4 The tender itself shall be clearly marked with the number of persons that it can safely carry, and the name of the mother yacht.
- .5 In the case of crafts with gasoline powered engines, the safety requirements for the carriage of gasoline outlined in [§7.1](#) above shall be met.
- .6 An official TSC confirming an equivalence of safety shall be issued by an AR. This statement has a validity of five years, subject to required annual surveys being satisfactorily held.
- .7 It is the responsibility of the Master to ensure that the operations of any water craft belonging to the mother yacht of any type are in compliance with the rules and regulations imposed by the local port authorities for the area of operation, including any training as required.

17.2 Pilot Transfer Arrangements for PYLCs

- .1 Yachts engaged on voyages in the course of which pilots may be employed shall be provided with pilot transfer arrangements. These arrangements shall have due regard for the international standards of safe practice for the boarding and landing of pilots in accordance with SOLAS V.
- .2 Periodic inspections and tests to confirm proper construction, installation, operation, and maintenance of equipment for the boarding arrangements of pilots shall be carried out in accordance with *Pilot Transfer Arrangements* ([MN 7-041-3](#)).

18.0 HELICOPTER AND LANDING FACILITIES

All yachts, where helicopter operations to and from the yacht are performed, shall comply with the applicable rules and regulations in accordance with [Annex 2](#) of this Code.

19.0 SUBMERSIBLES

19.1 General Requirements

- .1 All submersibles to be installed on a yacht shall be designed and built in accordance with the Rules of Class and maintained in Class.
- .2 When installing a submersible, special consideration shall be given to the stability and structure of the yacht.

19.2 Lifting Appliances and Attachments

- .1 The design and construction of the lifting appliance(s) and their attachment to the structure of the yacht and the associated stowage of the submersible shall be in accordance with the Rules of Class or certified as suitable for their intended use.
- .2 Lifting appliances and associated equipment installed on equipment where “man-riding” is required, shall be maintained and tested in accordance with §19.3 of this Chapter.
- .3 Where no “man-riding” is required, the equipment shall be maintained and tested to the recommendations as specified in *Voluntary Compliance with ILO Convention No. 152 (TC 3)*.

19.3 Operation

- .1 The safe operation of the submersible is the responsibility of the Master.
- .2 The Master shall ensure that the operator of the submersible has had the proper training and is certified to operate the submersible.
- .3 An operations manual shall be available on board the yacht. The manual shall contain, as a minimum, the lowering and recovery procedures, fire-fighting and safety procedures, and drills.

20.0 SAFE WORKING PRACTICES

20.1 Safe Work Aloft, Over the Side, at Heights, and on the Bowsprit of Sailing Yachts

- .1 When work aloft, over the side, at heights, or access to the rigging or bowsprit is likely to be an operational necessity, provisions shall be made to enable this work to be performed safely. The arrangements and procedures shall be documented in the Safety Management System (SMS) to the satisfaction of the Administrator.

- .2 The arrangements provided shall be based on established safe working practices for the type of yacht. The arrangements may include, but not be limited to:
- (a) safety nets below the bowsprit;
 - (b) safety grab-rails (pulpit) fixed along the bowsprit to act as handholds and safety points for safety harnesses;
 - (c) safety harnesses shall be provided for work aloft and on the bowsprit;
 - (d) sufficient footropes permanently rigged to enable the crew to stand on them while working out on the yards or on the bowsprit;
 - (e) safety jackstays (in metal) fixed along the top of the yards, to provide handholds and act as strong points for safety harnesses; and
 - (f) means of safely going aloft, such as:
 - (i) fixed metal steps or ladders attached to the mast;
 - (ii) traditional ratlines; or
 - (iii) bosun's chair.
- .3 The use of "rail and trolley" systems or similar systems for undertaking work over the side is permitted, provided that:
- (a) the systems installed comply with and are certified to the applicable BS standards for manufacturing, installation and pre- and post-installation testing for Class D Fall Protection Equipment;
 - (b) the systems are installed, maintained, and tested to the manufacturer's instructions. Testing shall be witnessed by the RO;
 - (c) the operations of these systems are fully described in the SMS manual for safe working practice; and
 - (d) a full risk assessment is carried out prior to the work carried out and that the crew members working with the equipment are trained and competent for the use of these systems.
- .4 Where "rail and trolley" systems are installed, the method of installation to the particular surface and underlying construction (substrate) needs to be tested in accordance with the requirements as per (a) and (b) above to be considered approved and suitable for supporting crew members working over the side.

.5 If a particular method of attachment of the systems to the substrate has been previously approved and documentary evidence can be provided only post-installation testing shall be required.

(a) For existing “rail and trolley” systems:

(i) if it cannot be confirmed that the design of the attachment to the substrate is identical to that used in the type approval process completed by the system’s manufacturer, or through approval of the design on another vessel, separate pre-installation testing is required to be satisfactorily completed prior to the system being installed.

(ii) if fitted with systems for which there is evidence that the system complies with the BS standards but without evidence that the installation was tested by an approved surveyor, the system shall not be used until the installation arrangements have been approved by the RO;

(iii) if fitted with systems for which there is evidence that the system is in compliance with the BS standard and there is evidence that the installation was approved but there is no evidence of post-installation testing, the systems shall be subject to post installation testing.

(b) For new “rail and trolley” systems:

In addition to the systems requiring type approval, the installation of the system to the substrate of the yacht shall be tested to meet the requirements of the latest edition of the BS standards in force at the time of the installation of the system.

20.2 Man-riding Cranes

Man-riding cranes must meet the following conditions:

.1 Design

Except those covered by [§10.1.2](#) above, deck cranes or other lifting appliances intended to be used for the purpose of “man-riding”, shall be certified as such through compliance with a recognized national or international standard deemed acceptable by the Administrator. Certification of such appliances shall be carried out to the satisfaction of the RO.

.2 Testing and Maintenance

Annual and five-year testing shall be in accordance with the original manufacturer’s instructions.

.3 Operations

Operations of the man-riding cranes and other lifting appliances must:

- (i) be in accordance with the original equipment manufacturer's operating instructions; and
- (ii) adhere to any restrictions established by the original equipment manufacturer or RO approving the equipment.

The operating instructions shall be part of the mini-ISM and posted locally to any controls along with any restrictions as per §20.2.3(ii).

20.3 Training Manual

- .1 The training manual shall include details of established safe working practices specific to the yacht, as well as guidance on:
 - (a) training for members of the crew;
 - (b) personal clothing and protection from injury;
 - (c) health and safety awareness;
 - (d) prevention of pollution; and
 - (e) life-saving appliances and fire-fighting equipment.
- .2 The training manual shall be yacht type specific and contain instructions for the actual equipment brands/types on board. The information regarding the life-saving appliances and fire-fighting equipment provided, and the best methods of survival shall be explained in easily understood terms and illustrations, where appropriate (reference should be made to SOLAS III/35, and SOLAS II-2/15).
- .3 The training manual shall be written in the working language of the yacht and in English.
- .4 The Master shall conduct drills and/or trainings for the crew. Refer to RMI Maritime Regulations ([MI-108](#)), regulation 7.41, as applicable. The drills and/or trainings shall also be documented in the SMS manual.

20.4 Instructions for On Board Maintenance

Instructions shall be provided describing the maintenance procedures for all safety and fire-fighting appliances in easily understood terms and illustrated wherever possible.

Refer to *Life-Saving Appliances and Systems* ([MN 2-011-37](#)) and *Maintenance and Inspection of Fire Protection Systems and Appliances* ([MN 2-011-14](#))

20.5 Safety Management System (SMS)

A simplified ISM system, a “Mini-ISM,” is required to be implemented in accordance with [Annex 1](#) of this Code. The Mini-ISM shall be to the satisfaction of the Administrator or its representative.

21.0 PASSENGERS

21.1 Limitations

- .1 PYLCs shall carry no more than 12 passengers regardless of the number of beds or berths provided.
- .2 Yachts may apply to the Administrator for a temporary authorization to carry more passengers, on an excursion of very limited duration and range, during which no additional passenger would be berthed on board for an overnight passage. In order to apply for such a dispensation, the owner or Master may request an *Application for Temporary Dispensation to Carry Additional Persons On Board* ([YTEC 01](#)) from the Administrator.

22.0 MANNING

22.1 General

When engaged in chartering, yachts shall comply with the Administrator’s minimum safe manning and seafarer certification requirements. When not engaged in chartering, these requirements do not apply.

22.2 Minimum Safe Manning

Refer to *Minimum Safe Manning Requirements for Vessels* ([MN 7-038-2](#)) for yacht minimum safe manning requirements.

22.3 Crew Certification

For information on crew certification refer to *RMI Requirements for Seafarer Certification* ([MI-118](#)), §7.0.

CHAPTER V:
YACHTS ENGAGED IN TRADE (YETs)

1.0 STATUTORY AND NATIONAL REQUIREMENTS

- 1.1 A private yacht that wants to charter for up to 84 days per calendar year in certain European Union (EU) waters must carry a YET Compliance Certificate and a Temporary COR YET. Refer to *Yacht Engaged in Trade* ([MG 1-11-2](#)) for the process of obtaining authorization as a YET.
- 1.2 YETs shall comply with all applicable RMI laws and regulations, including the Yacht Code as follows:
 - (a) Chapter I (as applicable); and
 - (b) Chapter II when carrying up to 12 passengers onboard; or
 - (c) Chapter III when carrying up to 36 passengers onboard; and
 - (d) Chapter V (in full).
- 1.3 Refer to RMI Yacht Compliance Requirements ([MI-103A](#)) for a comprehensive matrix of statutory and national requirements for YETs.

ANNEXES

**ANNEX 1:
MINI-SAFETY MANAGEMENT SYSTEM FOR YACHTS OF LESS THAN 500 GT**

1.0 Introduction

- .1 The purpose of this Annex is to provide the requirements for the development and implementation of an effective simplified management system (Mini-ISM) for yachts of less than 500 GT, where full certification to the International Safety Management (ISM) Code and the International Ship and Port Facility Security (ISPS) Code is not a requirement.
- .2 The objectives of the Annex are to ensure safety at sea, prevention of human injury or loss of life, avoidance of damage to the environment, and security of people and property.
- .3 The Mini-ISM shall comply with *Yacht “Mini-ISM”* ([MN 2-011-49](#)).

2.0 General

Each Mini-ISM shall include the following:

- .1 Health, Safety, Security, and Environmental Protection Policy.

This must address the issues of health, safety, security, and the environment as they affect the ISM Code Company (the “Company”) and its staff, both ashore and afloat. The objectives of the Company should be:

- (a) to provide for safe practices in yacht operation and a safe working environment;
 - (b) to establish safeguards against all identified risks; and
 - (c) to continuously improve management skills of personnel ashore and on board yachts, including preparing for emergencies related both to health, safety, security, and environmental protection.
- .2 Procedures to ensure safe operation of yachts in compliance with the regulations and rules.
 - (a) The management system shall ensure:
 - (i) compliance with mandatory rules and regulations; and

- (ii) that applicable codes, guidelines, and standards recommended or required by the IMO, Administrator, Classification Societies, and maritime industry organizations are taken into account.
 - (b) The Company shall establish procedures to ensure that safe working practices are carried out in the operation of the yacht. These may be in the form of checklists which can be followed by all personnel ashore and on board.
 - (c) For some yachts, it may be appropriate to have permanently exhibited checklists, e.g., in the wheelhouse for navigational items. Alternatively, in a smaller yacht, the record could take any suitable form, such as a diary as distinct from a specially printed logbook.
 - (d) Electronic recordkeeping for the purpose of the ISM is acceptable. Any electronic record keeping system shall be in accordance with *Electronic Record Books and Logbook Systems* ([MN 7-041-5](#)).
- .3 Effective lines of communication between personnel, ashore and on board.

Responsibility and authority of each employee should be clear. This may be best illustrated in a simple diagram, showing the hierarchy on board and ashore.

.4 Procedures for reporting accidents and incidents.

The requirement for reporting accidents should be well understood by all personnel and in so doing improve the safety and security culture practiced on board. Reference *Piracy, Armed Robbery, and the Use of Armed Security* ([MN 2-011-39](#)) and *Notification and Reporting of Marine Casualties, Marine Incidents, Occurrences and Offenses* ([MG 6-36-2](#)).

.5 Procedures for responding to emergency situations.

- (a) There shall be clearly stated procedures for responding to emergency situations. These may include but not be limited to:
 - (i) fire;
 - (ii) collision;
 - (iii) grounding;
 - (iv) security / violent act;
 - (v) main propulsion or steering failure; and

(vi) Man Overboard.

(b) Checklists may be useful in this regard.

3.0 Health, Safety, Security, and Environmental Protection Policy

- .1 One or more competent persons shall be delegated to take responsibility for health, safety, security, and environmental protection. That person or persons shall be clearly identified. It is the responsibility of the owner/operator to ensure that the policy is complied with and that the responsibilities are understood.
- .2 The Company/owner shall develop a policy on prevention of alcohol and drug abuse.
- .3 All personnel both ashore and on board have a duty to exercise due diligence with regard to themselves and other persons who may be affected by their acts or omissions.
- .4 It is essential that, in the event of an emergency, there is the ability to communicate with the emergency services via a shore base. The shore base may be the Company office ashore, the local port authorities, police or fire department, or another office as may be agreed between the yacht and the shore base.

4.0 Responsibilities and Authority

The Master must have authority at all times to make decisions with regard to the safety and security of the yacht and the persons on board. To ensure that there is no ambiguity regarding the authority of the Master, there shall be a simple written statement to this effect. It should emphasize the Master's overriding authority and the responsibility to make decisions with respect to health, safety, security, and pollution prevention, and to request assistance as may be necessary.

5.0 Resources, Personnel, and Training

- .1 All personnel shall receive training appropriate to the tasks they are assigned and undertake. It is the responsibility of the Company/owner to ensure that this training is given and that the personnel have an understanding of the relevant regulations and rules.
- .2 As a minimum, this means:
 - (a) for the Master, the relevant qualifications; and
 - (b) for the crew, relevant qualifications and any additional training appropriate to their designated duties.

- .3 Prior to the first occasion of working on the yacht, each employee must receive appropriate familiarization training and proper instruction in onboard procedures. This could include, but not necessarily be limited to:
 - (a) mooring and unmooring;
 - (b) launching and recovery of survival craft;
 - (c) evacuation from all areas of the yacht;
 - (d) donning of lifejackets;
 - (e) use and handling of fire-fighting equipment; and
 - (f) security prevention / response.

6.0 Onboard Procedures

Simple procedures shall be developed for the operation of the yacht. These should include, but not be limited to:

- (a) testing of equipment, including main steering gear, prior to commencing a voyage;
- (b) navigation and handling of the yacht;
- (c) maintenance routines;
- (d) bunkering operations;
- (e) watertight / weather-tight integrity;
- (f) stability of the yacht;
- (g) conduct of passengers and crew while on board; and
- (h) security of the yacht.

7.0 Emergency Preparedness

- .1 All emergencies likely to be encountered by the yacht should be considered. Drills, as per the RMI Maritime Regulations ([MI-108](#)), shall be carried out in the preparation for such emergencies and possible evacuation of the yacht.

- .2 Where possible, all personnel should be involved in these drills, both ashore and on board.
- .3 The roles and responsibilities of all personnel in an emergency situation shall be defined.
- .4 The drills shall be recorded. The names of those who participated shall also be documented.

8.0 Reporting of Accidents

Yachts operating under the Code are required to report any accidents to the Administrator. The Company must have a procedure in place for submitting such reports. Additionally, all accidents and near accidents shall be recorded and reported to the operator/owner, who shall implement corrective and preventive action.

9.0 Maintenance of the Yacht and Its Equipment

- .1 Maintenance of the yacht and its equipment is an essential ingredient of safety and security management. The equipment shall be checked and tested daily when in use, in addition to the tests referred to in §[6.0](#) of this Annex 1.
- .2 There should be procedures for a more detailed inspection and maintenance program of the yacht and its equipment.
- .3 The frequency of the inspections should be determined by the owner/operator, but every event should be recorded, as applicable.
- .4 A checklist could be employed as an aide for the inspection of equipment.

10.0 Compliance Verification, Review, and Evaluation

- .1 During initial compliance verification the Mini-ISM system and documents are subject to review by an AR.
- .2 During the annual and renewal compliance verifications the proper implementation of the SMS requirements shall be reviewed by the AR.
- .3 Every Company/owner shall undertake a review of the management system (Mini-ISM) as per *Yacht "Mini-ISM"* ([MN 2-011-49](#)).

ANNEX 2: HELICOPTER AND LANDING FACILITIES

This Annex describes the minimum standards for helicopter landing facilities on board any yacht to which the Code applies, where helicopter operations to or from the yacht are performed.

It does not address the operation of a helicopter outside the scope of the landing area or associated helicopter facilities on board the yacht.

1.0 General

- .1 The helicopter landing areas (HLAs) shall be located on an appropriate area of the weather or superstructure deck or on a purpose built landing area permanently attached to the yacht or structure.
- .2 A helicopter operations manual which contains, at a minimum, the helicopter operation policies and restrictions/limitations, landing and take-off procedures, fire-fighting and safety procedures, and drills shall be available on board. This manual shall also reflect §1.0.3 and §4.0 below. This manual shall form part of the yacht's Safety Management System (SMS) or Mini-ISM.
- .3 The HLA shall be designed taking into account the specifications of the largest helicopter that is intended to be used, in order to ensure the helicopter is afforded sufficient space for safe operations in all conditions.
- .4 It is highly advisable that a helicopter connected to a mother yacht be included on the *Official Record of Ancillary Vessels and Other Appurtenances* (MI-200-A) for that mother yacht.

2.0 Certification

- .1 In regard to the design, structural strength, refueling, fuel storage, hangar facilities and means of escape, the HLA shall be designed and constructed in accordance with SOLAS II-2/18 and the Rules of Class.
- .2 Fire-fighting appliances for HLAs shall be in accordance §3.0 below.
- .3 The *Aviation Inspection Body and Recognized Organization Responsibility Matrix for Certification of Helicopter Landing Areas* ([YTC 3](#)) outlines the scope of shared responsibilities between the Classification Society and the Aviation Inspection Body (AIB) in regard to plan reviews, surveys, and certification of HLAs on all yachts.
- .4 The Classification Society shall issue a Statement of Compliance for the HLA and associated facilities in accordance with [YTC 3](#). The Statement of Compliance

shall reflect any applicable operational limitations and/or restrictions imposed by the Classification Society.

- .5 Every HLA and its associated facilities shall be assessed and certified as suitable for helicopter operations by an AIB in accordance with their standards and recommended procedures and the applicable scope of responsibility outlined in *Aviation Inspection Body and Recognized Organization Responsibility Matrix for Certification of Helicopter Landing Areas* ([YTC 3](#)). Where deemed necessary, the AIB may implement the application of any appropriate operational limitations and/or restrictions.
- .6 Once the Statement of Compliance has been issued and the AIB has assessed the HLA to be suitable in accordance with §2.3 above, an HLA Certificate shall be issued by the AIB and is subject to revalidation at a minimum of every 24 months from the date of the inspection.
- .7 Upon request from the shipyard, the AIB may issue a Helicopter Landing Area Technical Certificate (HLATC). This certificate solely indicates the compliance of construction, design and firefighting appliances. This HLATC shall not be regarded as an Helicopter Landing Area Certificate (HLAC) and not be used for operational purposes.
- .8 An HLAC recognized by another Administration may be accepted by the Administrator for the term of validity. Renewal inspection and certification may only be carried out by an AIB listed in *Organizations Acting on Behalf of the Republic of the Marshall Islands Maritime Administrator* ([MG 2-11-15](#)).

3.0 Fire-Fighting

- .1 Fire-fighting appliances shall be in accordance with the FSS Code. However, for an HLA restricted to only helicopters using aviation kerosene, alternative standards contained in §3.1 and §3.2 below may be applied.
- .2 All equipment should be ready for immediate use on, or in the immediate vicinity of, the landing area whenever helicopter operations are being conducted. All equipment should be located at points having immediate access to the landing area.

3.1 Primary Fire Extinguishing Agent – Foam

- .1 The HLA shall have a fixed foam application system (FFAS) with an automatic or semi-automatic method used for the distribution of extinguishing agent to contain and bring a fire under control in the shortest possible time, while protecting the means of escape for personnel to quickly and easily alight clear of the landing area to a place of safety. An FFAS may include, but is not necessarily limited to, a fixed monitor system (FMS) or a deck integrated firefighting system (DIFFS).

- .2 Taking into account that the effectiveness of any FFAS is the speed of initiating a response in addition to the effectiveness of that response, the time measured from the system being activated to actual production at the required application rate shall be less than 15 seconds.
- .3 The FFAS shall be of adequate performance and be suitably located to ensure an effective application of foam to any part of the landing area irrespective of the wind strength/direction or accident location when all components of the system are operating in accordance with the manufacturer's technical specifications for the equipment.
- .4 The application rate is dependent on the types of foam concentrate. Foam concentrates shall be compatible with seawater and meet at least International Civil Aviation Organization (ICAO) performance level 'B' or performance level 'C'. Level 'B' foams should be applied at a minimum application rate of 5.5 L per m² per minute. Level 'C' foams should be applied at a minimum application rate of 3.75 L per m² per minute.
- .5 The overall capacity of the foam system should exceed that which is necessary for the initial suppression and extinction of the fire. Five minutes of foam application capability is considered to be reasonable.
- .6 Low expansion foam concentrates can be applied in either aspirated or non-aspirated form. Wherever a non-aspirated FFAS is selected during design, additional hose lines capable of producing aspirated foam for post-fire security/control shall be provided.
- .7 Where an FMS is installed, consideration shall be given to the loss of a (downwind) foam monitor either due to limiting weather conditions or as a result of a crash situation occurring. The design specification for an FMS shall ensure remaining monitor(s) are capable of delivering finished foam to the landing area at or above the minimum application rate. When an FMS is selected as the FFAS, there shall also be the ability to deploy at least two hand-controlled foam branch pipes for the application of aspirated foam at a minimum rate of 225 to 250 L/minute through each hose line. A single hose line, capable of delivering aspirated foam at a minimum application rate of 225 to 250 L/minute, may be acceptable where it can be demonstrated that the hose line is of sufficient length, and the hydrant system of sufficient operating pressure, to ensure the effective application of foam to any part of the landing area irrespective of wind strength or direction. The hose line(s) provided should be capable of being fitted with a branch pipe able to apply water in the form of a jet or spray pattern for cooling, or for other specific firefighting tactics.
- .8 Where DIFFS are installed as an alternative to an FMS, the systems typically should consist of a series of pop-up nozzles with both a horizontal and vertical component, designed to provide an effective spray distribution of foam to the

whole of the landing area and protection for the helicopter suitable for a range of weather conditions. When a DIFFS capable of delivering foam in a spray pattern to the whole of the landing area is selected, additional hand-controlled foam branch pipes may not be necessary to address any residual fire situation. Residual fire may be tackled with the use of suitable hand-held extinguishers. The precise number and lay out of pop-up nozzles will be dependent on the specific landing area design, particularly the dimensions of the landing area. Nozzles may not be located adjacent to helideck egress points as this may hamper quick access to the helideck by rescue crews and/or impede occupants of the helicopter from escaping to a safe place away from the landing area.

- .9 Notwithstanding the requirements of §3.8 above, the number and layout of nozzles should be sufficient to provide an effective spray distribution of foam over the entire landing area with a suitable overlap of the horizontal spray component from each nozzle, assuming calm wind conditions. The performance specification for a DIFFS shall ensure that if at least one of the nozzles is rendered inactive, the system will remain fit-for-purpose, and is able to bring a fire associated with a crashed helicopter under control within one minute measured from the time the system is producing foam at the required application rate.
- .10 In lieu of meeting the requirements in this §3.1, yachts of less than 500 GT fitted with an HLA limited to operating single-turbine engine helicopters with a maximum seating capacity of seven people, may have a suitable foam system consisting of foam making branch pipes capable of delivering foam to all parts of the HLA in all weather conditions in which the helicopter can operate. The system will be capable of delivering a discharge rate of at least 250 L per minute for a minimum of five minutes. The principal agent shall be suitable for use with seawater and conform to International Civil Aviation Organization (ICAO) level B or level C performance standards. At least two nozzles of an approved dual-purpose type (jet/spray) and hoses sufficient to reach any part of the HLA are required.

3.2 Complementary Fire Extinguishing Agents

- .1 In addition to the primary fire extinguishing agent specified in §3.1 above, the yacht shall provide complementary agents for the HLA.
- .2 Dry chemical powder is recommended as the primary complementary agent. The quantities are listed in Table 26 below. The dry powder system should have the capability to deliver the agent anywhere on the landing area and the discharge rate of the agent should be selected for optimum effectiveness of the agent. Containers of sufficient capacity to allow continuous and sufficient application of the agent should be provided. Dry chemical powder should be of the foam-compatible type.

- .3 A quantity of gaseous agent is recommended in addition to the use of dry powder as a secondary complementary agent. A quantity of gaseous agent should be provided with a suitable applicator for use on engine fires. The quantities are listed in Table 26 below. Due regard shall be given to the requirement to deliver gaseous agents to the seat of the fire at the recommended discharge rate.
- .4 All applicators shall be designed and capable of manual operation and fitted with a mechanism which allows them to be hand-controlled.

Table 26

	Dry Chemical Powder	Gaseous Agent (CO₂)
HLA ≤ 16 m	23 kg From 1 or 2 extinguishers	9 kg From 1 or 2 extinguishers
HLA > 16 m ≤ 24 m	45 kg From 1,2 or 3 extinguishers	18 kg From 1 or 2 extinguishers

4.0 Operations

- .1 It is the responsibility of the Master in conjunction with the helicopter pilot to determine whether any helicopter operations can occur on the yacht. Factors to take into account in making this determination include, but are not limited to, the weather, sea state, and any other limiting conditions, as well as whether the HLA is fit for take-off and landing operations. Any limits defined in the helicopter operations manual shall also be taken into account.
- .2 The helicopter pilot is responsible for ensuring full compliance with the requirements of the helicopter’s registering Administration and the requirements of the local airspace authorities in which the helicopter operates.
- .3 All crew assigned to duties with regards to the helicopter operations on board the yacht shall undergo familiarization training. This training shall include, but is not limited to, fire-fighting, rescue operations, and other emergency operations, as well as appropriate communication procedures.
- .4 At least one properly trained Helicopter Landing Officer (HLO) shall be assigned. This person shall be trained by an appropriate training provider and suitably documented.
- .5 Fire-fighting personnel consisting of at least two persons trained for rescue and fire-fighting duties shall be immediately available at all times during helicopter flight operations. This training shall be suitably documented.

- .6 If the yacht is equipped with helicopter refueling facilities, at least one crew member shall be trained for the handling and quality control procedures of the aviation fuel carried on board, and this training shall be suitably documented.
- .7 The duties, responsibilities, and procedures for each of the crew members required in §4.0.4 to §4.0.6 above shall be defined in the helicopter operations manual.
- .8 The yacht shall ensure that, during landing and takeoff, adequate communications have been established with the helicopter pilot.
- .9 Emergency scenarios shall be addressed in the SMS.
- .10 Regular drills for helicopter emergency scenarios shall be carried out in conjunction with the SMS. These drills shall be recorded in the appropriate drill records.

ANNEX 3: SIMPLIFIED TONNAGE MEASUREMENT METHOD

A simplified method of measurement may be used, if necessary, for private yachts that are not required to and do not have their tonnage calculated in accordance with the International Convention on Tonnage Measurement of Ships, 1969 (ITC).

1.0 Applicability

This simplified tonnage assignment criterion is applicable to monohull and multihull yachts **less than 24 m in length** of normal proportions and form. A Recognized Organization (RO) or a Qualified Individual (QI) may perform the admeasurement.

2.0 Definitions – for the purpose of this simplified measurement scheme only

- .1 **Length Overall (L)** – Distance in meters measured along the main deck at the centerline of the yacht from the fore side of the hull to the aft side of the transom. Bowsprits, stern mounted diving platforms, and other appendages that do not contribute to the volume of the yacht are not to be included in this measurement.

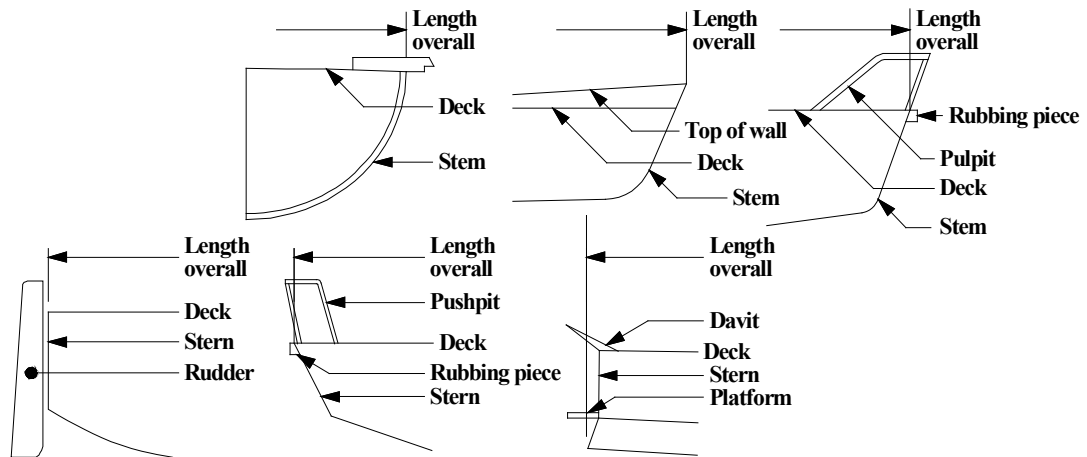

- .2 **Breadth (B)** – Maximum width of the yacht, excluding rub rails and deck caps, measured in meters from the outside of the hull on one side to the outside of the hull on the other side of the yacht.
- .3 **Depth (D)** – Maximum depth of the yacht measured at or near midships in meters vertically from the top of the deck at the side to the underside of the hull where it meets the keel or to the point where the projected line of the bottom intersects the yacht's centerline. For open boats, such as rigid inflatable boats (RIBs) and center console boats, the depth shall be measured from the top of the gunwale or buoyancy tube to the underside of the hull where it meets the keel.

.4 **Volume** – The product of Length, Breadth, and Depth.

3.0 Measurements

- 1 All lengths and depths shall be measured in a vertical plane at centerline and breadths shall be measured in a line at right angles to that plane. All dimensions shall be expressed in meters.
- 2 For multihull yachts, each hull shall be measured separately for overall length, breadth, and depth and the yacht as a whole shall be measured.

4.0 Calculations

Gross Tonnage (GT):

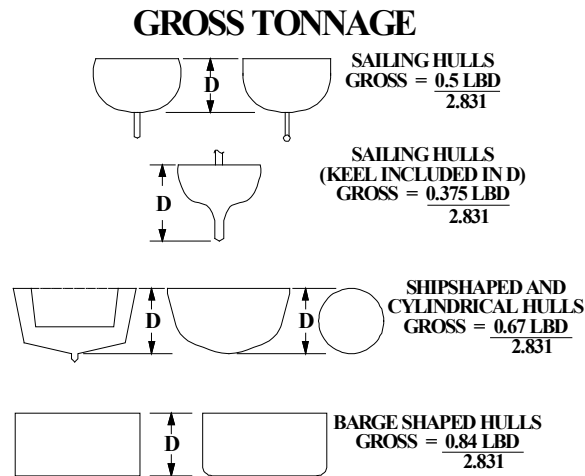

Net Tonnage (NT):

Sailing Hulls with internal machinery: $\text{NT} = 0.9 \times \text{GT}$

Ship-Shaped, Cylindrical, or Barge Shaped Hulls with internal machinery:
 $\text{NT} = 0.8 \times \text{GT}$

Hulls with external machinery: $\text{NT} = \text{GT}$

5.0 Multihull Yachts

The GT of a multihull yacht is the sum of the GT of each hull as calculated using the formulas listed above. For example:

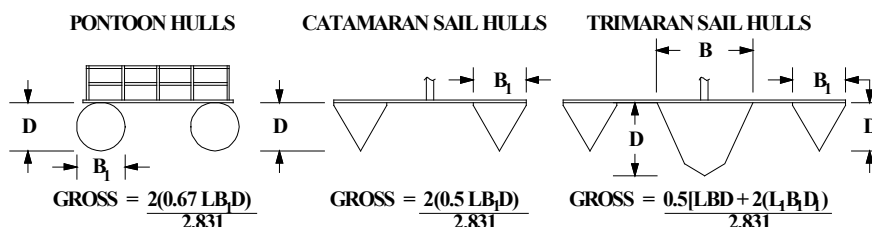

Where L is the length of the center hull and L₁ is the length of the outside hulls.

6.0 Deck Structures

- .1 For most yachts, the formulas in §4.0 and §5.0, above, account for the volumes of deck structures such as cabins and deckhouses. However, if deck structures are excessive in size, the GT is calculated by adding the principal deck structure tonnage to the GT of the hull(s).
- .2 Deck structures are considered excessive in size if the tonnage of the principal deck structure calculated using the formula below is equal to or exceeds the GT of the hull(s).

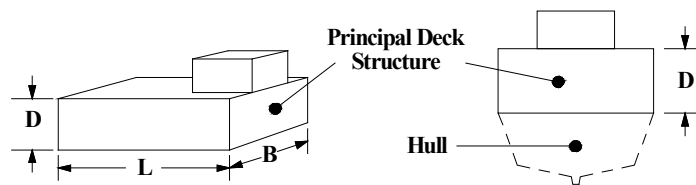

$$\text{Principal Deck Structure Tonnage} = L \times B \times D / 2.831$$

REPUBLIC OF THE MARSHALL ISLANDS
YACHT CODE

ISSUE AND REVISION HISTORY

Rev	Date mmm/year	Description	Entered By	Entered mm/dd/yy
2021 series Rev. 1	May/2021	Updated Ch. I §1.0 (Introduction); updated Ch. I §2.1.1 (Effective Date); updated Ch. I §2.1.4 (PYLCs); updated Ch. I §2.1.5.1 and §2.1.5.2 (YETs), added; updated Ch. I §2.3.1 and §2.3.2 (Equivalent Standards); updated Ch. I §2.4.1, §2.4.2, §2.4.3, and §2.4.4 (Operational Limitations); updated Ch. I §2.5 (Coastal State Requirements); updated Ch. I §2.7.1 and §2.7.2 (Administrator Notices, Advisories, and Circulars); updated Ch. I §2.8 (Yacht Contact Email Address); updated Ch. I §2.10 (Carriage Supernumeraries), and renumbered; updated Ch. I §3.0, updated definition of (2010 FTP Code), added definition of (Daughter craft), updated definition of (FSS Code), added definition of (GNSS), added definition of (HLATC), updated definition of (Immersion Suit), updated definition of (Main vertical zone), added definition of (Man-Riding Crane); added definition of (QI), added definition of (RFAs), updated definition of (YET); updated Ch. II §1.3 (MARPOL); updated Ch. II §1.3.2.2 (MARPOL Annex IV); updated Ch. II §1.3.3.3 (MARPOL Annex V); updated Ch. II §1.3.4 (MARPOL Annex VI); updated Ch. II §1.4.2 (Anti-Fouling); updated Ch. II §1.5 (BWM Convention) updated Ch. II §1.11.3 (ISM Code); added Ch. II §1.14 (IGF Code); added Ch. II §1.15 (IHM); updated Ch. II §2.1.2, (Survey Standards); updated Ch. II §2.2 (Survey Requests), renumbered; updated Ch. II §3.1 (Maintaining Compliance with this Code - General); updated Ch. II §3.2.1, §3.2.3, §3.2.6, and §3.2.7 (Statutory Compliance and RMI Certification); updated Ch. II §3.3 (Commercial Yachts Constructed in Accordance with the Code); updated Ch. II §4.1.4 (General Requirements); updated Ch. II §4.3.2, §4.3.4, §4.3.5, §4.3.6, §4.3.7, and renumbered (Watertight Bulkheads); updated Ch. II §4.4.1 and §4.4.2 (Enclosed Compartments); added Ch. II §4.5.1 and §4.5.2 (Underwater Observation Spaces); updated Ch. II §5.1.2 and renumbered (Conditions of Assignment - General); updated Ch. II §5.22 (Hatchways Open at Sea); updated Ch. II §5.3.2, §5.3.4, §5.3.6, and renumbered (Doorways and Companionways); updated Ch. II §5.4.5 (Skylights); updated Ch. II §5.5.1 - §5.5.6,	M.Sparks	05/11/2021

	<p>and renumbered (Glazed Openings), renumbered; updated Ch. II §5.6.6 (Ventilators and Exhausts); updated Ch. II §5.7.2 (Air Pipes); updated Ch. II §5.10 (Underwater Lights); updated Ch. II §5.12.1, and §5.12.3 (Bulwarks and Guard Rails); updated Ch. II §6.1.3, §6.1.5, §6.1.6, and §6.1.7 (Freeboard - General); updated Ch. II §6.2.1 (Freeboard Mark and Loading); updated Ch. II §6.3.1.3 (Draft Marks); updated Ch. II §6.3.2.1 (Load Line Marks); updated Ch. II §7.1.3 (Stability Intact and Damaged – General); updated Ch. II §7.2.2 (Equivalent Stability Standards); added Ch. II §7.2.3 and renumbered (High Speed Yachts); updated Ch. II §7.2.4 (Sailing Yachts); updated Ch. II §7.3.1, §7.3.2, and renumbered (Damage Stability); updated Ch. II §7.4.2, §7.4.3, §7.4.4, §7.4.6, and §7.4.7 (Elements of Stability); updated Ch. II §7.5.1 and §7.5.5 (Stability Documents); updated Ch. II §7.6.4, §7.6.5, and §7.6.6 (Major Refit or Alternations); updated Ch. II §8.1.3 (Sailing Yacht Rigging – General); updated Ch. II §8.2 (Masts and Spars); updated Ch. II §9.2 (New Yachts); updated Ch. II §9.10.7, §9.10.9, and §9.10.11 (Food Preparation and Storage Facilities); updated Ch. II §9.12.1, §9.12.2, §9.12.3, and §9.12.10 (Sleeping Accommodation); updated Ch. II §9.14.2 (Sanitary Facilities); updated Ch. II §9.17 (Office Space); updated Ch. II §10.1.1, §10.1.2, and §10.1.3); updated Ch. II §10.2.1, §10.2.6, and §10.2.8; updated Ch. II §10.3.3 and §10.3.6 (Steam Room – Thermal Suite); updated Ch. II §10.4.1 and renumbered (Fire Control Plans); updated Ch. II §11.3.9 (Ventilation); updated Ch. II § 11.4.3 and §11.4.4 (Means to Escape); updated Ch. II §11.5.4 and §11.5.6 (Materials); updated Ch. II §11.6.1 and §11.6.2 (Open Flame Gas Appliances and Recreational Fire Appliances); updated Tables 11 and 12, Note 8 (Service Spaces); updated Ch. II §12.4.5 (Openings in “A” Class Divisions); updated Ch. II §12.9.4 (Structural Integrity), updated Ch. II §12.11.9 (Ventilation Systems); updated Ch. II §12.13.1 (Accommodation and Service Spaces); updated Ch. II §12.13.2 (Machinery Spaces); updated Ch. II §12.25.1 and §12.25.2 (Open Flam Gas Appliances and Recreational Fire Appliances); updated Ch. II §13.1.5 (Machinery for Yachts of Less than 500 GT – General Requirements); updated Ch. II §13.4.2 (Periodically Unmanned Machinery Spaces); updated Ch. II §13.4.3.5 (Pumping and Piping Arrangements); added Ch. II §13.5.5 (Battery Systems for (Hybrid) Propulsion); updated Ch. II</p>		
--	--	--	--

	<p>§14.1.3 (Machinery for Yachts 500 GT and Above – General Requirements); updated Ch. II §14.3.2 (Bilge Pumping Arrangements); added Ch. II §14.5 (Battery Systems for (Hybrid) Propulsion); updated Ch. II §15.1.3 and §15.1.4 (Fire-Fighting Equipment Yachts of Less than 500GT); updated Ch. II §15.2.4.1, §15.2.4.3, and §15.2.4.6 (Portable Fire Extinguishers for Use in the Accommodation and Service Spaces); updated Ch. II §15.2.5.1 (Fire Extinguishing in Machinery Spaces); updated Ch. II §15.2.6 (Additional Fire Appliances); updated Ch. II §16.4. (Fire-Fighting Equipment – Commercial Yachts 500GT and Above); updated Ch. II §17.1.1.4 §17.1.1.5, §17.1.1.6, and renumbered (Life-Saving Appliances); updated Ch. II §17.1.2.3 (Launching Appliances); updated Ch. II §17.2.1.4 (Lifeboats); updated Ch. II §17.2.2.1, §17.2.2.7, and renumbered(Life Rafts); updated Ch. II §17.2.3.3 (Recovery of Persons from the Sea); updated Ch. II §17.2.4.1-§17.2.4.6 (Rescue Boats); updated Ch. II §17.2.6.3 (Lifejackets) updated Ch. II §17.2.7.1, §17.2.7.3, §17.2.7.4, §17.2.7.5, §17.2.7.6 (Immersion Suits), and renumbered); updated Ch. II §17.2.13.1 (Lighting); updated Ch. II §18.1.4 (Navigational Lights, Shapes, and Sound Signals – General); updated Ch. II §19.2.1.3 (Standard Magnetic Compass); updated Ch. II §19.2.3 (GNSS); updated Ch. II §19.2.4.2 (AIS); updated Ch. II §19.4.5 (Bridge Visibility); updated Ch. II §20.1.1 - §20.1.1.5, added Table 15, and renumbered (Radio – General); updated Ch. II §20.3 (Watches); updated Ch. II §26.2.2 and §26.2.3 (Lifting Appliances and Attachments); updated Ch. II §27.1.1 – §27.1.4 (Safe Work Aloft, Over the Side, at heights, and on the Bowsprit of Commercial Sailing Yacht); added Ch. II §27.2 (Man-Riding Cranes); updated Ch. II §27.3 (Noise and Vibration); updated Ch. II §27.6 (SMS); updated Ch. II §27.7 (Maritime Security); updated Ch. II §28.1.2 (Limitations); updated Ch. III §1.0.4 (Statutory and National Requirements); updated Ch. III §1.3 (MARPOL); updated Ch. III §1.4.2 (Anti-Fouling); updated Ch. III §1.5 (BWM Convention); added Ch. III §1.14 (IGF Code); added Ch. III §1.15 (IHM); updated Ch. III §2.2 and renumbered Survey Requests); updated Ch. III §3.1 (Maintaining Compliance with the Code – General); updated Ch. III §3.2.1, §3.2.4, and §3.2.5 (Statutory Compliance and RMI Certification) ; added Ch. III §3.3 (PAXYs Constructed in Accordance with the Code); updated Ch. III §4.1.5 (Yacht Shore Transfer – General); updated Ch. III §6.2.2 and §6.2.3</p>		
--	--	--	--

	<p>(Lifting Appliances and Attachments); updated Ch. III §7.1.1 - §7.1.4 (Safe Work Aloft, Over the Side, at heights, and on the Bowsprit of Sailing PAXYs) ; added Ch. III Safe Work Aloft, Over the Side, at heights, and on the Bowsprit of Sailing PAXYs); added Ch. III §7.2 (Man-Riding Cranes); updated Ch. III §7.3.1 (Noise and Vibration); updated Ch. III §7.6 (SMS); updated Ch. III §7.7 (Maritime Security); updated Ch. III §8.1 (Limitations); updated Ch. IV §1.3 (MARPOL); updated Ch. IV §1.3.2.3 (MARPOL Annex IV); updated Ch. IV §1.3.3.3 (MARPOL Annex V); updated Ch. IV §1.5 (BWM Convention)added Ch. IV §1.8 (IGF Code); updated Ch. IV §2.1.2 (Survey Standards); updated Ch. IV §2.2 (Survey Requests); updated Ch. IV §3.1 (Maintaining Compliance with this Code – General); updated Ch. IV §3.2.3 (Statutory Compliance and RMI Certification); updated Ch. IV §3.3 (PYLCs Constructed in Accordance with the Code); updated Ch. IV §4.1.1 and renumbered (Conditions of Assignment – General); updated Ch. IV §4.2.2 (Hatchways Open at Sea); updated Ch. IV §4.3.2 and §4.3.6 (Doorways and Companionways Located Above the Weather Deck for PYLCs Category 0 and 1); updated Ch. IV §4.4.1 and §4.4.5; added Ch. IV §4.5 (Glazed Openings); updated Ch. IV §4.6.6 (Ventilators and Exhausts for PYLCs Category 0 and 1); updated Ch. IV §4.7 (Air Pipes for PYLCs Category 0 and 1); Ch. IV §4.9.4 (Materials for Valves and Associated Piping); updated Ch. IV §4.10 (Underwater Lights); updated Ch. IV §4.13.3 (Bulwarks and Guard Rails); updated Ch. IV §4.14 (General Equivalence); updated Ch. IV §5.1.2, §5.1.3, and §5.1.4 (Stability Intact and Damaged – General); updated Ch. IV §5.2.1 (Motor Yachts); added Ch. IV §5.2.3 (High Speed Yachts); updated Ch. IV §5.2.4 (Sailing Yachts); updated Ch. IV §5.3.1 and §5.3.2 (Damage Stability); updated Ch. IV §5.4.2, §5.4.3, §5.4.4, §5.4.6, and §5.4.7 (Elements of Stability); updated Ch. IV §5.5.1 (Stability Documents); updated Ch. IV §5.6.4, §5.6.5, and §5.6.6 (Major Refit or Alterations); added Ch. IV §6.0 (Sailing Yacht Rigging); updated Ch. IV §7.1.1, §7.1.2, and §7.1.3 (Stowage of Gasoline, Aviation Fuel, and Other Highly Flammable Liquids); updated Ch. IV §7.3.9 (Ventilation); updated Ch. IV §7.4.3 and §7.4.4 (Means to Escape); updated Ch. IV §7.5.1 and §7.5.2 (Open Flame Gas Appliances and Recreational Fire Appliances); updated Ch. IV §7.7.1, §7.7.2, §7.7.3 (Fire Detection and Fire Alarm System); updated Ch. IV §8.1.4</p>		
--	---	--	--

	<p>(Machinery for PYLCs of 300 GT and Above – General Requirements); updated Ch. IV §8.4.3.5 (Pumping and Piping Arrangements); added Ch. IV §8.5.5 (Battery Systems for (Hybrid) Propulsion); update Ch. IV §9.1 (Fire Fighting Equipment for PYLCs – General Requirements); updated Ch. IV §9.2.3.4 (Fire Hoses and Nozzles); updated Ch. IV §9.2.4.1, §9.2.4.3, and §9.2.4.6 (Portable Fire Extinguishers for Use in the Accommodation and Service Spaces); updated Ch. IV §9.2.5.1 (Fire Extinguishing in Machinery Spaces); updated; Ch. IV §9.2.6,1 - §9.2.6.5 (Additional Fire Appliances); updated Ch. IV §10.1.1.1 and §10.1.1.4 (Life-Saving Appliances); updated Ch. IV §10.1.2.3 (Launching Appliances); updated Ch. IV §10.2.1.1, §10.2.1.7, and renumbered (Life Rafts); updated Ch. IV §10.2.3.1 - §10.2.3.7 (Rescue Boats); updated Ch. IV §10.2.5.3 (Lifejackets); updated Ch. IV §10.2.6.1 - §10.2.6.6 (Immersion Suits); updated Ch. IV §11.1.2 and §11.1.4 (Navigational Lights, Shapes, and Sound Signals - General); updated Ch. IV §12.2.1.3 (Standard Magnetic Compass); updated Ch. IV §12.2.2 (GNSS); updated Ch. IV §12.2.3.2 (AIS); updated Ch. IV §12.2.4 (Long-Range Identification and Tracking (LRIT) System); updated Ch. IV §12.3 (BNWAS); updated Ch. IV §12.4.2, §12.4.4, and §12.4.5 (Bridge Visibility); updated Ch. IV §13.1.1 - §13.1.5 (Radio – General); updated Ch. IV §15.2 (Anchors); updated Ch. IV §19.2 .2 and §19.2.3 (Lifting Appliances and Attachments); added Ch. IV §20.1.1 -§20.1.4 (Safe Work Aloft, Over the Side, and on the Bowsprit of Sailing Yacht PYLCs); added Ch. IV §20.2 (Man-Riding Cranes); updated Ch. IV §21.1.1 and §21.1.2 (Limitations); updated Ch. IV §22.1 (Manning – General); updated Ch. IV §22.2 (Minimum Safe Manning); updated Ch V §1.1, §1.2, §1.3 (Statutory and National Requirements); updated Annex I §1.0.3 (Mini-Safety Management System for Yachts of Less than 500 GT - Introduction); updated Annex I §2.0.2 (General); updated Annex I §10.3 and renumbered (Compliance Verification, Review, and Evaluation); added Annex II §1.0 - §4.0 (Helicopter and Landing Facilities); updated Annex III §1.0 (Simplifies Tonnage Measurement Method – Applicability); updated Annex III §2.3 (Depth); update to Annex III §4.0 and renumbered (Calculations); updated Annex III §6.0 (Deck Structures); & updated the TOC to reflect above changes.</p>		
--	--	--	--

2020 series Rev. 1	01/20	Updated Ch. II §17.1.1 (Life-Saving Appliances); updated Ch. II §17.1.2 (Launching Appliances); updated Ch. II §27.4 (Instructions for Onboard Maintenance); updated Ch. IV §9.1.1.3 (Life-Saving Appliances); updated Ch. IV §9.1.2.2 (Launching Appliances); and updated Ch. IV §19.2 (Instructions for Onboard Maintenance).; & updated the TOC to reflect above changes.	M. Sparks	01/01/20
2017 series Rev. 1	04/17	Removed Ch. I, §2.1.5 (Private Yachts); updated Ch. I, §2.2 (Effective Date); updated Ch. I, §2.5.2; added Ch. I, §2.11 (Carriage of Supernumeraries); added Ch. I, §2.12 (Supplement to the Code); updated Ch. I, §3.0; added definition of LOA; updated definition of Garbage, updated definition of Passenger, updated definition of Social Guest, updated definition of Supernumerary, and updated definition of Statement of International Convention Voluntary Compliance; edits to Ch. II, §1.3.2.2 (MARPOL Annex IV); updated Ch. II, §1.3.3.3 (MARPOL Annex V); updated Ch. II, §1.5, (BMW Convention); edits to Ch. II, §1.13.3 (MLC, 2006); edits to Ch. II, §9.11.4 (Water Service); edits to Ch. II, §9.12.4(d)(e)(f)(g)(h) (Sleeping Accommodation); renumbered Ch. I, §9.12 (Sleeping Accommodation); minor edit to Ch. II, §9.14.2 (Sanitary Facilities); minor edit to Ch. II, §10.1.7 (Stowage of Gasoline, Aviation fuel, and other Highly Flammable Liquids); edits to Ch. II, §10.4.1 (Fire Control Plans); renumbered Ch. II, §10.4 Fire Control Plans; removed Ch. II, §11.3.1 (Ventilation); update to Ch. II, §11.3.9 (Ventilation); renumbered Ch. II, §11.3 (Ventilation); updated Ch. II, §11.4.3 (Means to Escape); updated Ch. II, §13.3.1 (Steering Systems); added Ch. II, §13.5.4.5 (Batteries); updated title of Ch. II, §27.0 (Safe Working Practices); edits to Ch. III, §1.0 (Statutory and National Requirements); updated Ch. III, §1.3.2.2 (MARPOL Annex IV); updated Ch. III, §1.3.3.3 (MARPOL Annex V); minor edit to Ch. III, §1.10.2.2 (Classification and Certification); edits to Ch. III, §1.13.3 MLC, 2006; updated title of Ch. III, §7.0 (Safe Working Practices); updated Ch. IV, §1.3.2.2 (MARPOL Annex IV); updated Ch. IV, §1.3.3.3 (MARPOL Annex V); updated Ch. IV, §1.5 (BWM Convention); minor edit to Ch. IV, §4.13.3 (Bulwarks and Guard Rails); edits to Ch. IV, §6.2.1 (Fire Control Plans); updated Ch. IV §6.3.10, (Ventilation); updated Ch. IV, §6.4.3 (Means of Escape); updated Ch. IV, §7.3.1 (Steering Systems); added Ch. IV, §7.5.4.5 (Batteries); minor edit to Ch. IV, §13.0 (Publications), Table 23; updated title of Ch. IV,	M. Sparks	04/01/17

		§19.0 (Safe Working Practices); minor edit to Ch. V, §2.0 (Marine Guidelines); updated Annex 1, §10.0 (Compliance Verification, Review, and Evaluation); updated Annex 4, §2.3 & §2.4; & updated the TOC to reflect above changes.		
2014/2015 Series Rev. 2	10/15	Updated extensively throughout and completely re-formatted; renumbered and minor edits incorporated; note particularly revised §§ 17.2.4 (Rescue Boats) & 11.1.5 (Table 8) in Ch. III & new Ch. V on Yachts Engaged in Trade; & updated the TOC to reflect above changes.	M. Sparks	10/30/15
2014/2015 Series Rev. 1	02/14	Updated all sections to reflect that the Code applies to all commercial yachts registered in the RMI; added new §16.2.6 on additional fire appliances; removed references to semi-annual in §32.0; updated table and footnotes in Annex 1; TOC updated to reflect above changes	M. McConnell	02/19/14
2012 Series Rev. 4	12/13	Updated table and footnotes in Annex 1	M. McConnell	12/02/13
2012 Series Rev. 3	11/13	Removed references to Authorized Surveyor and Yacht Nautical Inspector; added references to passenger yachts throughout; added new item 17.3; updated §32.0; updated table in Annex 1	M. McConnell	11/01/13
2012 Series Rev. 2	06/13	Extensively revised in all sections and section on MLC, 2006 added; TOC updated to reflect above changes	M. McConnell	06/17/13
2009 Series Rev. 1	12/09	Revised the definition of “Private Yacht” (page 9); updated form MI-105M in Annex 9 (pages 108-109); updated Medical Chest in Annex 10 (pages 110-126); updated header in form MI-127 in Annex 12 (page 128); updated TOC to reflect repagination.	M. McConnell	12/10/09
2009 Series	11/08	Annex 4: numbered paragraphs and replaced previous 7 th paragraph with new paragraphs 1.7 & 1.8 (page 99); corrected deck ratings and engine personnel requirements in Category 2 in table on page 100 & deleted previous page 101 containing table on MI Yacht Certificates of Competency; updated TOC to reflect repagination.	M. McConnell	11/11/08
-	10/08	Original	M. McConnell	10/15/08